

FLOOR PLAN

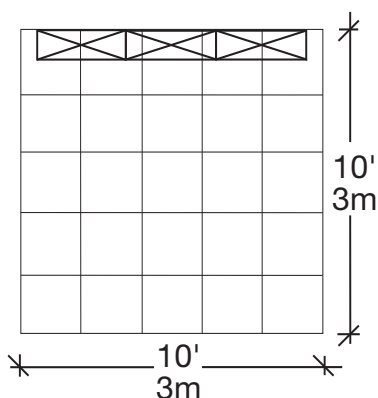

ELEVATION

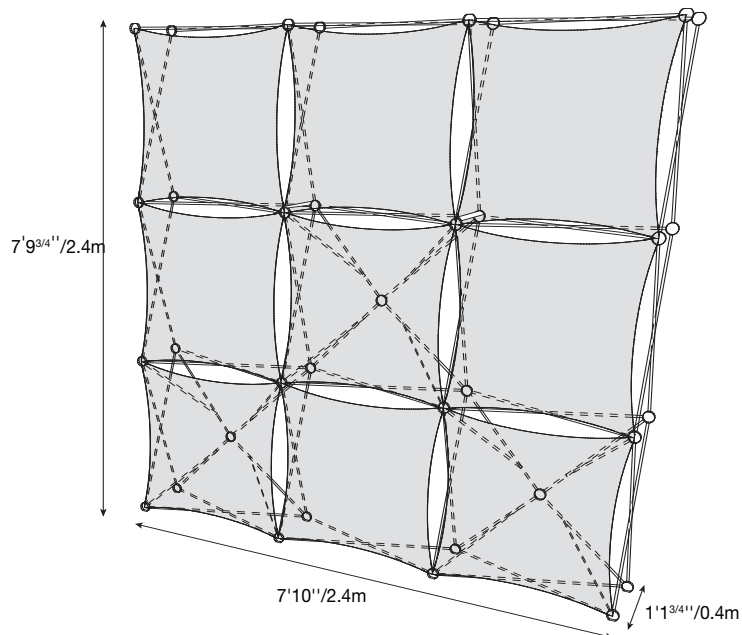

Code	Qty.	Description	Total Lbs.	Unit Price \$	Total Price \$
PX33M	1	3x3 XPlus Frame with Manual Lock	10.50	1137	1137
SB33	1	Carry Bag	4.80	125	125
PXK33BG	1	XQusite in a Carry Bag	15.30		1262
PX33M	1	3x3 XPlus Frame with Manual Lock	10.50	1137	1137
CRL	1	Rolluxe	25.00	350	350
PXK33RL	1	XQusite in a Rolluxe Case	35.50		1487

Suggested Accessories (Extra cases will be required)

PXKHALUS2	1	Set of 2 XPlus Halogen Lights and ElectroStrut in a Tuxedo Box	4.90	407	407
PXKSHF	1	XPlus Shelf Kit	4.00	133	133
SPPPTD	1	Plus Pass Through Top Panel with 2 Halogen Downlights	3.10	282	282

***Note: Accessories will not fit in a carry bag.**
Shelf max weight is 20lbs/9.07Kg.
See style sheet for possible configurations.



PX33M_A

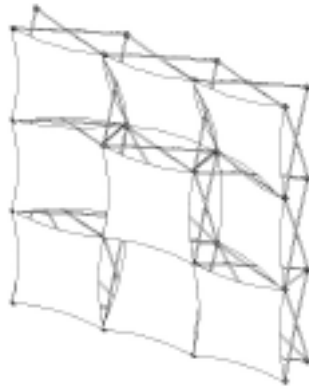

PX33M_B

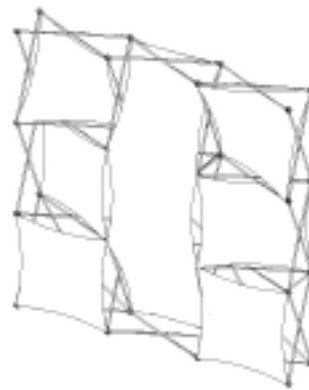

PX33M_C

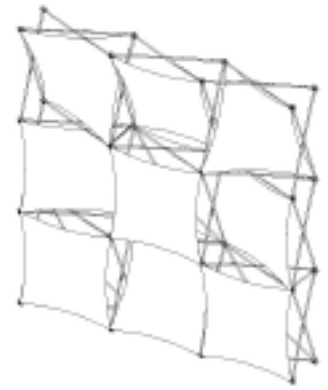

PX33M_D



PX33M_E

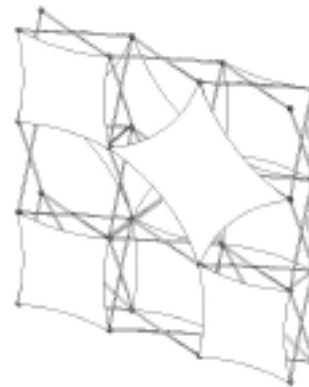

PX33M_F

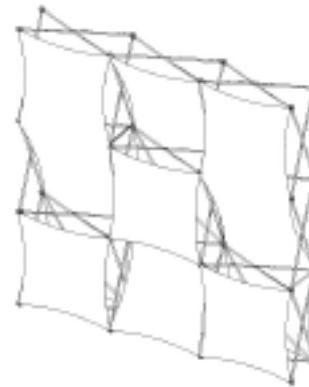

PX33M_G



PX33M_H



PX33M_I

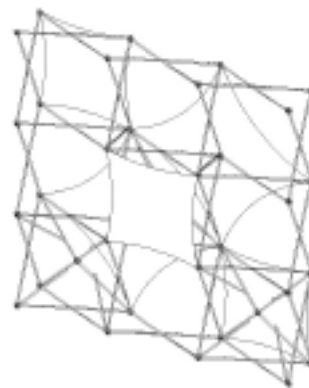

PX33M_J

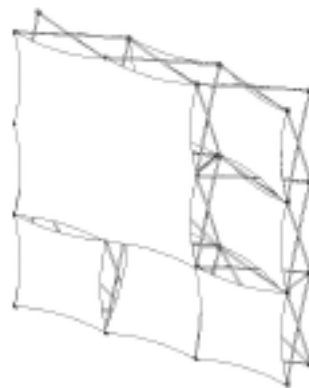

PX33M_K

Note: For graphic sizes please see individual style sheets.