

# Table of Contents

- 1** Quick Reference Guide
- 2** Instand<sup>®</sup> Classic
- 3** Instand<sup>®</sup> Plus
- 4** Instand<sup>®</sup> Enhancements
- 5** Traveler<sup>™</sup>
- 6** Ideal<sup>™</sup>
- 7** FabriMural<sup>™</sup>
- 8** XPlus<sup>™</sup>
- 9** Platinum<sup>®</sup>
- 10** DesignLine<sup>®</sup>
- 11** Banner Stands
- 12** ImageMaker<sup>®</sup>
- 13** Counters
- 14** Stiffeners/Graphic Production Materials
- 15** Glossary of Digital Printing

## File Formats We Accept



Adobe  
PhotoShop CS3



Adobe  
Illustrator CS3



Adobe  
InDesign CS3



Quark  
XPress 7

## Vector Art Guidelines

### We are currently operating in Illustrator CS3

#### General Layout

Your file should contain only live print elements. Do not include extraneous boxes, etc. that are not supposed to print.

#### Images

DO NOT EMBED LINKED IMAGES. This makes files extremely large and difficult to edit. Linked images should be included at 100 DPI at full size (100% scale). Images should be flattened TIFFs.

#### Transparencies, Drop Shadows and Special Effects

We highly recommend that drop shadows, transparencies, elaborate effects, etc. be created in Photoshop and placed into the Illustrator document. Although Illustrator allows creation of these effects, they print very erratically. If you must create these images in Illustrator, you must then rasterize them in Photoshop and replace them in the original document to guarantee successful printing.

#### Text

In case of text changes, please supply all fonts used in the production of your graphic. This will save time in the approval and production process.

#### Saving your image

Save your illustrator file as a .eps file.

#### Color

If color matching is required, please call out PMS equivalents in file and on P.O. This will ensure that we can match them accordingly. If there exists any other collateral that you wish to match, please provide with order.

#### Multiple Panels

If you are creating a multiple panel image, please build the image as one file. Feel free to add guides on the page to indicate panels breaks.

#### Bleed

Please provide 1" bleed in order to properly size your graphic. Large format graphics are always produced larger than finished size in order to accommodate material issues. If text and or images are placed too close to the edges, we cannot guarantee that they won't be cropped off.

#### Furnish hard copy proofs or PDF's with your art

By including documentation along with order and art, we can match layout and even identify certain file issues at the pre-flight stage.

## Raster Art and Vector Art

---

### Vector Art

A shape or object made up of a group of closed lines and curves to create the image. Vector or line art is used to create shapes and images that are not photo realistic. Through the use of gradients and fills this type of art can be used to create colorful images that if constructed correctly can be produced at any size without resolution issues. Vector art can be produced in Illustrator, InDesign, Freehand and Quark.

### Raster Art

Images made up of pixels or picture elements. They have the ability if constructed correctly to produce a photo realistic image of very high quality. The quality of the image is dependent upon how many pixels are built into the original file. The minimum DPI (dots per inch) or PPI (pixels per inch) is 100 when the graphic is at 100% (full sized). Raster art is produced in Photoshop.

## Tips and Tricks

### Outline Fonts

Fonts in vector art must be converted to paths. To achieve this, select your fonts and then go to the type pull down menu. Select the option that says create outlines. This will ensure that the fonts will print properly. If type changes are to be accomplished, you must provide the required fonts in order to keep size, weight and kerning consistent.

### Provide Bleeds

Please provide sufficient bleed in order to properly size your graphic. Large format graphics are always produced larger than finished size in order to accommodate material issues. If text and or images are placed to close to the edges, we cannot guarantee that they won't be cropped off.

### Furnish hard copy proofs or PDF's with your art

By including documentation along with order and art, we can match colors, layout and even identify certain file issues at the pre-flight stage.

As always, if you have issues or questions while building your art files, please contact the Nomadic graphics department at 800 336-5019 and we will be happy to assist you in any way we can.

## Suggestions for Setting Up Your Graphic Document

### Step 1 - Set Document Size

Assign the document's dimension according to the specifications on the following pages. Include bleed when setting the document size. Be precise. Do not round the sizes.

### Step 2 - Add Guides

First, make the upper left corner of the document the zero point by pulling the crosshairs to that corner of the document. The crosshairs can usually be found where the vertical and horizontal rulers meet. Next, pull the guides to the trim areas and panel breaks. Again, please be precise and place the guides as close as possible to the required measurements (zoom in as far as necessary). You are to build the multiple-panel mural as one piece. We will panel the file when it's printed.

### Step 3 - Import/Create Artwork

Bring your artwork into the document. Keep in mind your booth configuration when designing your graphics. Knowing the sightlines and panel breaks will help you place your information so that it is displayed effectively and conveys your message.

### Step 4 - Pull Bleed

Extend the edges of the artwork into the bleed areas so that when these are trimmed off, your graphic will have a full-bleed look with no borders at the edges.

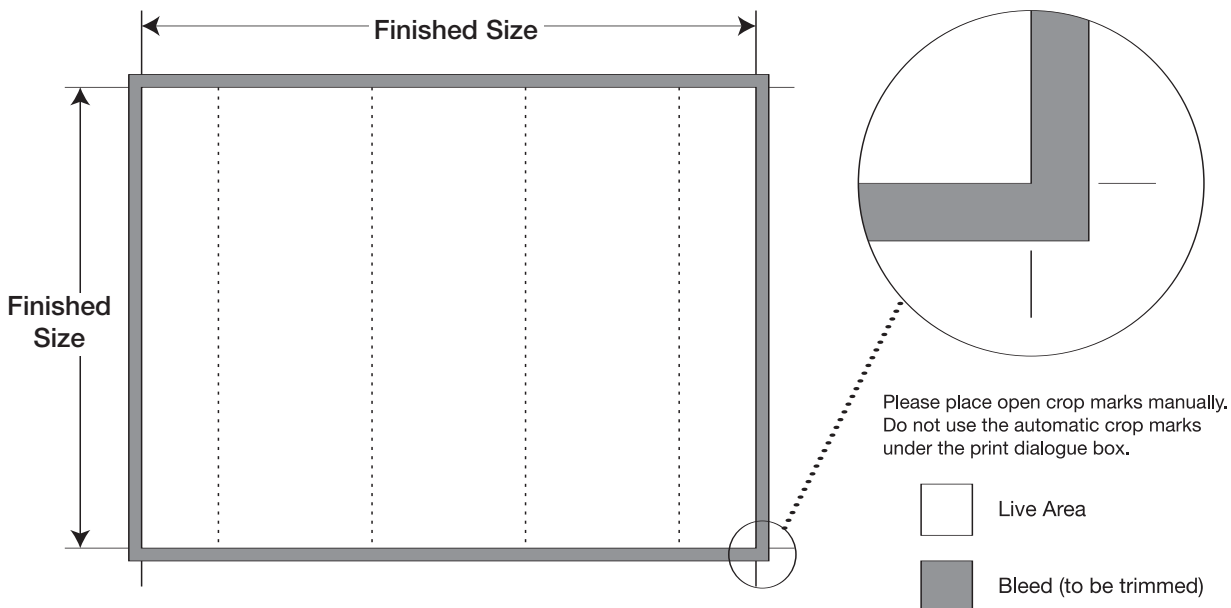

Add bleeds to give finishers/mounters a clean edge to trim.  
 "Bleed" is extended background image, additional to the final graphic size, that will be trimmed away.  
 Open crop marks indicate where finisher should trim. For murals, crop marks need to be added for panel breaks as well as the outside edges.

Mural Panels: Add 1" minimum to each side (left/right/top/bottom)  
 Detachable: Add 1/2" to each side (left/right/top/bottom)  
 Headers: Add 1/2" to each side (left/right/top/bottom)  
 Headliners: Add 1/2" to each side (left/right/top/bottom)

You have two options to upload graphics to Nomadic's FTP server. Both of these options use the same host name, user id and password.

### Login Information

Host: nomadic.ftpstream.com

Your user id and password are the same ones used to access the Nomadic Distributor Info Website.

### Uploading artwork via an FTP Program



1. Open FTP Software
2. Type in Host: nomadic.ftpstream.com
3. Type in User ID: This is the same as your distributor website User ID.
4. Type in Password: This is the same as your distributor website password
5. Upload artwork

### Uploading artwork via Windows Explorer

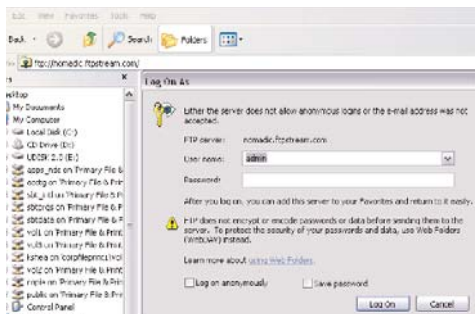

1. Right Click on "Start"
2. Click on "Explore"
3. Type in Address Bar: ftp://nomadic.ftpstream.com
4. Type in User Id: This is the same as your distributor website User ID.
5. Type in Password: This is the same as your distributor website password
6. Copy over artwork

### Helpful Tips

1. For faster uploading it would be best if you "stuffed" or "zipped" your artwork before uploading. These include .zip, .sit, .sitx. Please make sure your folder name is all one word by using "\_" Example: client\_name\_artwork.zip
2. Do not delete any files from your folder on our ftp server. This could cause miscommunication.
3. Make sure you upload the "Graphic Order Form" in side your artwork folder. You can download a blank form from your folder.
4. Contact graphics@nomadicdisplay.com for any technical issues.

## Classic System Standard Sizes

### Classic Front (concave) Panels

| HxW                        | W                   | I          | D          | T          | H          |            |            |
|----------------------------|---------------------|------------|------------|------------|------------|------------|------------|
| H<br>E<br>I<br>G<br>H<br>T | <b>Front Panels</b> | 29.4375"   | 58.875"    | 88.3125"   | 117.75"    | 147.1875"  | 176.625"   |
|                            | 28.1875"            | <b>C11</b> | <b>C12</b> | <b>C13</b> | <b>C14</b> | <b>C15</b> | <b>C16</b> |
|                            | 59"                 | <b>C21</b> | <b>C22</b> | <b>C23</b> | <b>C24</b> | <b>C25</b> | <b>C26</b> |
|                            | 89.75"              | <b>C31</b> | <b>C32</b> | <b>C33</b> | <b>C34</b> | <b>C35</b> | <b>C36</b> |
|                            | 120.5"              | <b>C41</b> | <b>C42</b> | <b>C43</b> | <b>C44</b> | <b>C45</b> | <b>C46</b> |
|                            | 151.25"             | <b>C51</b> | <b>C52</b> | <b>C53</b> | <b>C54</b> | <b>C55</b> | <b>C56</b> |
|                            | 182"                | <b>C61</b> | <b>C62</b> | <b>C63</b> | <b>C64</b> | <b>C65</b> | <b>C66</b> |

Note: Bolded area indicated most popular sizes

|                |                      |  |
|----------------|----------------------|--|
| Classic System | Small Round Endcaps: | 15" wide by <i>panel height</i>                          |
|                | Small Flat Endcaps:  | 9.15625" wide by <i>panel height</i>                     |
|                | Dual Endcaps:        | 29.4375" wide by <i>panel height</i>                     |
|                | Trapezoid Endcaps:   | 15"(top) x 29.40625"(bottom) wide by <i>panel height</i> |
|                | Large Round Endcaps: | 29.4375" wide by <i>panel height</i>                     |

### Classic Back (convex) Panels

| HxW                        | W                  | I          | D          | T          | H          |            |            |
|----------------------------|--------------------|------------|------------|------------|------------|------------|------------|
| H<br>E<br>I<br>G<br>H<br>T | <b>Back Panels</b> | 32.5"      | 65"        | 97.5"      | 130"       | 162.5"     | 195"       |
|                            | 28.1875"           | <b>C11</b> | <b>C12</b> | <b>C13</b> | <b>C14</b> | <b>C15</b> | <b>C16</b> |
|                            | 59"                | <b>C21</b> | <b>C22</b> | <b>C23</b> | <b>C24</b> | <b>C25</b> | <b>C26</b> |
|                            | 89.75"             | <b>C31</b> | <b>C32</b> | <b>C33</b> | <b>C34</b> | <b>C35</b> | <b>C36</b> |
|                            | 120.5"             | <b>C41</b> | <b>C42</b> | <b>C43</b> | <b>C44</b> | <b>C45</b> | <b>C46</b> |
|                            | 151.25"            | <b>C51</b> | <b>C52</b> | <b>C53</b> | <b>C54</b> | <b>C55</b> | <b>C56</b> |
|                            | 182"               | <b>C61</b> | <b>C62</b> | <b>C63</b> | <b>C64</b> | <b>C65</b> | <b>C66</b> |

Note: Bolded area indicated most popular sizes

## Classic System Standard Sizes

### Classic Wrap Headers

| HxW    | WIDTH               |                |            |            |
|--------|---------------------|----------------|------------|------------|
| HEIGHT | <b>Wrap Headers</b> | 88.875"        | 119.25"    | 148.5"     |
|        | 8"-10" *            | <b>C12,C22</b> | <b>C23</b> |            |
|        | 12"-15" *           |                | <b>C33</b> | <b>C34</b> |

\* Headers can be any height. We recommend the indicated heights for visually pleasing proportions.

Wrap Header **15" VOID SPACE**  
on each end of wrap header  
Do not place text/logo in void space

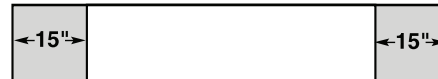

### Classic Non-Wrap Headers

| HxW    | WIDTH                   |            |            |            |
|--------|-------------------------|------------|------------|------------|
| HEIGHT | <b>Non-Wrap Headers</b> | 58.875"    | 83.3125"   | 117.75"    |
|        | 7"                      | <b>C12</b> |            |            |
|        | 8"-12"                  | <b>C22</b> | <b>C23</b> |            |
|        | 12"-15"                 |            | <b>C33</b> | <b>C34</b> |

\* Headers can be any height. We recommend the indicated heights for visually pleasing proportions.

### Classic Backlit Headliners

| HxW    | WIDTH                     |            |                |            |
|--------|---------------------------|------------|----------------|------------|
| HEIGHT | <b>Backlit Headliners</b> | 62.75"     | 83.5"          | 106.375"   |
|        | 14.562"                   | <b>C22</b> | <b>C23,C33</b> | <b>C34</b> |

Headliner **LIVE AREA** (12.5" x 50.75" or 71.5" or 94.375")  
The live area is the only area where text/logo can be placed  
The live area is centered on panel

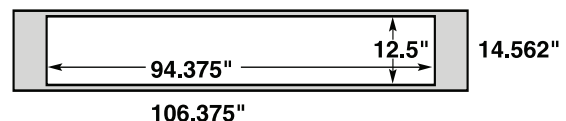
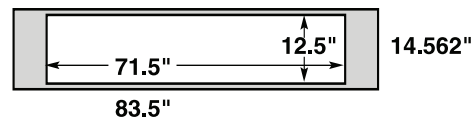
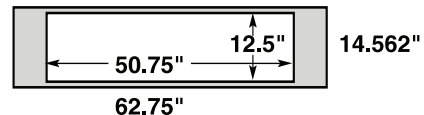

## Plus System Standard Sizes

### Plus Panels

| HxW                        | W I D T H     |            |            |            |            |
|----------------------------|---------------|------------|------------|------------|------------|
| H<br>E<br>I<br>G<br>H<br>T | <b>Panels</b> | 30.6875"   | 61.375"    | 92.0625"   | 122.75"    |
|                            | 28.1875"      | <b>P11</b> | <b>P12</b> | <b>P13</b> | <b>P14</b> |
|                            | 59"           | <b>P21</b> | <b>P22</b> | <b>P23</b> | <b>P24</b> |
|                            | 89.75"        | <b>P31</b> | <b>P32</b> | <b>P33</b> | <b>P34</b> |
|                            | 120.5"        | <b>P41</b> | <b>P42</b> | <b>P43</b> | <b>P44</b> |
|                            | 151.25"       | <b>P51</b> | <b>P52</b> | <b>P53</b> | <b>P54</b> |
|                            | 182"          | <b>P61</b> | <b>P62</b> | <b>P63</b> | <b>P64</b> |

Note: Bolded area indicated most popular sizes

Plus System

|  |   |
|--|---|
| Large Round Endcaps:                                 | 30.6875" wide by <i>panel</i> height        |
| Trapezoid Endcaps: 15"(top) x 29.40625"(bottom) wide | by <i>panel</i> height                      |
| Large Flat Endcaps:                                  | 15.71875" wide by <i>panel</i> height       |
| Extended Endcaps:                                    | <i>normal panel</i> width by 29.125" height |
| P11E Extended Quad:                                  | 30.6875" wide by 29.125" height             |

### Plus Wrap Headers

| HxW                        | W I D T H           |            |            |
|----------------------------|---------------------|------------|------------|
| H<br>E<br>I<br>G<br>H<br>T | <b>Wrap Headers</b> | 122.75"    | 153.4375"  |
|                            | 15"                 | <b>P32</b> | <b>P33</b> |

Wrap Header **30.6875" VOID SPACE**  
 on each end of wrap header  
 Do not place text/logo in void space

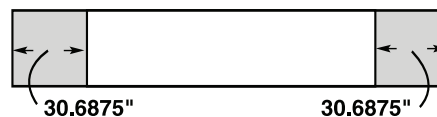

### Plus Non-Wrap Headers

| HxW                        | W I D T H               |            |            |
|----------------------------|-------------------------|------------|------------|
| H<br>E<br>I<br>G<br>H<br>T | <b>Non-Wrap Headers</b> | 61.375"    | 92.0625"   |
|                            | 15"                     | <b>P32</b> | <b>P33</b> |



## Nomadic Display System Standard Sizes

### Classic Panels Others

|   |                |    |                  |
|---|----------------|----|------------------|
| One and a quarter (1 1/4) quad:               | 29.4375" wide  | by | 38.25" height    |
| One and a quarter (1 1/4) Small Round Endcap: | 15" wide       | by | 38.25" height    |
| Two Quad Reduced:                             | 23.21875" wide | by | 46.34375" height |
| Two Quad Reduced Small Round Endcap:          | 12" wide       | by | 46.34375" height |
| Three Quad Reduced:                           | 23.21875" wide | by | 70.75" height    |
| Three Quad Reduced Small Round Endcap:        | 12" wide       | by | 70.75" height    |

### Plus Panels Others

|  |               |    |               |
|--|---------------|----|---------------|
| Three Quad Small Quarter Round Endcap:           | 19.5" wide    | by | 89.75" height |
| Three Quad Medium Quarter Round Endcap:          | 22.5" wide    | by | 89.75" height |
| Three Quad Large Quarter Round Endcap:           | 25" wide      | by | 89.75" height |
| Three Quad Large Connecting Panel with 1" hinge: | 30.6875" wide | by | 89.75" height |

Connecting Panel with hinge void space:  
Leave **1.5" VOID SPACE** on **left and right sides** of Connecting Panel  
Do not place text/logo in void space

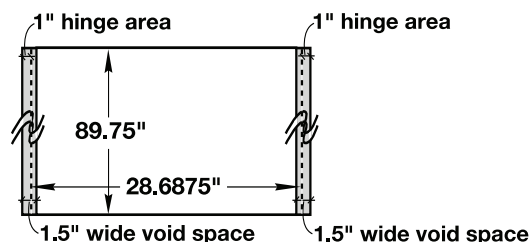

### Filler Strips:

|                     |             |    |              |
|---------------------|-------------|----|--------------|
| Instand to Instand  | 1.875" wide | by | panel height |
| Instand to Platinum | 1.75" wide  | by | panel height |

### Rolluxe Counter Detachable

|                          |            |    |            |
|--------------------------|------------|----|------------|
| Detachable maximum size: | 25.5" wide | by | 39" height |
|--------------------------|------------|----|------------|

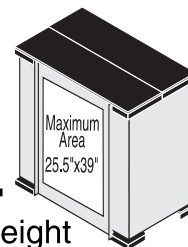

## Nomadic Display System Standard Sizes

### Banner Stands

|                 |            |    |               |
|-----------------|------------|----|---------------|
| SignLine Swift: | 31.4" wide | by | 57.87" height |
|-----------------|------------|----|---------------|

|                 |            |    |               |
|-----------------|------------|----|---------------|
| SignLine Swift: | 31.4" wide | by | 82.67" height |
|-----------------|------------|----|---------------|

Banner Stand void space:  
There is **3.93" VOID SPACE** on bottom of SignLine Swift  
Do not place text/logo in void space

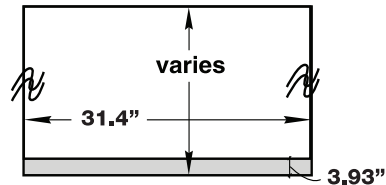

|                   |            |    |            |
|-------------------|------------|----|------------|
| SignLine Express: | 31.5" wide | by | 85" height |
|-------------------|------------|----|------------|

Banner Stand void space:  
There is **2.3125" VOID SPACE** on bottom of SignLine Swift  
Do not place text/logo in void space

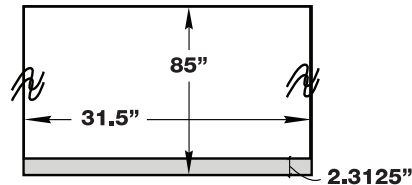

|                    |            |    |            |
|--------------------|------------|----|------------|
| SignLine Standard: | 31.5" wide | by | 60" height |
|--------------------|------------|----|------------|

|                    |            |    |            |
|--------------------|------------|----|------------|
| SignLine Standard: | 31.5" wide | by | 84" height |
|--------------------|------------|----|------------|

|                    |             |    |            |
|--------------------|-------------|----|------------|
| SignLine Standard: | 34.75" wide | by | 60" height |
|--------------------|-------------|----|------------|

|                    |             |    |            |
|--------------------|-------------|----|------------|
| SignLine Standard: | 34.75" wide | by | 84" height |
|--------------------|-------------|----|------------|

|                    |            |    |            |
|--------------------|------------|----|------------|
| SignLine Standard: | 39.5" wide | by | 60" height |
|--------------------|------------|----|------------|

|                    |            |    |            |
|--------------------|------------|----|------------|
| SignLine Standard: | 39.5" wide | by | 84" height |
|--------------------|------------|----|------------|

Banner Stand void space:  
There is **2.3125" VOID SPACE**  
**on top and bottom** of SignLine Swift  
Do not place text/logo in void space

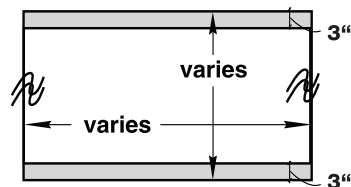

## Nomadic Display System Standard Sizes

### Power Panels

|                          |               |    |                     |
|--------------------------|---------------|----|---------------------|
| Classic or Plus Frame:   | 34" wide      | by | <i>panel</i> height |
| Classic Reflector Panel: | 29.4375" wide | by | <i>panel</i> height |
| Plus Reflector Panel:    | 30.6875" wide | by | <i>panel</i> height |

Power Panel void space:  
 There is **2" VOID SPACE** on **left and right sides** of Power Panel  
 There is **1" VOID SPACE** on **top and bottom sides** of Power Panel  
 Do not place text/logo in void space

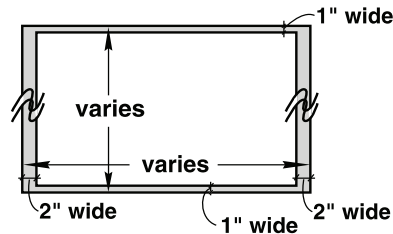

### Bridges

|                              |              |    |                 |
|------------------------------|--------------|----|-----------------|
| 63" Bridge Trim Size:        | 62.875" wide | by | 14.562" height  |
| 63" Triangular Filler Panel: | 63" wide     | by | 1.625" height   |
| 63" Square Diffuser Panel:   | 63" wide     | by | 12.6785" height |

Bridge **LIVE AREA**  
 center live area on panel

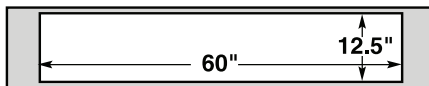

|                              |              |    |                 |
|------------------------------|--------------|----|-----------------|
| 94" Bridge Trim Size:        | 93.5" wide   | by | 14.562" height  |
| 94" Triangular Filler Panel: | 93.625" wide | by | 1.625" height   |
| 94" Square Diffuser Panel:   | 93.625" wide | by | 12.6785" height |

Bridge **LIVE AREA**  
 center live area on panel

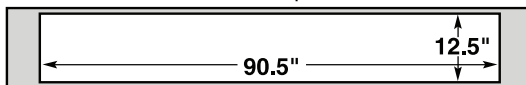

## Capella Kit

## Classic Configuration

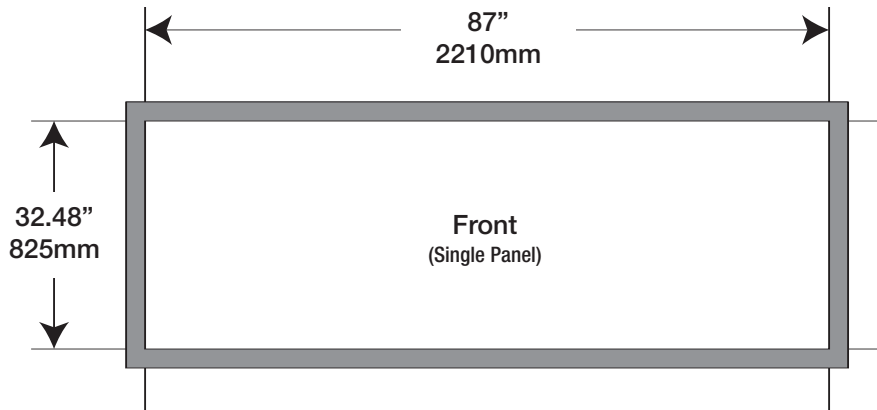

### Minimum Document Size\*

(with Bleed)

Width: 89" x Height: 34.48"  
2261mm x 767mm

(50% with Bleed)

Width: 44.5" x Height: 17.24"  
1131mm x 383.5mm

(25% with Bleed)

Width: 22.25" x Height: 8.62"  
566mm x 191.75mm

### Finished Size

Width: 87" x Height: 32.4"  
2210mm x 716mm

\*Your document size should encompass the crops and bleed area.

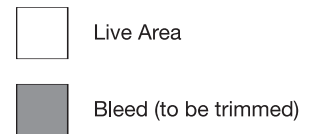

### FLOOR PLAN

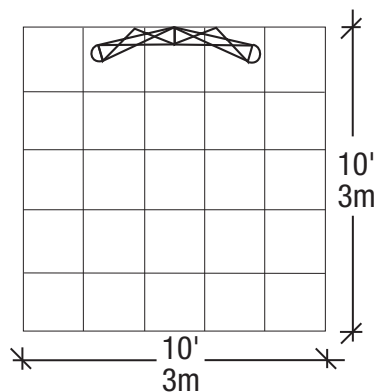

### ELEVATION

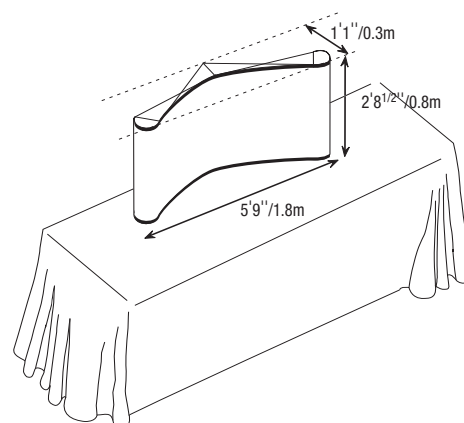

## Mars Kit

## Classic Configuration

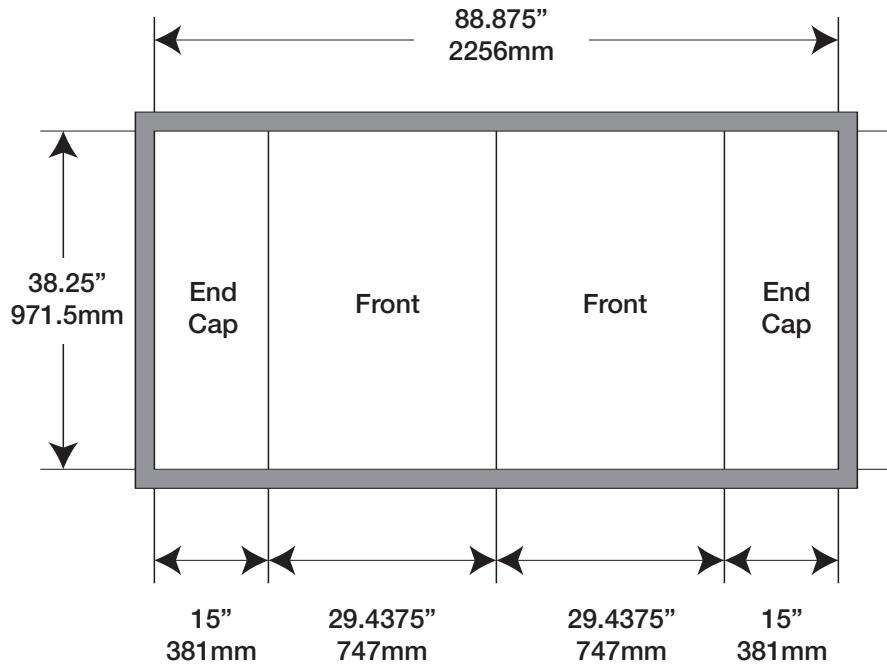

### Minimum Document Size\*

(with Bleed)

Width: 90.875" x Height: 40.25"  
2307mm x 1022.5mm

(50% with Bleed)

Width: 45.4375" x Height: 20.125"  
1154mm x 511.25mm

(25% with Bleed)

Width: 22.71875" x Height: 10.0625"  
577mm x 255.625mm

### Finished Size

Width: 88.875" x Height: 38.25"  
2256mm x 971.5mm

\*Your document size should encompass the crops and bleed area.

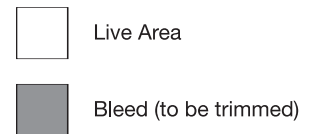

### FLOOR PLAN

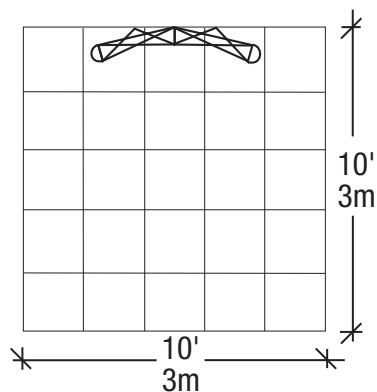

### ELEVATION

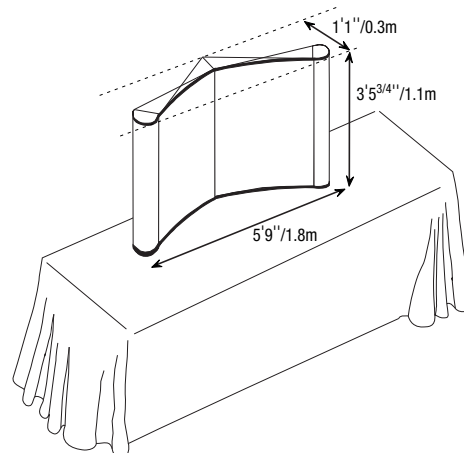

## Sirius Kit

## Classic Configuration

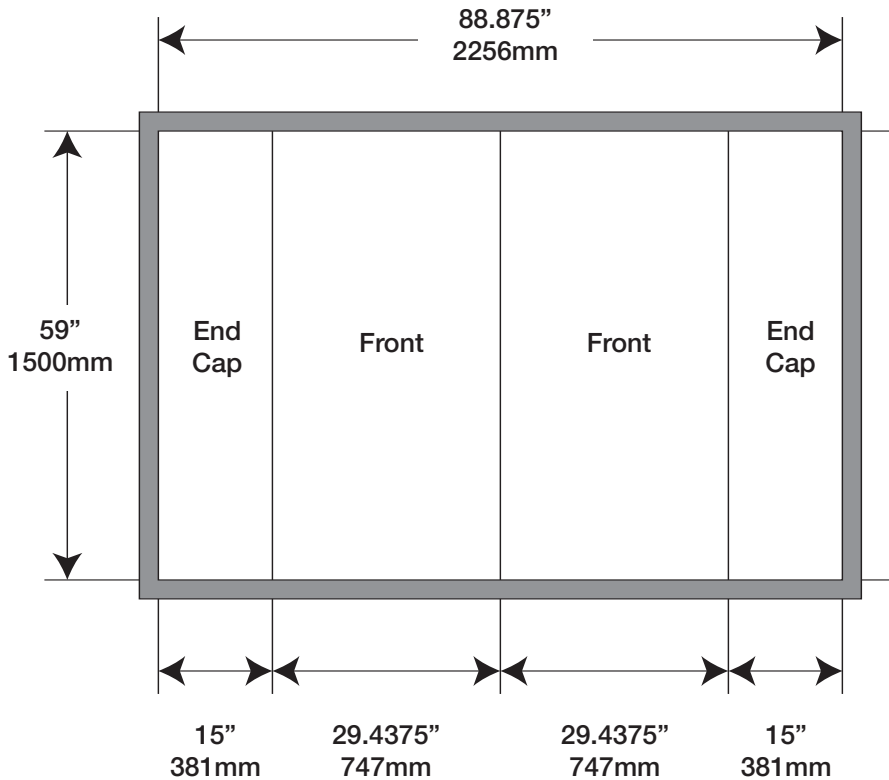

### Minimum Document Size\*

(with Bleed)

Width: 90.875" x Height: 61"  
2307mm x 1551mm

(50% with Bleed)

Width: 45.4375" x Height: 30.5"  
1154mm x 776mm

(25% with Bleed)

Width: 22.71875" x Height: 15.25"  
577mm x 388mm

### Finished Size

Width: 88.875" x Height: 59"  
2256mm x 1500mm

\*Your document size should encompass the crops and bleed area.

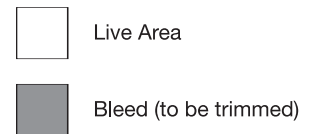

**FLOOR PLAN**

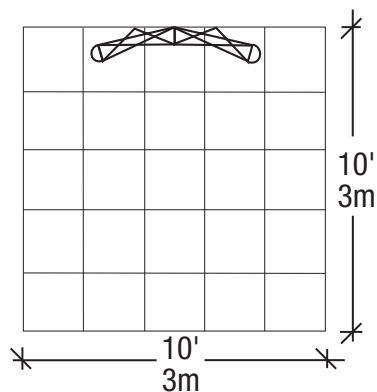

**ELEVATION**

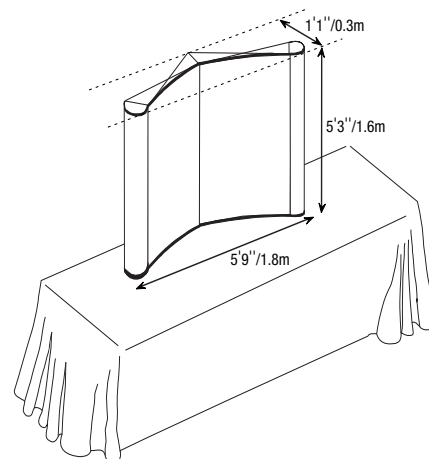

## Venus Kit

## Classic Configuration

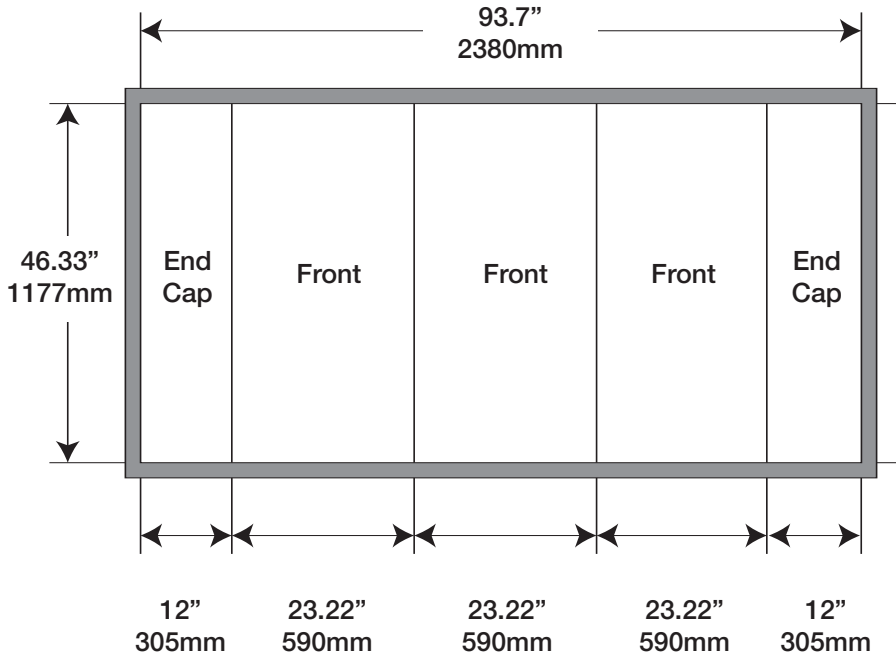

### Minimum Document Size\*

(with Bleed)

Width: 120.3125" x Height: 48.33"  
2431mm x 1228mm

(50% with Bleed)

Width: 60.15625" x Height: 24.165"  
1215.5mm x 614mm

(25% with Bleed)

Width: 30.078125" x Height: 12.0825"  
607.75mm x 307mm

### Finished Size

Width: 118.3125" x Height: 46.33"  
2380mm x 1177mm

\*Your document size should encompass the crops and bleed area.

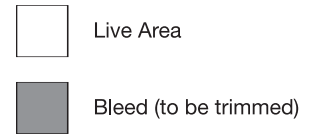

**FLOOR PLAN**

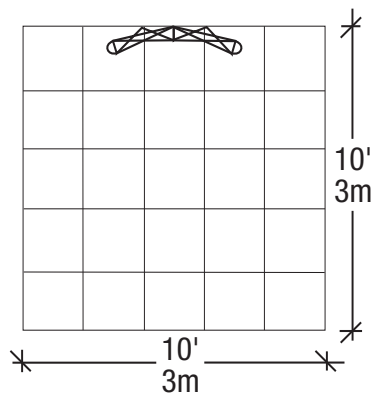

**ELEVATION**

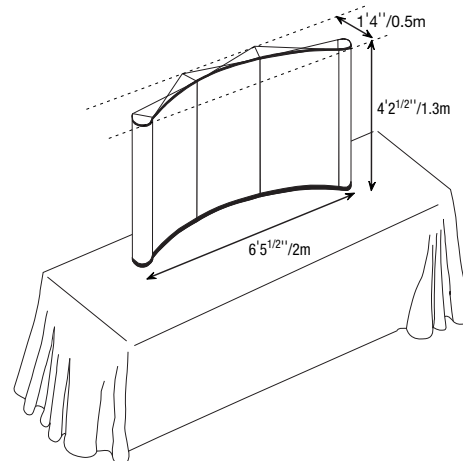

## Libra Kit

## Classic Configuration

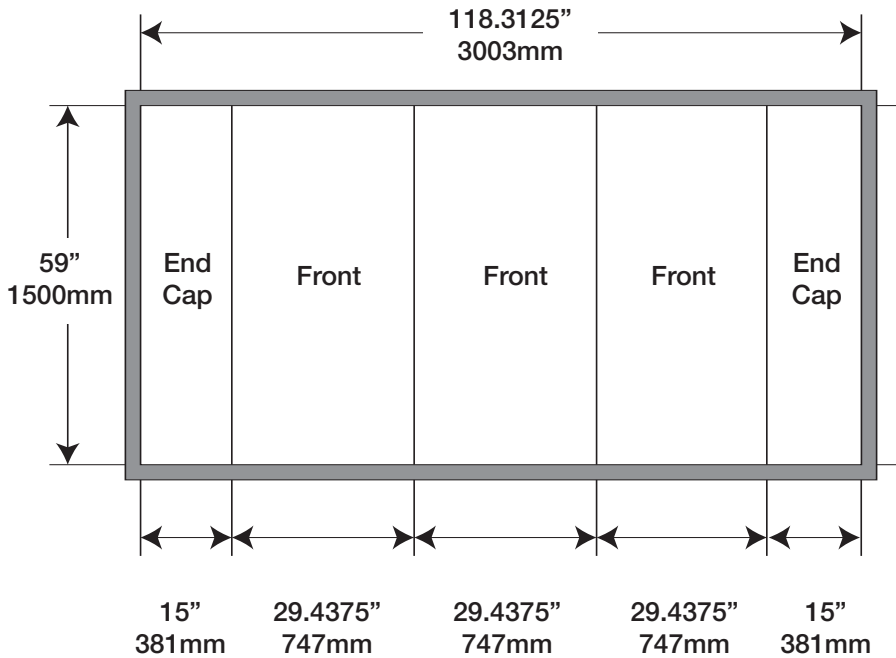

### Minimum Document Size\*

(with Bleed)

Width: 120.3125" x Height: 61"  
3054mm x 1551mm

(50% with Bleed)

Width: 60.15625" x Height: 30.5"  
1527mm x 776mm

(25% with Bleed)

Width: 30.078125" x Height: 15.25"  
764mm x 388mm

### Finished Size

Width: 118.3125" x Height: 59"  
3003mm x 1500mm

\*Your document size should encompass the crops and bleed area.

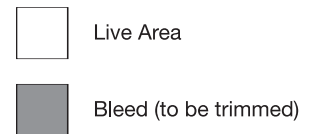

### FLOOR PLAN

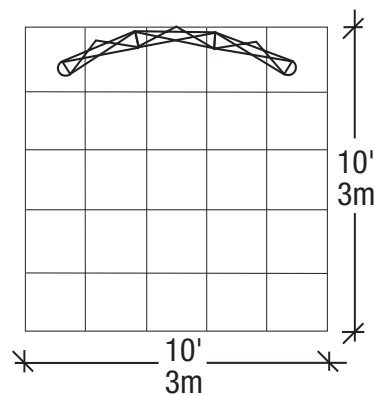

### ELEVATION

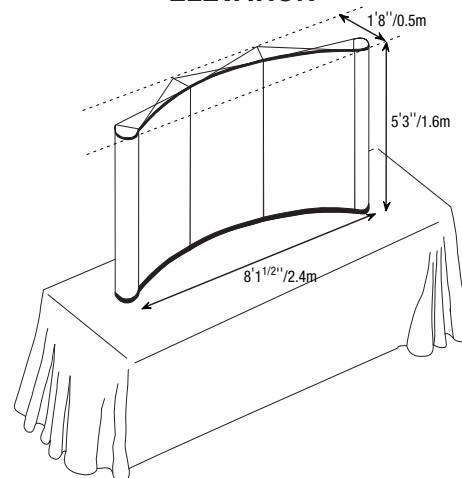



## Sagittarius Kit

## Classic Configuration

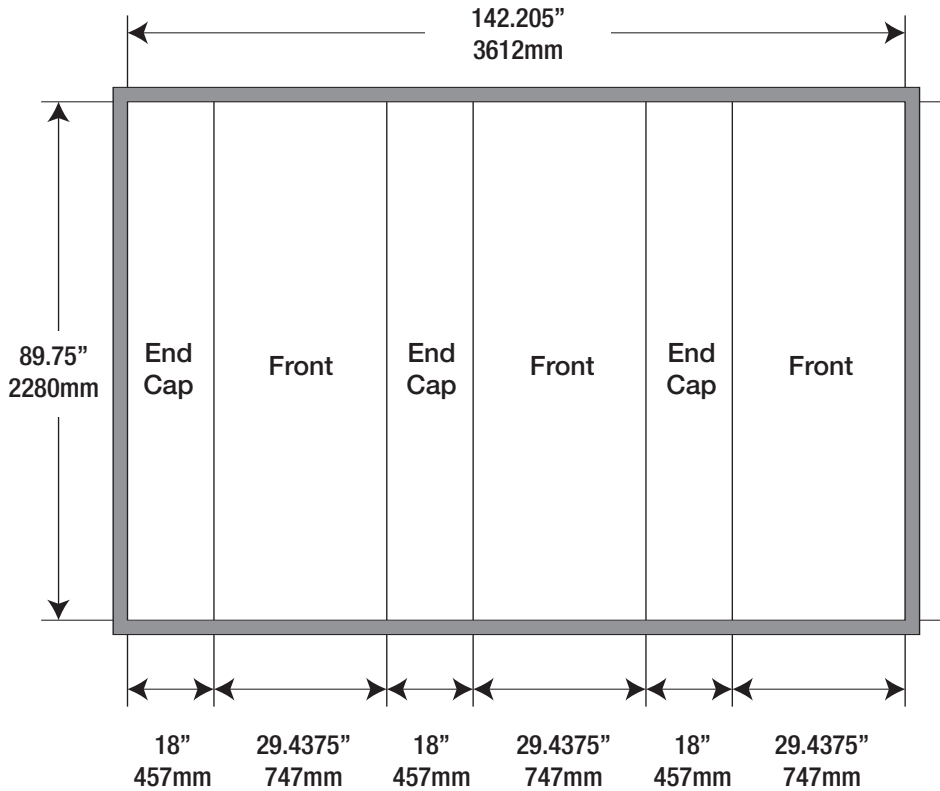

### Minimum Document Size\*

(with Bleed)

Width: 144.205" x Height: 91.75"  
3663mm x 2331mm

(50% with Bleed)

Width: 72.1025" x Height: 45.875"  
1831.5mm x 1166mm

(25% with Bleed)

Width: 36.05125" x Height: 22.9375"  
915.75mm x 583mm

### Finished Size

Width: 142.205" x Height: 89.75"  
3612mm x 2280mm

\*Your document size should encompass the crops and bleed area.

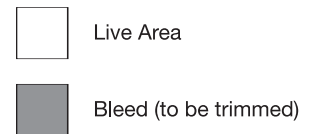

### FLOOR PLAN

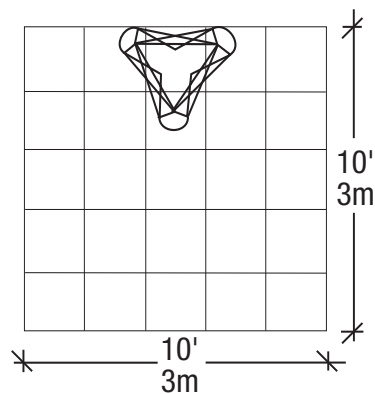

### ELEVATION

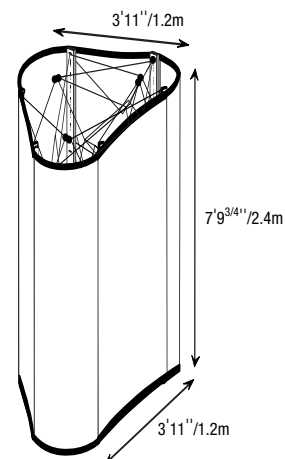

## Capricorn Kit

## Classic Configuration

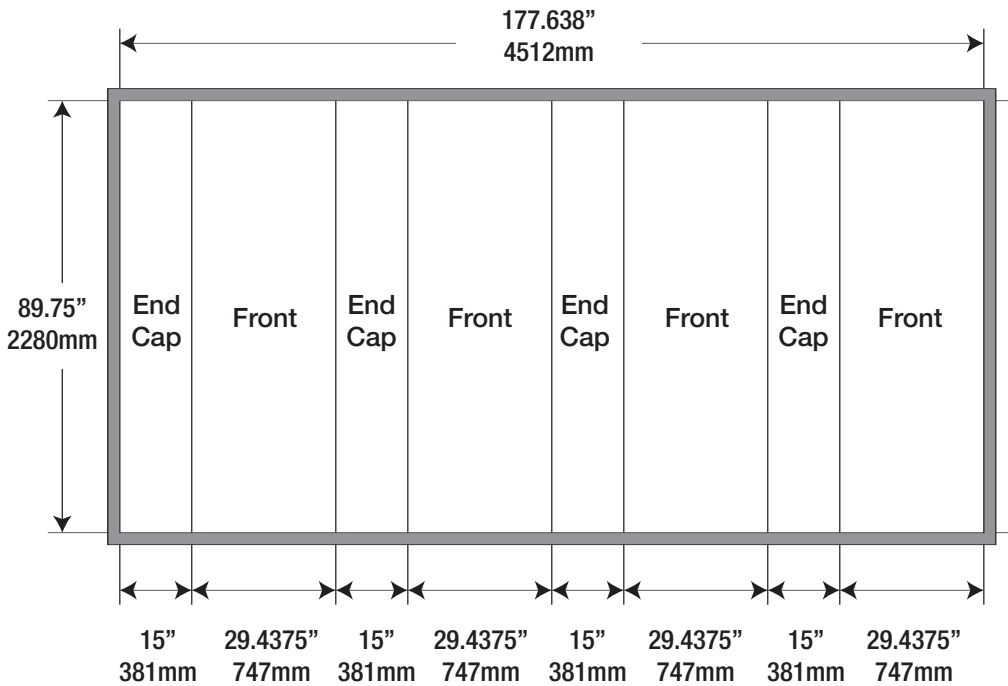

### Minimum Document Size\*

(with Bleed)

Width: 179.638" x Height: 91.75"  
4563mm x 2331mm

(50% with Bleed)

Width: 89.819" x Height: 45.875"  
2281.5mm x 1166mm

(25% with Bleed)

Width: 44.91" x Height: 22.9375"  
1140.75mm x 583mm

### Finished Size

Width: 177.638" x Height: 89.75"  
4512mm x 2280mm

\*Your document size should encompass the crops and bleed area.



Live Area



Bleed (to be trimmed)

**FLOOR PLAN**

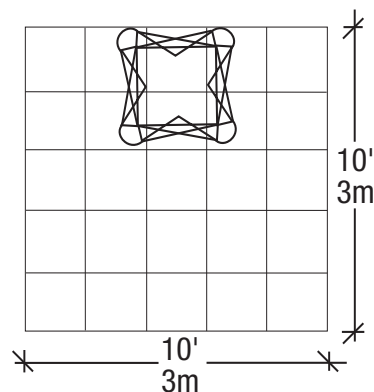

**ELEVATION**

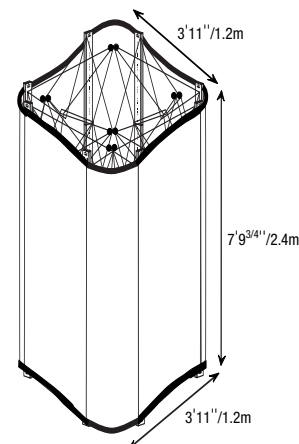

## Mercury Kit

## Classic Configuration

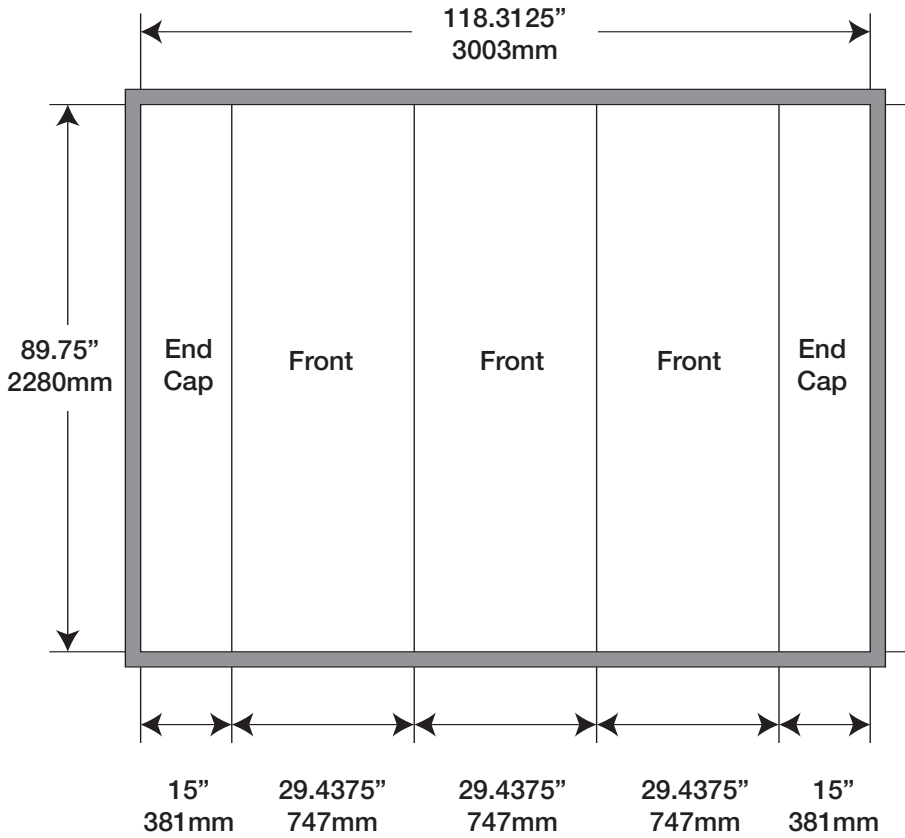

### Minimum Document Size\*

(with Bleed)

Width: 120.3125" x Height: 91.75"  
3054mm x 2331mm

(50% with Bleed)

Width: 60.15625" x Height: 45.875"  
1527mm x 1166mm

(25% with Bleed)

Width: 30.078125" x Height: 22.9375"  
764mm x 583mm

### Finished Size

Width: 118.3125" x Height: 89.75"  
3003mm x 2280mm

\*Your document size should encompass the crops and bleed area.

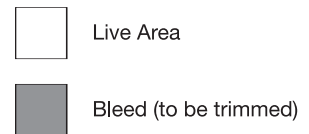

FLOOR PLAN

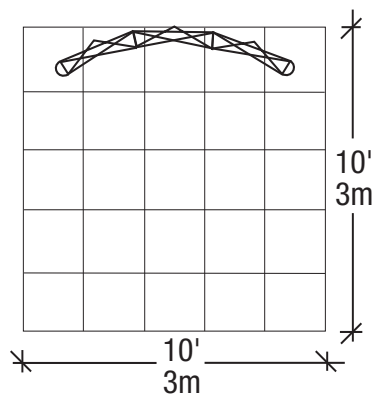

ELEVATION

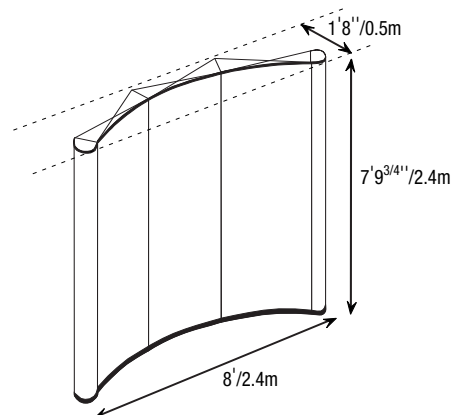

## Neptune Kit

## Classic Configuration

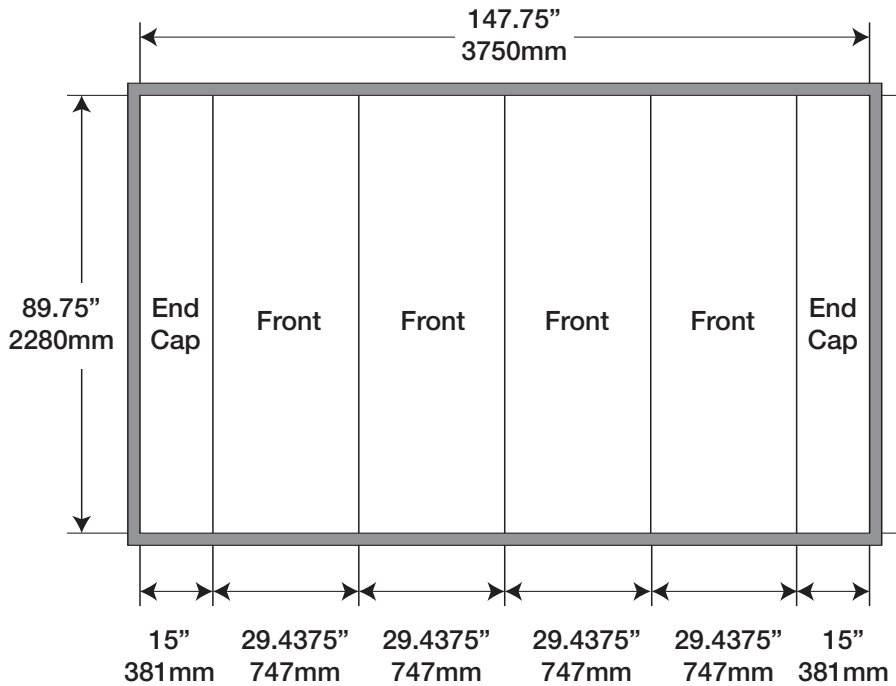

### Minimum Document Size\*

(with Bleed)

Width: 149.75" x Height: 91.75"  
3801mm x 2331mm

(50% with Bleed)

Width: 74.875" x Height: 45.875"  
1901mm x 1166mm

(25% with Bleed)

Width: 37.4375" x Height: 22.9375"  
951mm x 583mm

### Finished Size

Width: 147.75" x Height: 89.75"  
3750mm x 2280mm

\*Your document size should encompass the crops and bleed area.

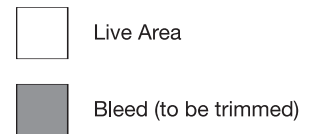

**FLOOR PLAN**

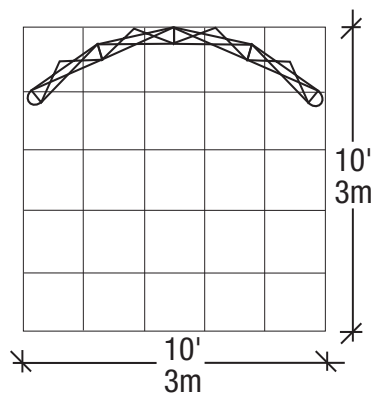

**ELEVATION**

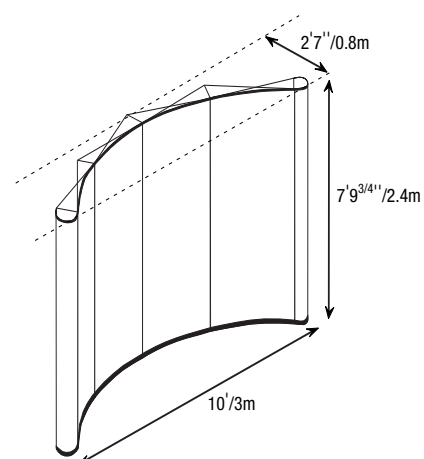

## Pluto Kit

## Classic Configuration

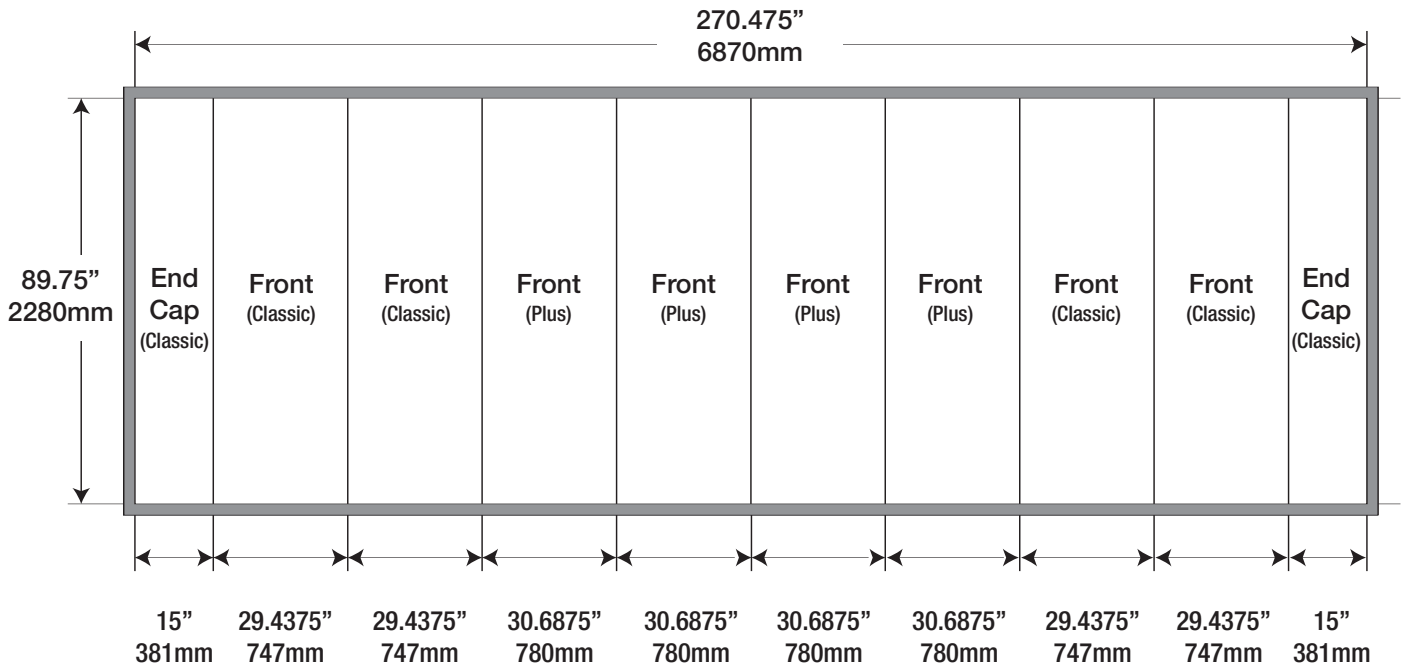

### Minimum Document Size\*

(with Bleed)

Width: 272.475" x Height: 91.75"  
6921mm x 2331mm

(50% with Bleed)

Width: 136.2375" x Height: 45.875"  
3460.5mm x 1166mm

(25% with Bleed)

Width: 68.11875" x Height: 22.9375"  
1730.25mm x 583mm

### Finished Size

Width: 270.475" x Height: 89.75"  
6870mm x 2280mm



Live Area



Bleed (to be trimmed)

\*Your document size should encompass the crops and bleed area.

### FLOOR PLAN

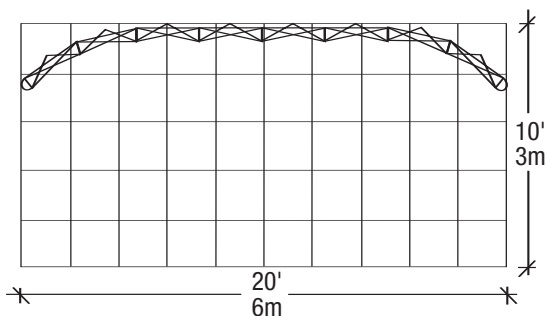

### ELEVATION

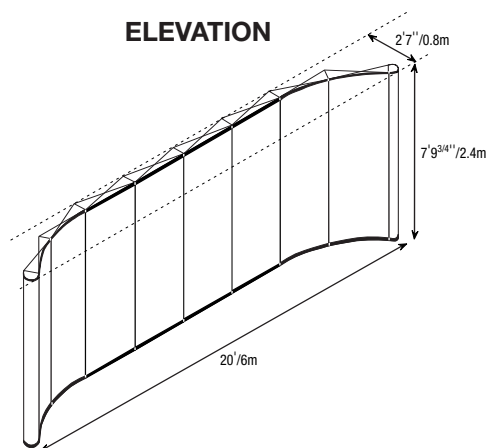

## Aquarius Kit

## Classic Configuration

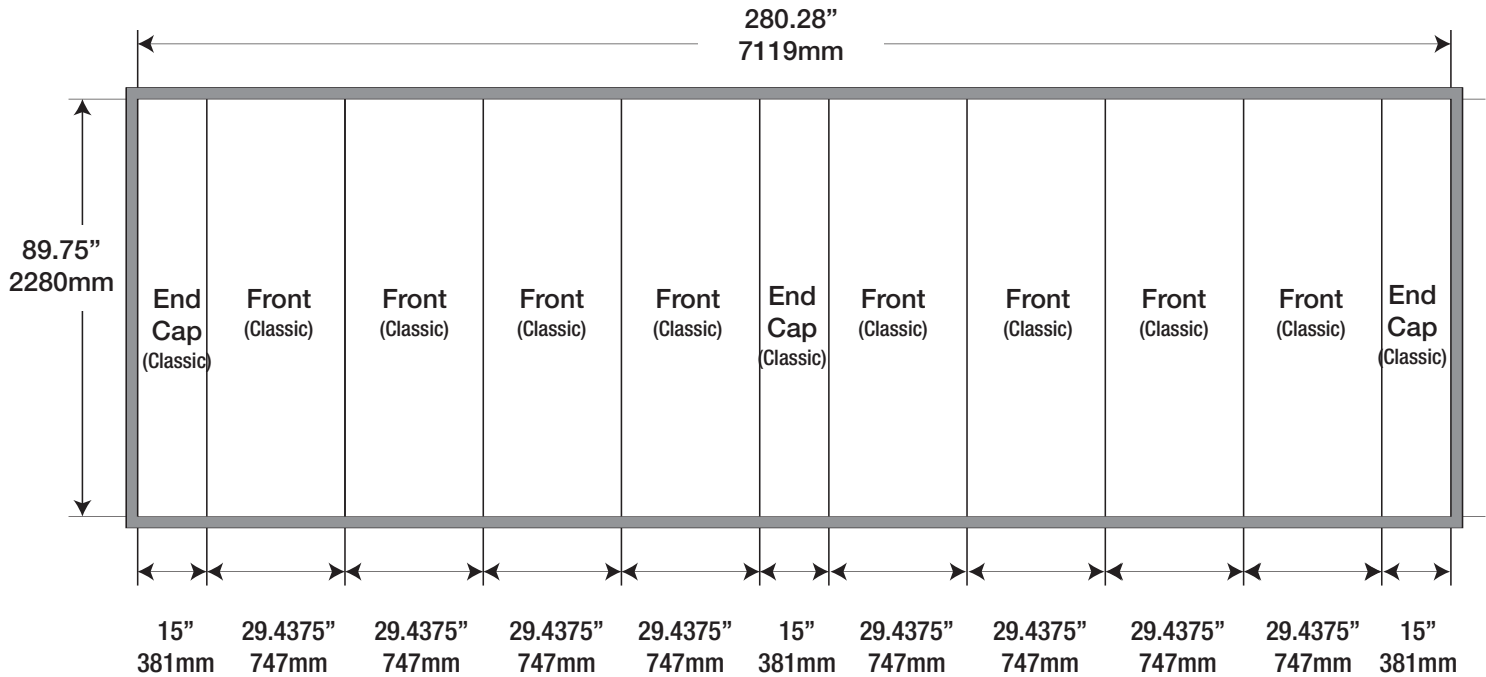

### Minimum Document Size\*

(with Bleed)  
Width: 282.28" x Height: 91.75"  
7170mm x 2331mm

(50% with Bleed)  
Width: 141.14" x Height: 45.875"  
3585mm x 1166mm

(25% with Bleed)  
Width: 70.57" x Height: 22.9375"  
1792mm x 583mm

**Finished Size**  
Width: 280.28" x Height: 89.75"  
7119mm x 2280mm

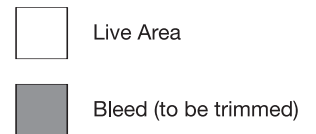

\*Your document size should encompass the crops and bleed area.

### FLOOR PLAN

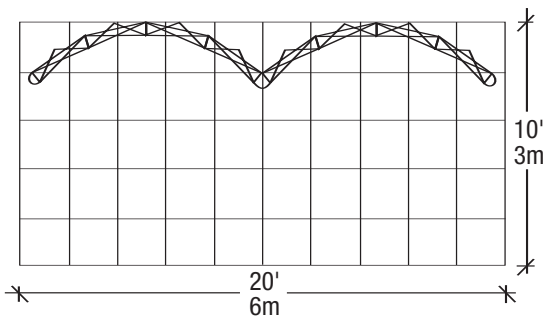

### ELEVATION

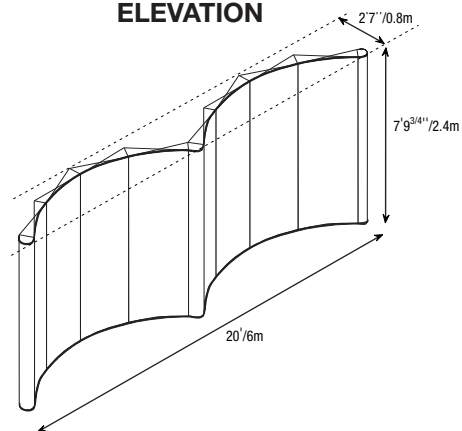

## Scorpion Kit

## Classic Configuration

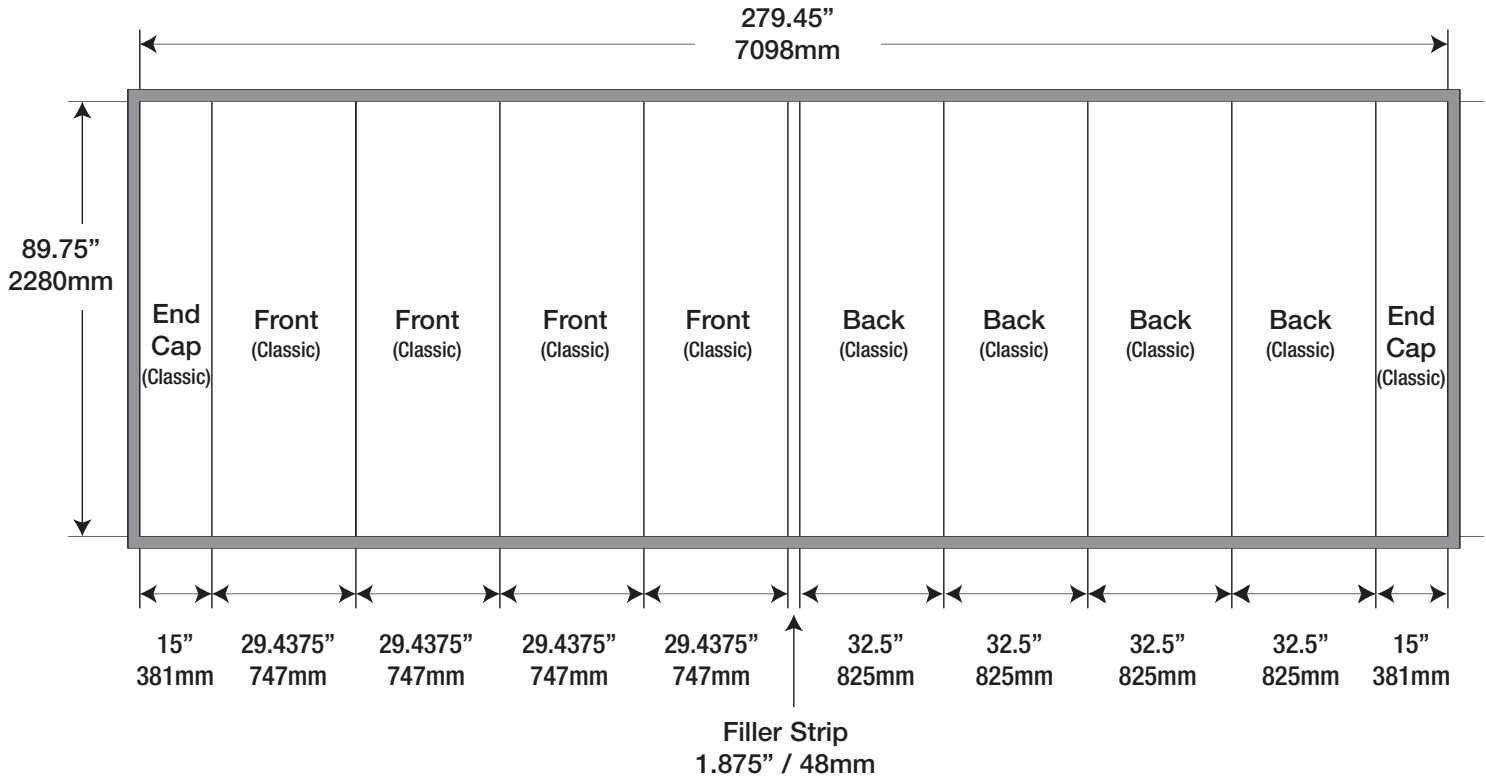

### Minimum Document Size\*

(with Bleed)

Width: 281.45" x Height: 91.75"  
7149mm x 2331mm

(50% with Bleed)

Width: 140.725" x Height: 45.875"  
3574.5mm x 1166mm

(25% with Bleed)  
Width: 70.3625" x Height: 22.9375"  
1787.25mm x 583mm

### Finished Size

Width: 279.45" x Height: 89.75"  
7098mm x 2280mm

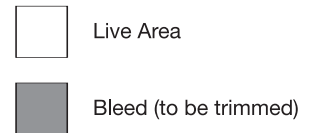

\*Your document size should encompass the crops and bleed area.

### FLOOR PLAN

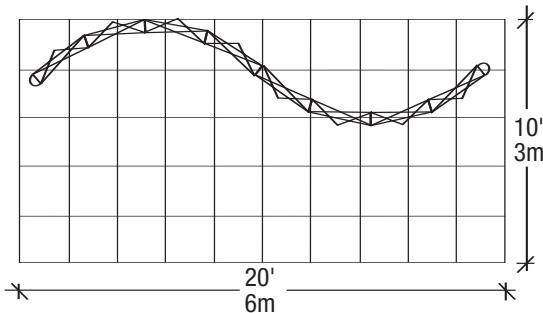

### ELEVATION

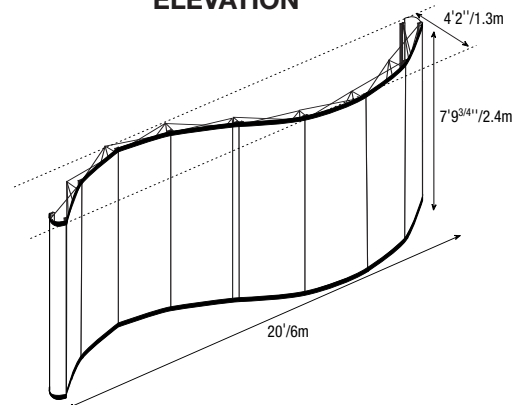

## Virgo Kit

## Plus Configuration

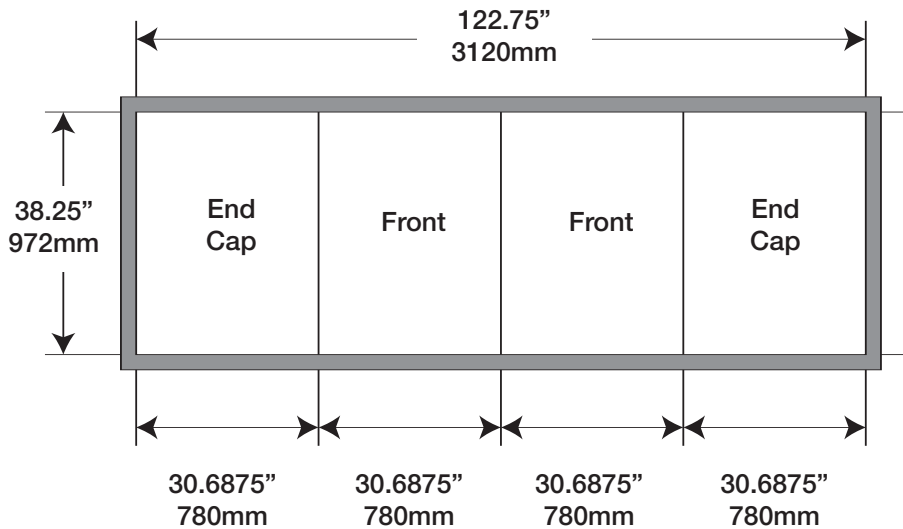

### Minimum Document Size\*

(with Bleed)  
Width: 124.75" x Height: 40.25"  
3171mm x 1022mm

(50% with Bleed)  
Width: 62.375" x Height: 20.125"  
1585.5mm x 511mm

(25% with Bleed)  
Width: 31.1875" x Height: 10.0625"  
792.25mm x 255.5

### Finished Size

Width: 122.75" x Height: 38.25"  
3120mm x 972mm

\*Your document size should encompass the crops and bleed area.

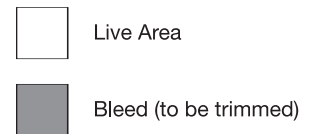

FLOOR PLAN

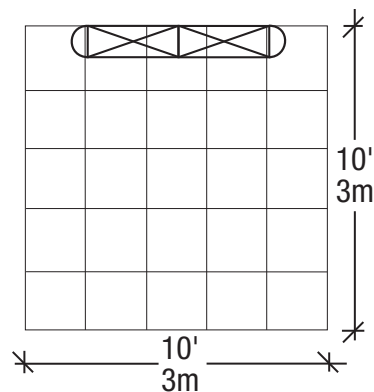

ELEVATION

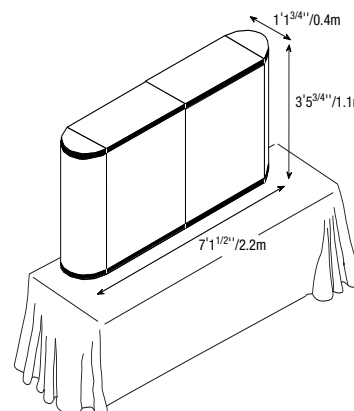



## Taurus Kit

## Plus Configuration

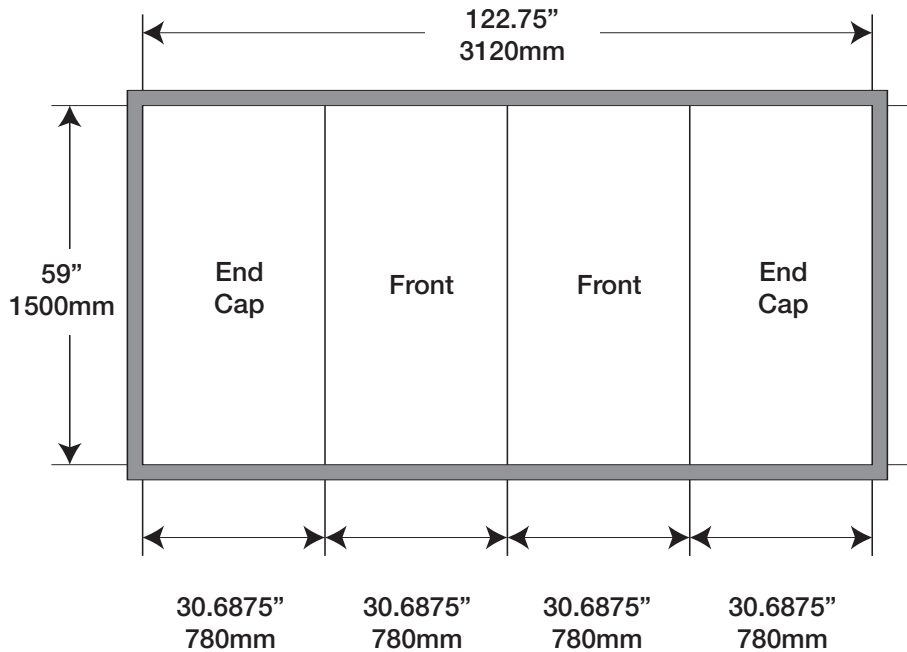

### Minimum Document Size\*

(with Bleed)

Width: 124.75" x Height: 61"  
3171mm x 1551mm

(50% with Bleed)

Width: 62.375" x Height: 30.5"  
1586mm x 776mm

(25% with Bleed)

Width: 31.1875" x Height: 15.25"  
793mm x 388mm

### Finished Size

Width: 122.75" x Height: 59"  
3120mm x 1500mm

\*Your document size should encompass the crops and bleed area.

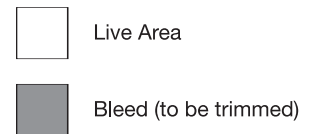

### FLOOR PLAN

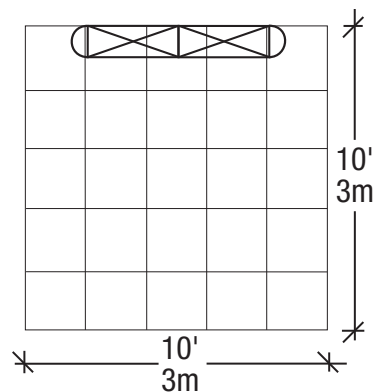

### ELEVATION

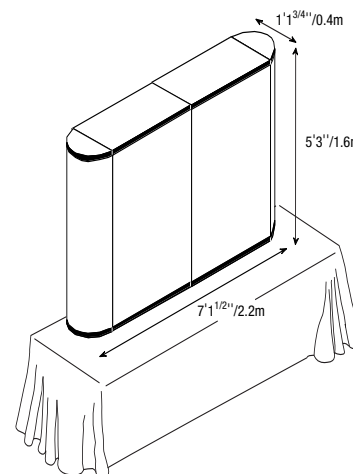

## Aries Kit

## Plus Configuration

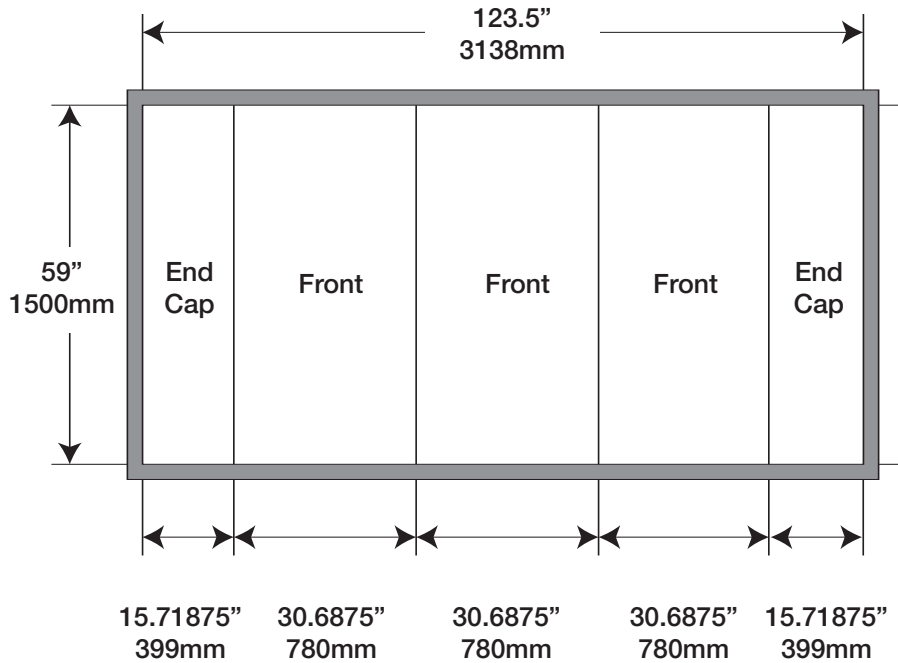

### Minimum Document Size\*

(with Bleed)  
Width: 125.5" x Height: 61"  
3189mm x 1551mm

(50% with Bleed)  
Width: 62.75" x Height: 30.5"  
1595mm x 776mm

(25% with Bleed)  
Width: 31.375" x Height: 15.25"  
798mm x 388mm

### Finished Size

Width: 123.5" x Height: 59"  
3138mm x 1500mm

\*Your document size should encompass the crops and bleed area.

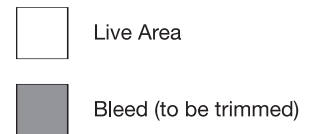

**FLOOR PLAN**

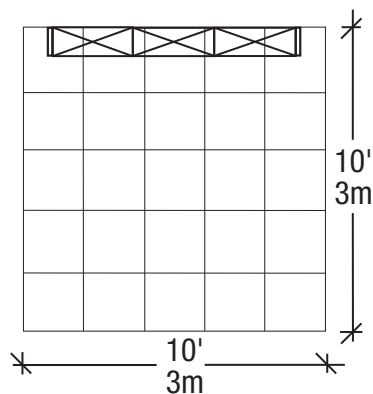

**ELEVATION**

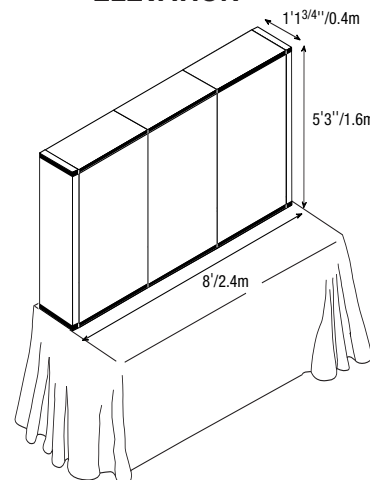

## Tuscana Kit

## Plus Configuration

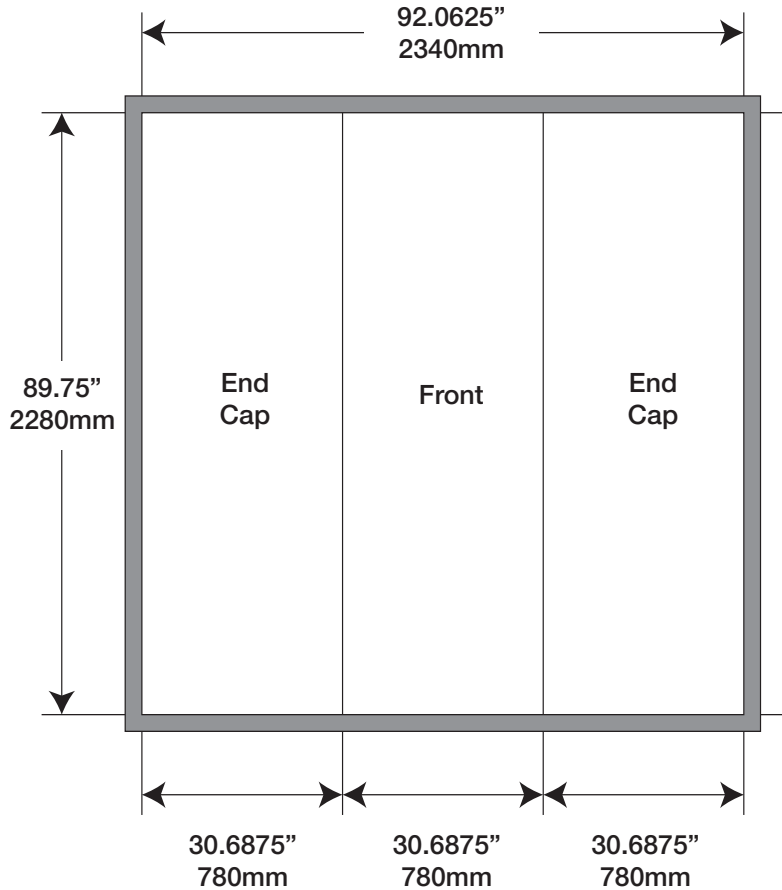

### Minimum Document Size\*

(with Bleed)

Width: 94.0625" x Height: 91.75"  
2391mm x 2331mm

(50% with Bleed)

Width: 47.03125" x Height: 45.875"  
1196mm x 1166mm

(25% with Bleed)

Width: 23.515625" x Height: 22.9375"  
598mm x 583mm

### Finished Size

Width: 92.0625" x Height: 89.75"  
2340mm x 2280mm

\*Your document size should encompass the crops and bleed area.

### FLOOR PLAN

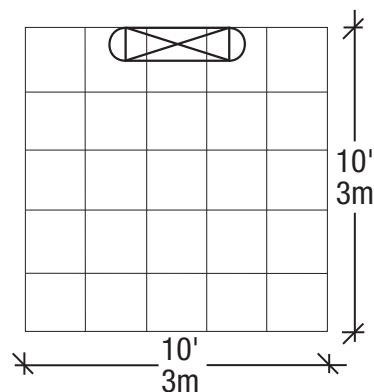

### ELEVATION

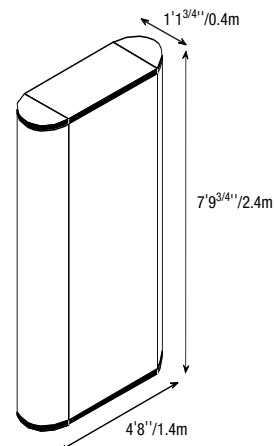

## Orion Kit

## Plus Configuration

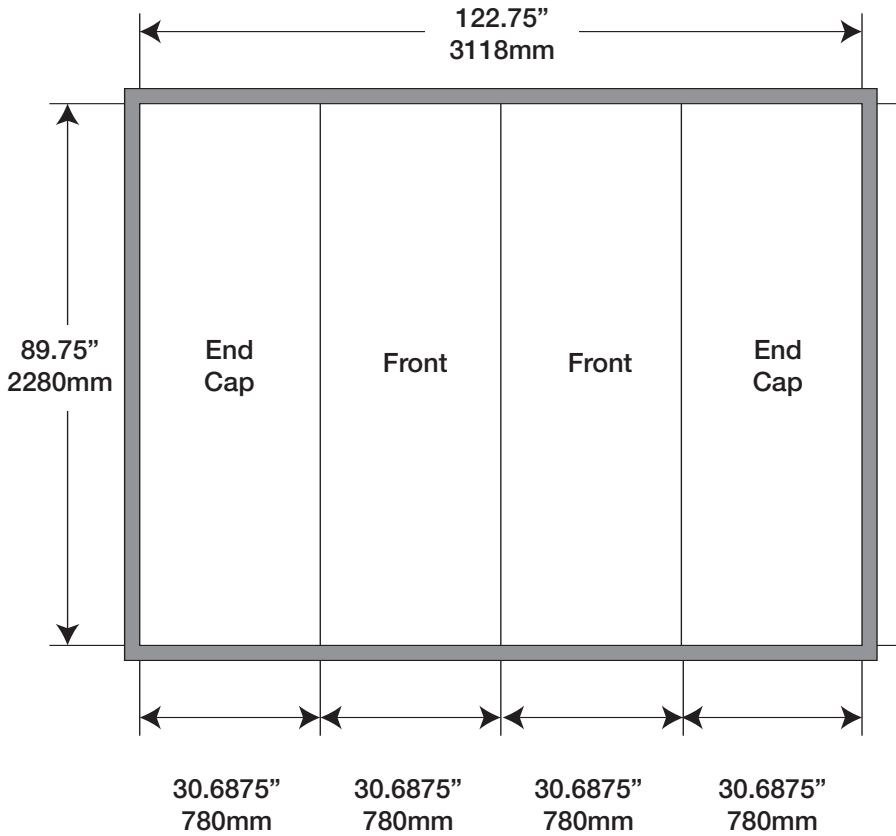

### Minimum Document Size\*

(with Bleed)

Width: 124.75" x Height: 91.75"  
3169mm x 2331mm

(50% with Bleed)

Width: 62.375" x Height: 45.875"  
1584.5mm x 1166mm

(25% with Bleed)

Width: 31.1875" x Height: 22.9375"  
792.25mm x 583mm

### Finished Size

Width: 122.75" x Height: 89.75"  
3118mm x 2280mm

\*Your document size should encompass the crops and bleed area.



Live Area



Bleed (to be trimmed)

**FLOOR PLAN**

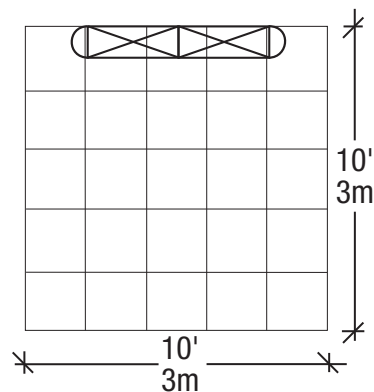

**ELEVATION**

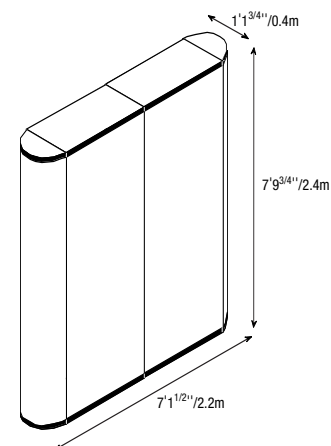

## Gateway Kit

## Plus Configuration

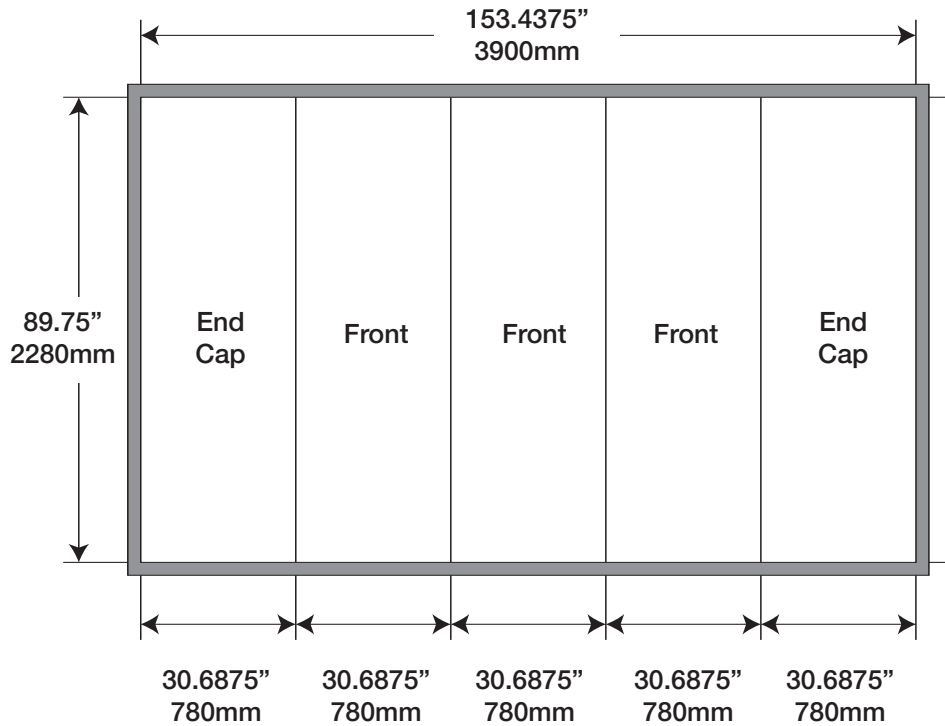

### Minimum Document Size\*

(with Bleed)

Width: 155.4375" x Height: 91.75"  
3951mm x 2331mm

(50% with Bleed)

Width: 77.71875" x Height: 45.875"  
1975mm x 1166mm

(25% with Bleed)

Width: 38.859375" x Height: 22.9375"  
988mm x 583mm

### Finished Size

Width: 153.4375" x Height: 89.75"  
3900mm x 2280mm

\*Your document size should encompass the crops and bleed area.



Live Area



Bleed (to be trimmed)

**FLOOR PLAN**

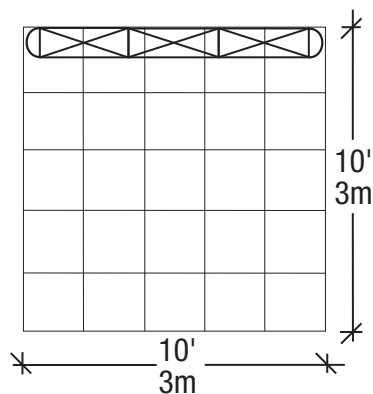

**ELEVATION**

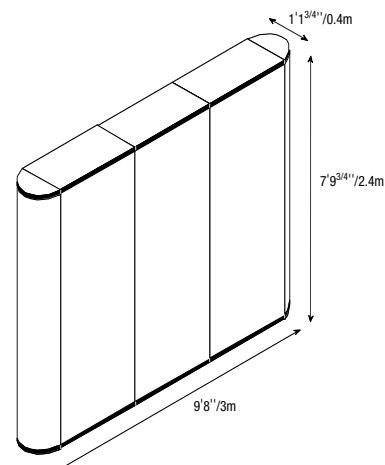

## Tempest Kit Plus Configuration

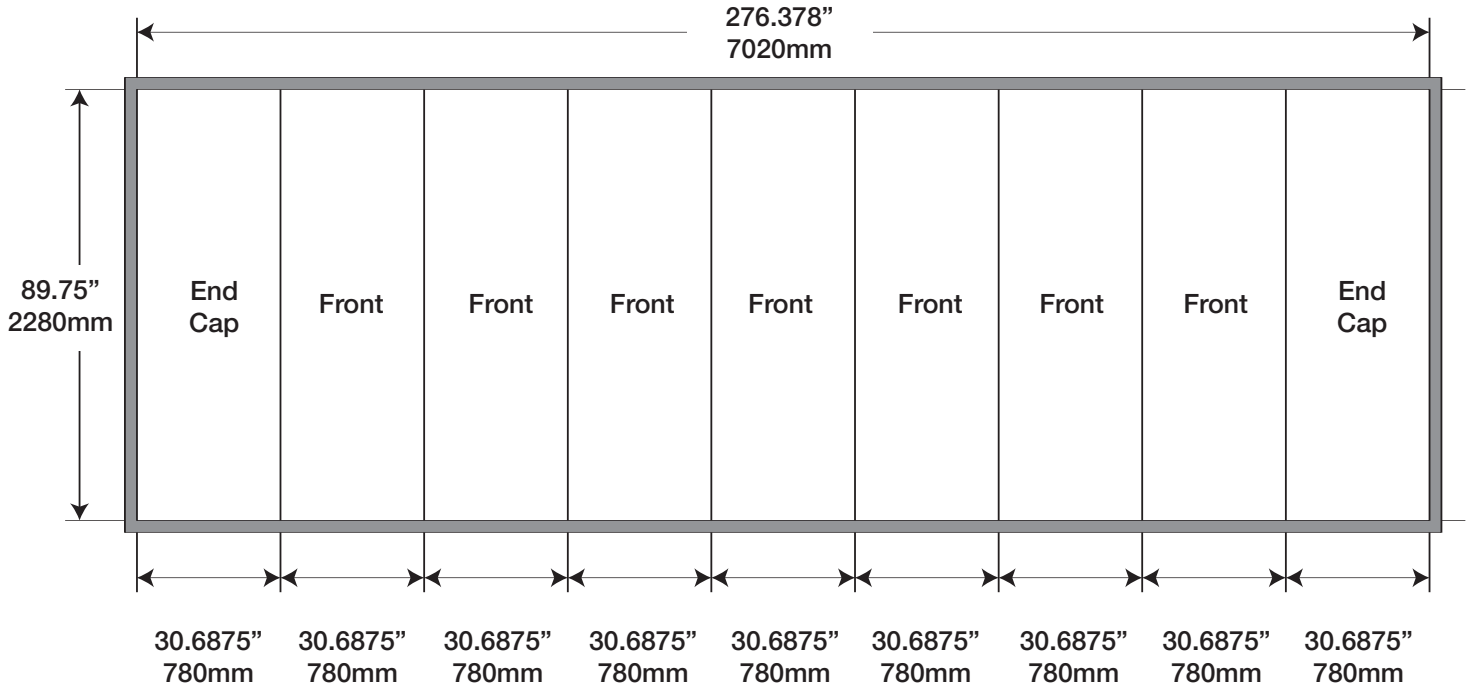

### Minimum Document Size\*

(with Bleed)

Width: 278.378" x Height: 91.75"  
7071mm x 2331mm

(50% with Bleed)

Width: 139.189" x Height: 45.875"  
3535.5mm x 1166mm

(25% with Bleed)

Width: 69.5945" x Height: 22.9375"  
1767.75mm x 583mm

### Finished Size

Width: 276.378" x Height: 89.75"  
7020mm x 2280mm

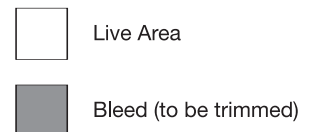

\*Your document size should encompass the crops and bleed area.

### FLOOR PLAN

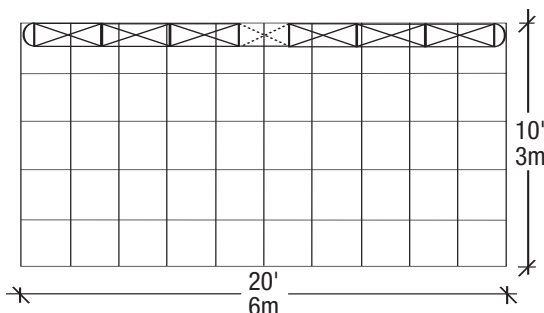

### ELEVATION

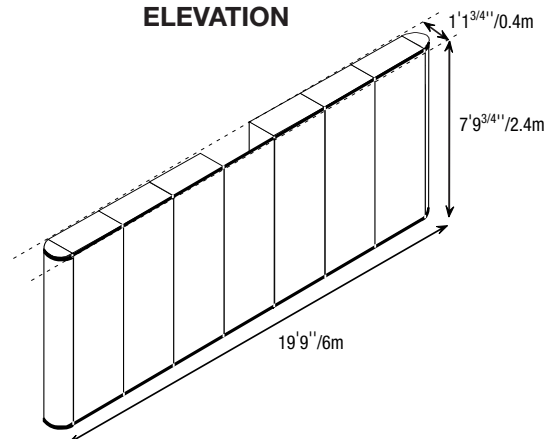

## Gemini Kit

## Plus Configuration

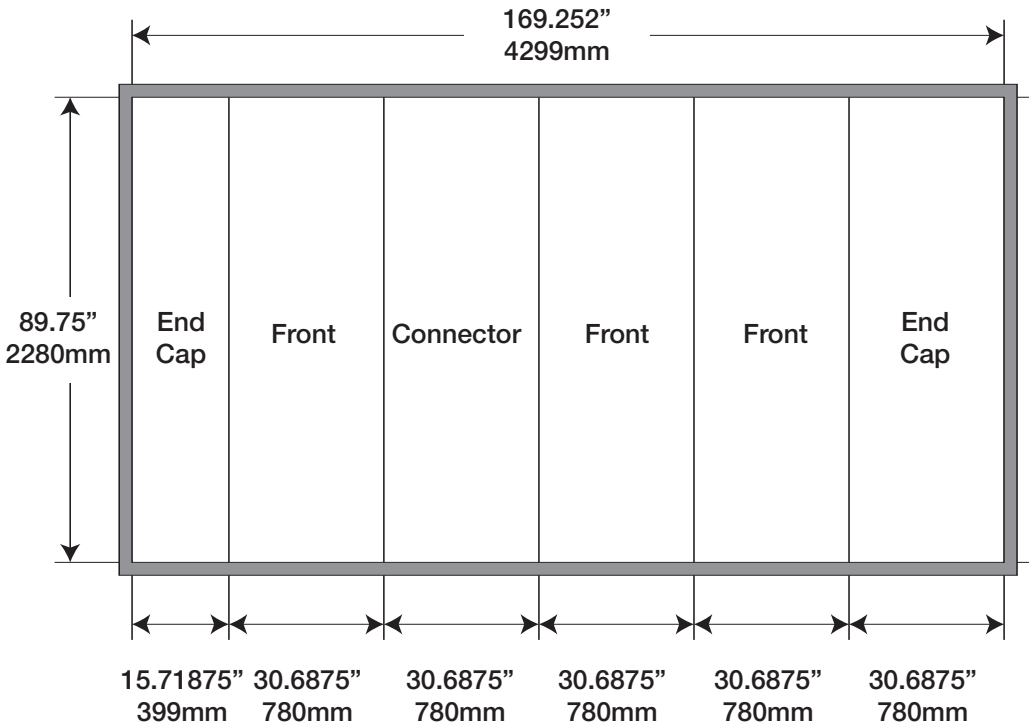

### Minimum Document Size\*

(with Bleed)  
Width: 171.252" x Height: 91.75"  
4350mm x 2331mm

(50% with Bleed)  
Width: 85.626" x Height: 45.875"  
2175mm x 1166mm

(25% with Bleed)  
Width: 42.813" x Height: 22.9375"  
1087.5mm x 583mm

### Finished Size

Width: 169.252" x Height: 89.75"  
4299mm x 2280mm

\*Your document size should encompass the crops and bleed area.

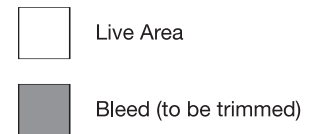

**FLOOR PLAN**

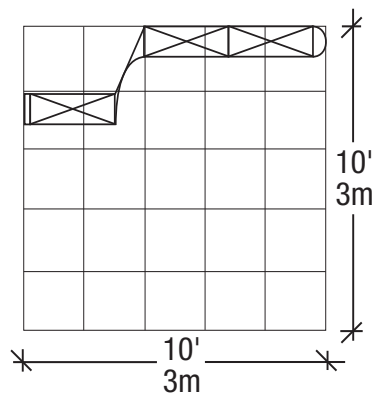

**ELEVATION**

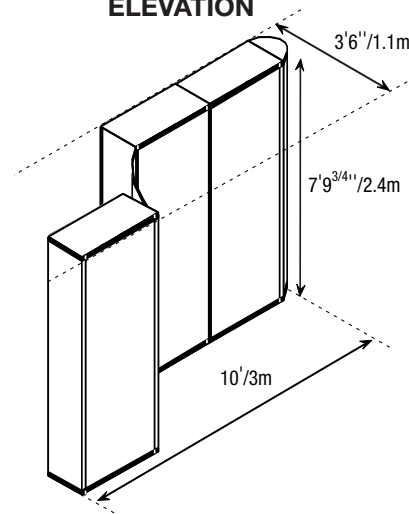

## Atlantis Kit

## Integrated Configuration

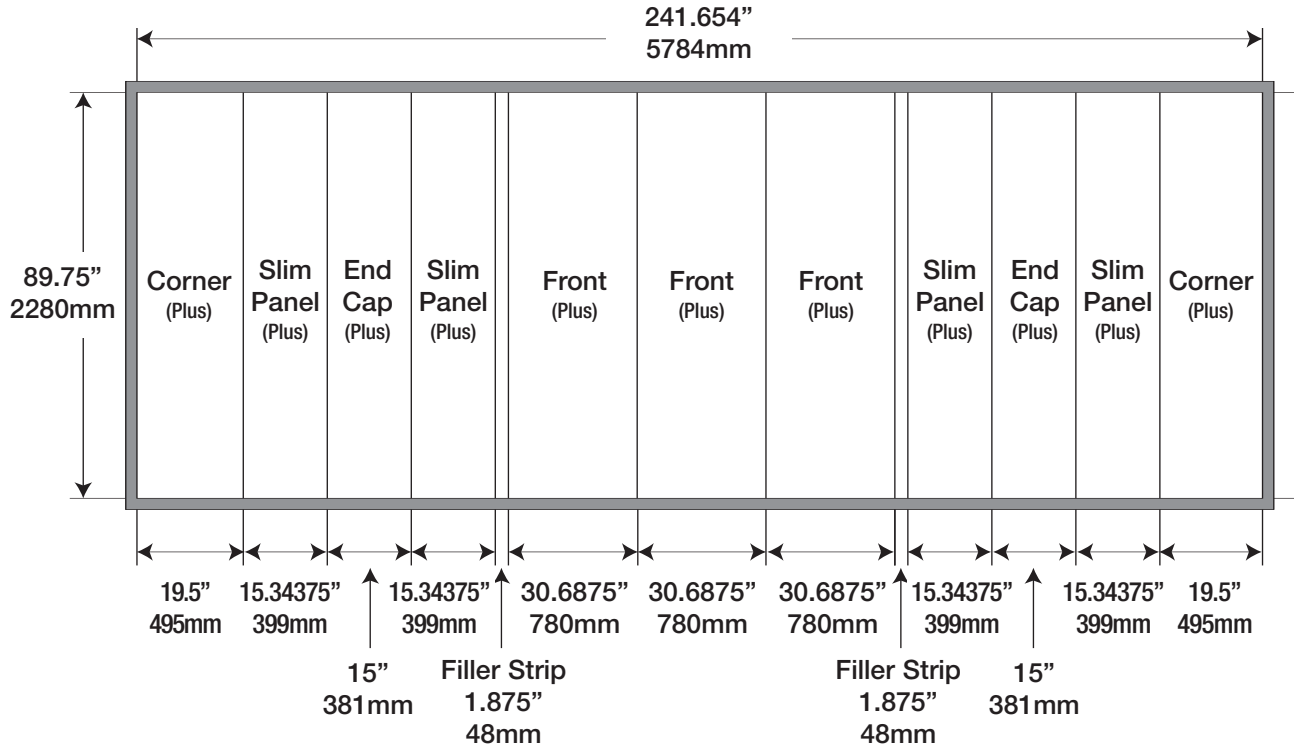

### Minimum Document Size\*

(with Bleed)

Width: 243.654" x Height: 91.75"  
5835mm x 2331mm

(50% with Bleed)

Width: 121.827" x Height: 45.875"  
2917.5mm x 1166mm

(25% with Bleed)

Width: 60.9135" x Height: 22.9375"  
1458.75mm x 583mm

### Finished Size

Width: 241.654" x Height: 89.75"  
5784mm x 2280mm



Live Area



Bleed (to be trimmed)

\*Your document size should encompass the crops and bleed area.

### FLOOR PLAN

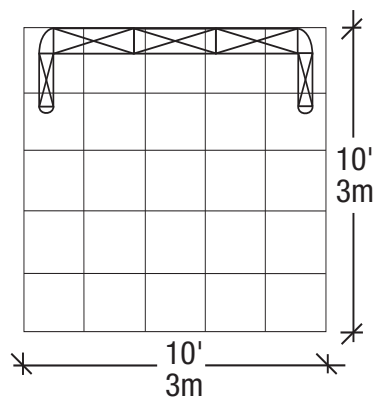

### ELEVATION

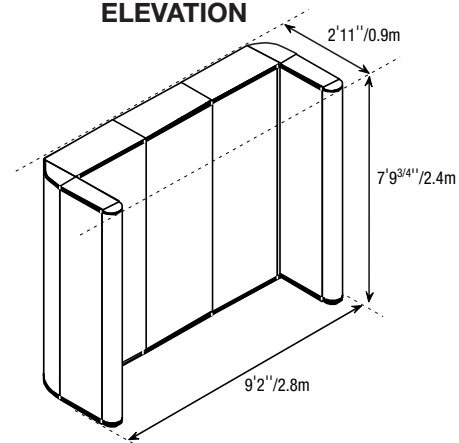



## Chiron Kit

## Integrated Configuration

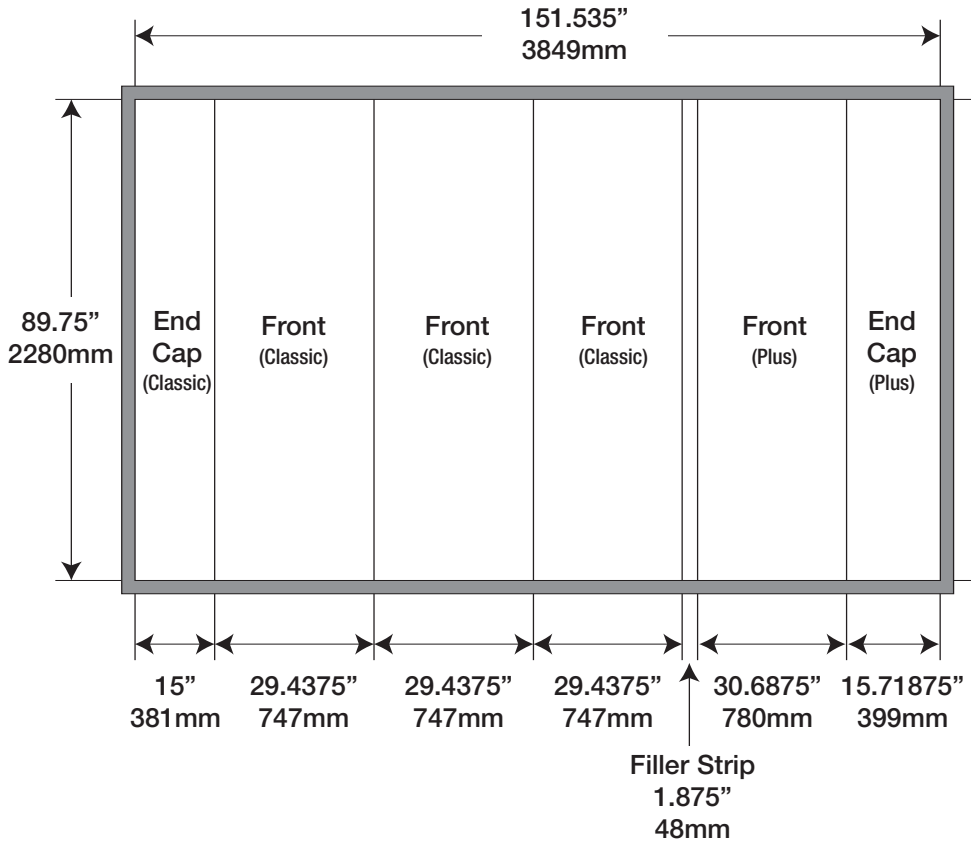

### Minimum Document Size\*

(with Bleed)

Width: 153.535" x Height: 91.75"  
3900mm x 2331mm

(50% with Bleed)

Width: 76.7675" x Height: 45.875"  
1950mm x 1166mm

(25% with Bleed)

Width: 38.38375" x Height: 22.9375"  
975mm x 583mm

### Finished Size

Width: 151.535" x Height: 89.75"  
3849mm x 2280mm

\*Your document size should encompass the crops and bleed area.

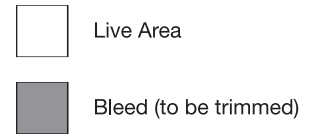

FLOOR PLAN

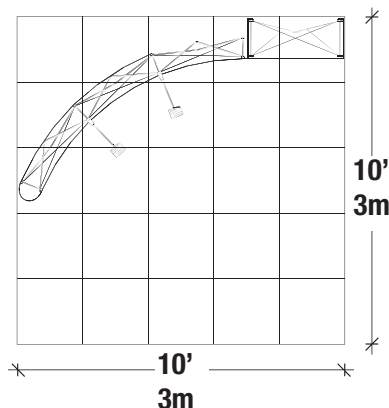

ELEVATION

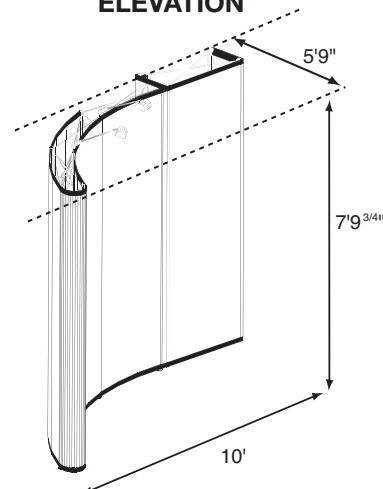

## Chiron Kit A

## Integrated Configuration

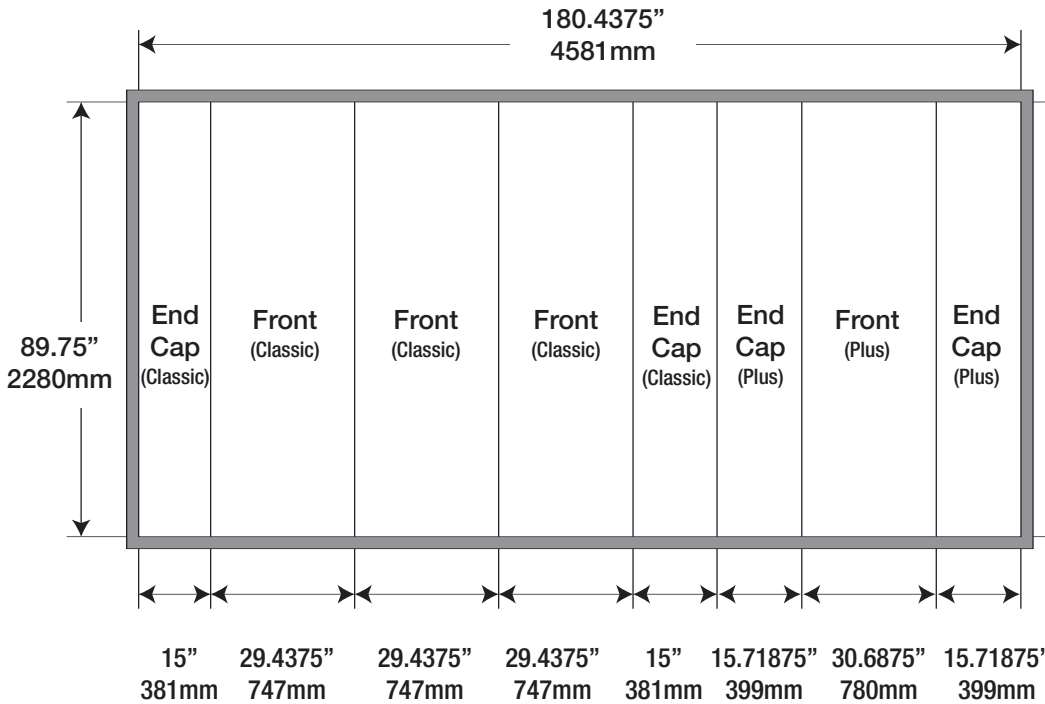

### Minimum Document Size\*

(with Bleed)  
Width: 182.4375" x Height: 91.75"  
4632mm x 2331mm

(50% with Bleed)  
Width: 91.21875" x Height: 45.875"  
2316mm x 1166mm

(25% with Bleed)  
Width: 45.6094" x Height: 22.9375"  
1158mm x 583mm

### Finished Size

Width: 180.4375" x Height: 89.75"  
4581mm x 2280mm

\*Your document size should encompass the crops and bleed area.

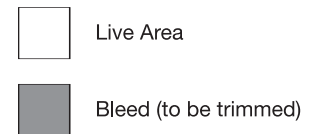

**FLOOR PLAN**

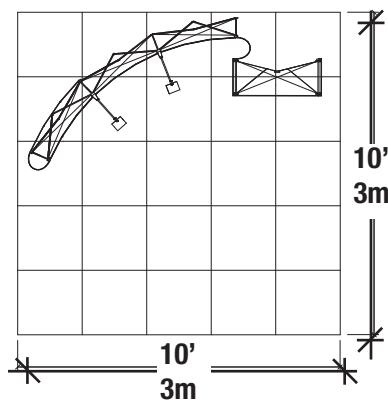

**ELEVATION**

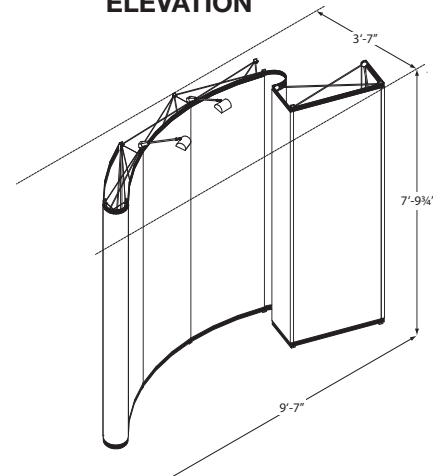

## Saturn Kit

## Integrated Configuration

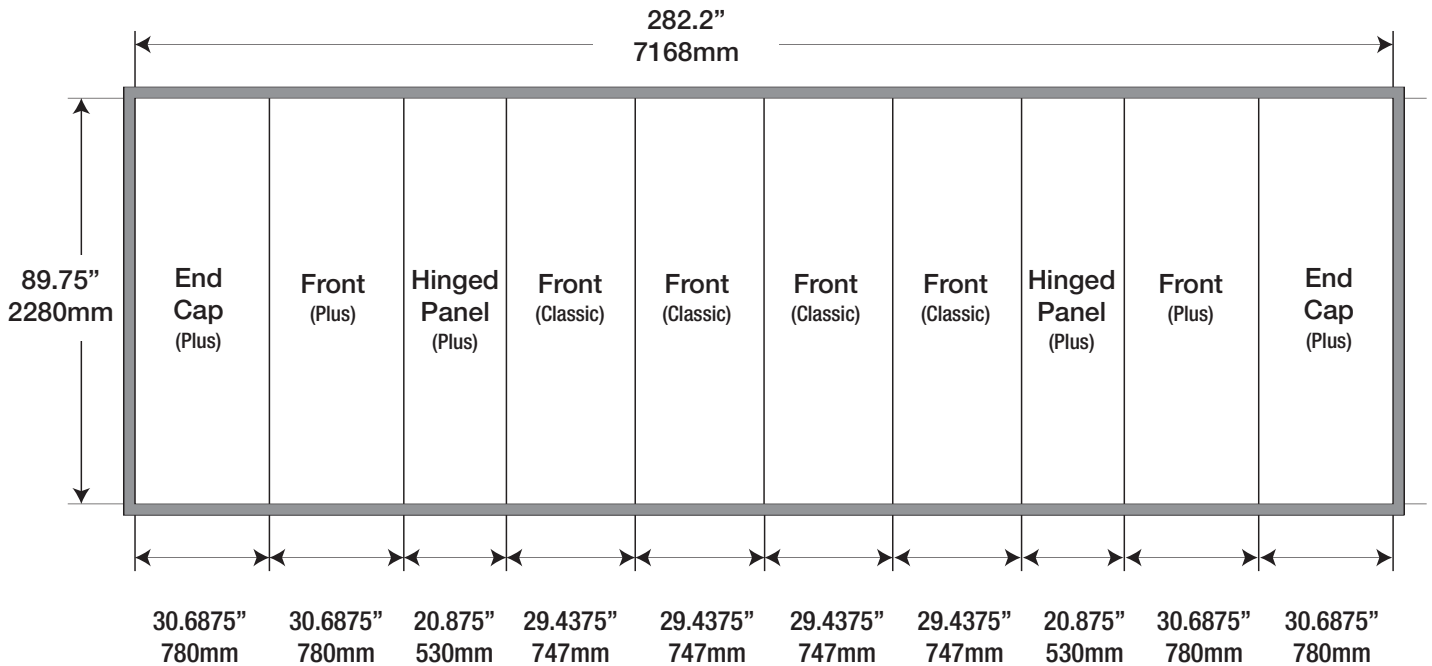

### Minimum Document Size\*

(with Bleed)

Width: 284.2" x Height: 91.75"  
7219mm x 2331mm

(50% with Bleed)

Width: 142.1" x Height: 45.875"  
3609.5mm x 1166mm

(25% with Bleed)

Width: 71.05" x Height: 22.9375"  
1804.75mm x 583mm

### Finished Size

Width: 282.2" x Height: 89.75"  
7168mm x 2280mm

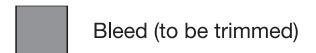

\*Your document size should encompass the crops and bleed area.

FLOOR PLAN

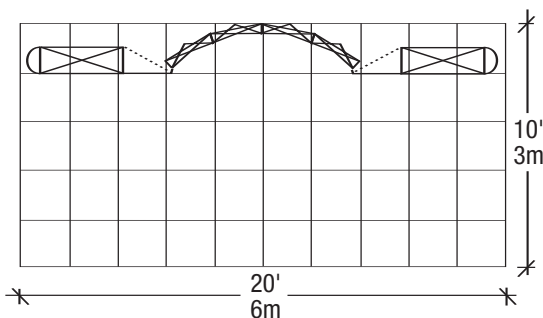

ELEVATION

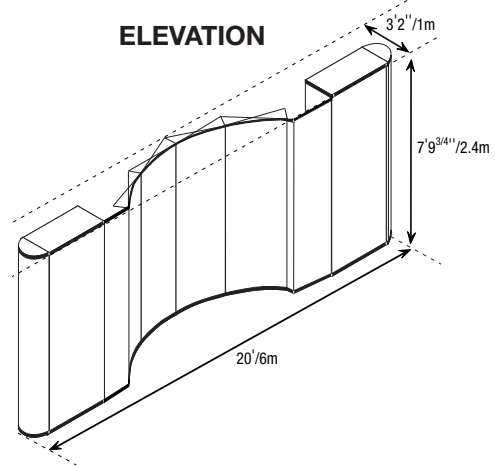

## Rigel Kit

## Classic Configuration

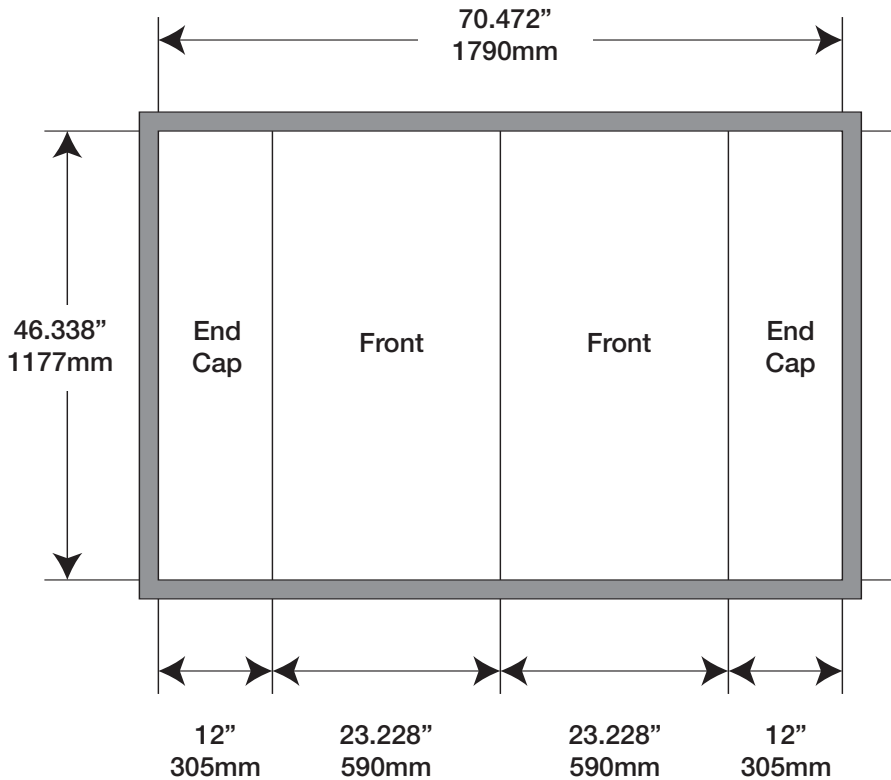

### Minimum Document Size\*

(with Bleed)

Width: 90.875" x Height: 61"  
1841mm x 1228mm

(50% with Bleed)

Width: 45.4375" x Height: 30.5"  
920.5mm x 614mm

(25% with Bleed)

Width: 22.71875" x Height: 15.25"  
460.25mm x 307mm

### Finished Size

Width: 88.875" x Height: 59"  
1790mm x 1177mm

\*Your document size should encompass the crops and bleed area.

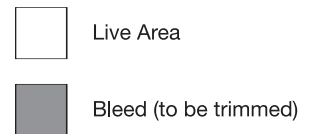

### FLOOR PLAN

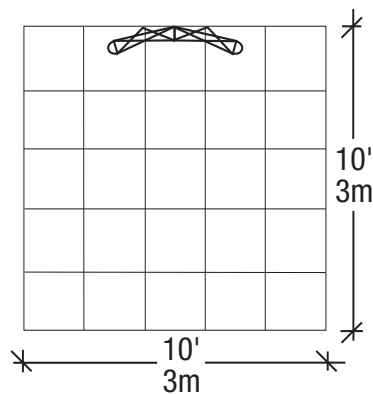

### ELEVATION

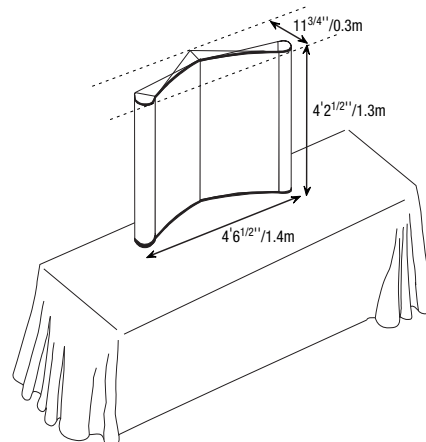

## Stratos Kit

## Integrated Configuration

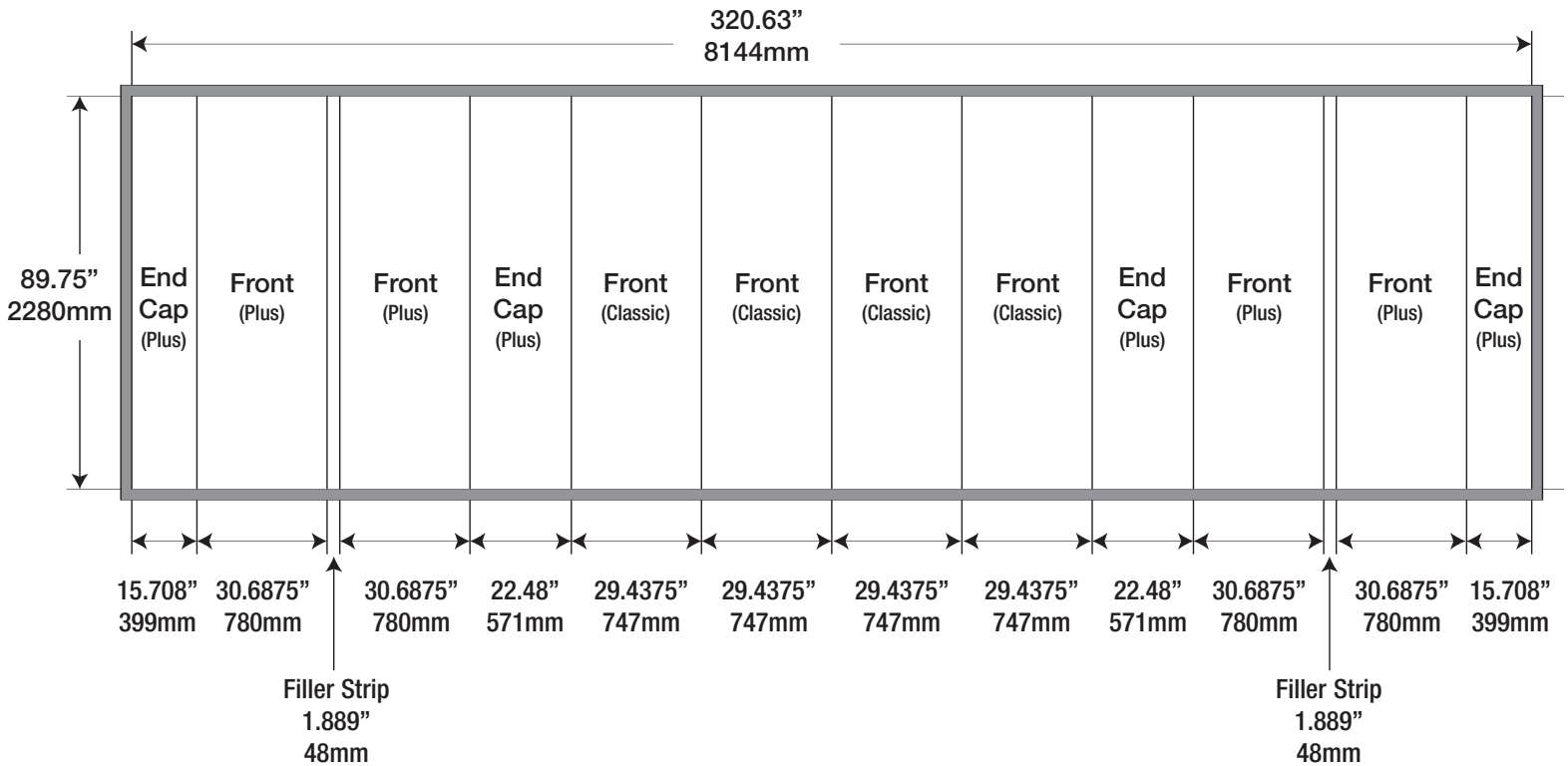

### Minimum Document Size\*

(with Bleed)

Width: 322.638" x Height: 91.75"  
8195mm x 2331mm

(50% with Bleed)

Width: 161.319" x Height: 45.875"  
4097.5mm x 1166mm

(25% with Bleed)

Width: 80.6595" x Height: 22.9375"  
2048.75mm x 583mm

### Finished Size

Width: 320.83" x Height: 89.75"  
8144mm x 2280mm



Live Area



Bleed (to be trimmed)

\*Your document size should encompass the crops and bleed area.

FLOOR PLAN

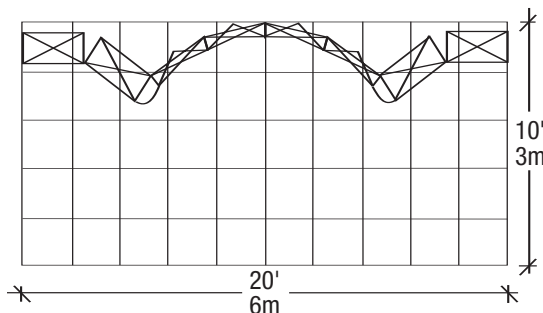

ELEVATION

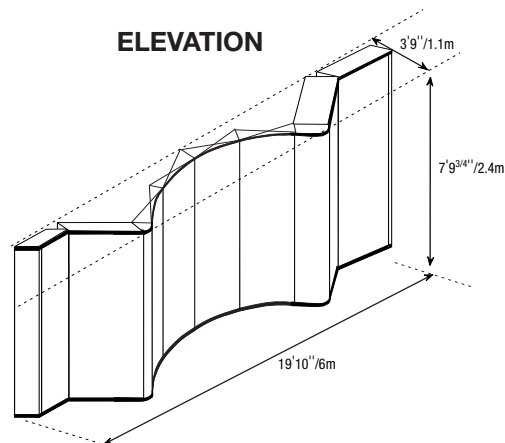

## Instructions for Mounting Graphic Panels on Nomadic Instand (Classic)

Nomadic recommends that you order the appropriate magnetic mounting materials to produce panels. Please refer to the Graphics Production Materials page in the Accessories section of your green Nomadic Display Answer Book I.

### Before you begin

Read through these instructions and refer to the Graphic Specification Table for panel trim dimensions. It is recommended that you set up your Instand frame so that your completed graphic panels can be hung and checked. If necessary, stiffeners and magnetic tape can be removed and relocated before the adhesive fully sets.

### Step 1 - Lay Down the Strip

Place the graphic panel (trimmed to exact finished sizes from the Specifications Table) face down on a protected surface.

### Step 2 - Affix the Adhesive Tape

Lay the double-backed tape down along the full width of the graphic at the top and bottom edges. Press firmly on backing to affix tape to the graphic strip. Remove the backing to expose the tape's upper layer of adhesive. See Figure 1.

### Step 3 - Attach Stiffeners and/or Loop Tape

The matte surface of the stiffener should be seen on the front of the display. Place the bottom 1" / 25mm of the stiffener on the exposed adhesive tape (glossy side up). Be sure to use notched or punched stiffeners at the top of the strip. Take care to center the stiffener onto the end of the strip. Once the stiffener is correctly aligned press it firmly into place along its entire length. A roller is recommended to ensure a uniform bond. Follow the same steps to attach the bottom stiffener. NOTE: End cap stiffeners are thinner .015" / .3mm thick.

### Step 4 - Lay Down the Magnetic Tape

Apply the magnetic tape  $1/16$ " / 1.5mm from the outer edge of the graphic. Peel off the protective backing on the adhesive side of the tape as you unroll and lay it from the bottom edge of the top stiffener to the top edge of the bottom stiffener. Again, a roller is recommended to ensure a uniform bond. See Figure 2.

## Step 5 - Check Finished Panels

Be sure your measurements are correct. Stiffeners will extend 1<sup>1/2</sup>" / 39mm from top and bottom of the graphic panel. Magnetic tape will be about 1<sup>1/16</sup>" / 1.5mm from the outer edge of the panel. There should be no gaps between adjacent panels. Inspect the panels promptly by hanging them on your Instand frame. Adjustments can be made before the adhesive sets.

For light box transparency mounting, see Figure 3.

### **Warning —**

**This kit is made available exclusively to authorized dealers of Nomadic Instand. Nomadic Display assumes no responsibility for damage to graphic strips or panels in the use of this kit. Using these materials with products other than the Nomadic Instand magnetic mounting system may not result in a high quality display.**

**Nomadic Display has made every effort to ensure that the enclosed specifications are completely accurate. However, these dimensions should serve as guidelines only. In order to achieve a genuinely precise fit, IT IS STRONGLY RECOMMENDED that test panels be created using scrap materials, prior to creating final graphic panels.**

## Example of Stiffener and Magnet Mounting

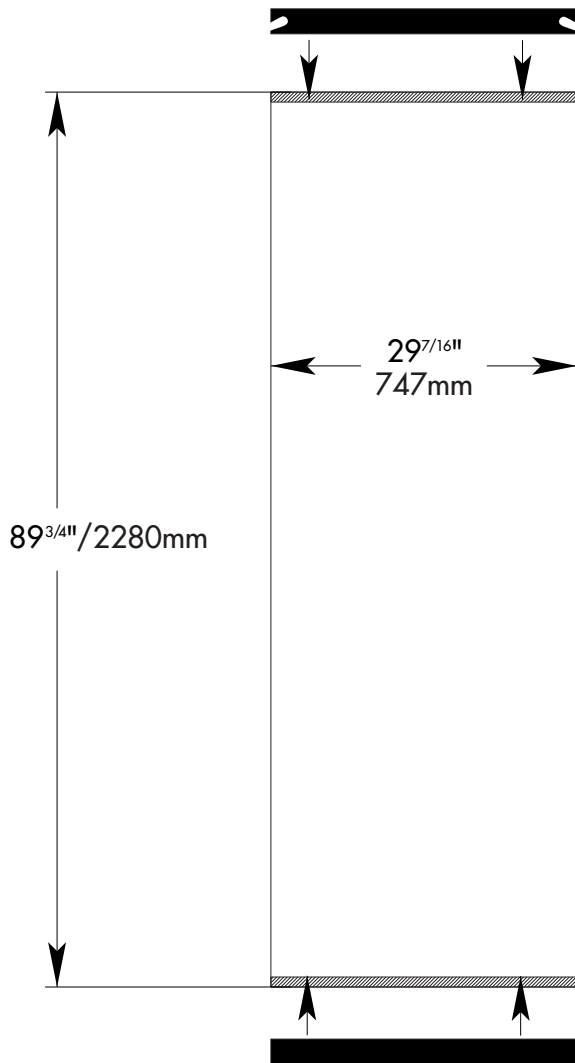

**Fig. 1**

Apply 1" / 25mm double backed adhesive tape to top and bottom

Attach top and bottom stiffeners

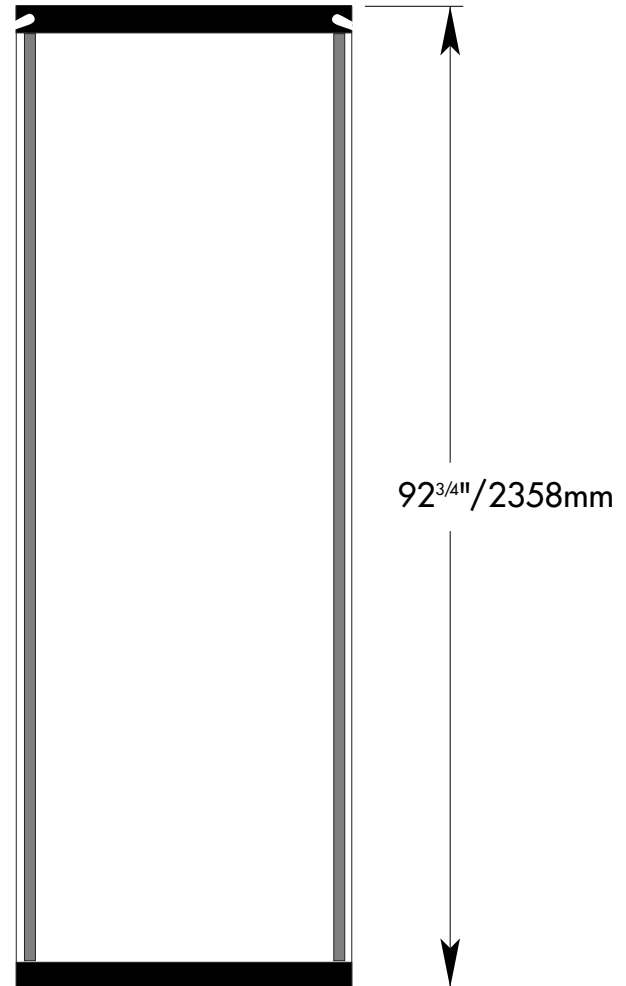
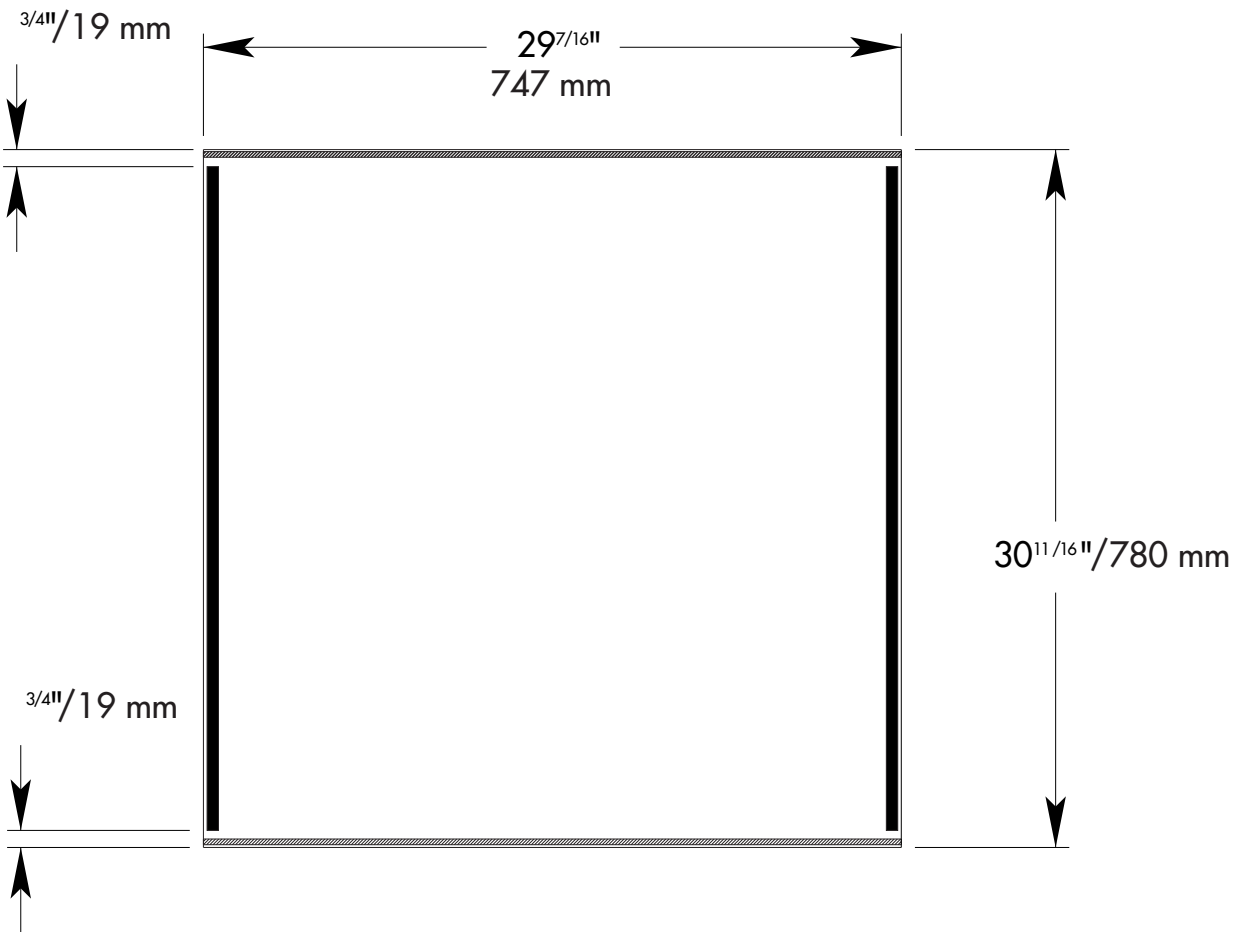

**Fig. 2**

Apply magnetic tape  $\frac{1}{16}''/1.5\text{mm}$  from outer edges



## Example of Light Box Transparency Mounting



**Fig. 3**

Apply  $\frac{1}{4}$ " / 6mm hook Velcro® to top and bottom  
Apply  $\frac{1}{2}$ " / 12mm magnetic tape  $\frac{1}{16}$ " / 1.5mm from outer edges

Name

**One Quad High Classic Panel**

Equivalent Fabric/Graphic Code

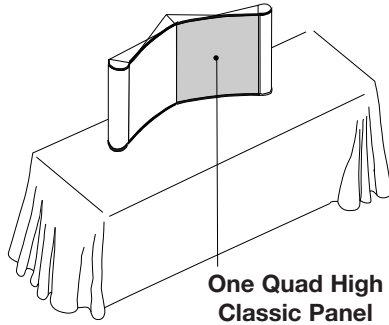
**FPC1/INK-13030**

**Trim Size:**  $29^{7/16}{}_{\text{W}} \times 28^{3/16}{}_{\text{H}} / 747_{\text{W}} \times 716_{\text{mmH}}$ 
**Stiffener Punch (Top/Bottom):** Notched/Plain

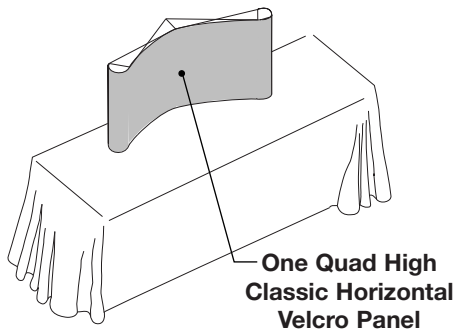
**Required Stiffeners (Top/Bottom):** GSCLT, GSCLB

**One Quad High Classic Horizontal Velcro Panel**
**FPC1HO/INK-18730**

**Trim Size:**  $87{}_{\text{W}} \times 32^{1/2}{}_{\text{H}} / 2210_{\text{W}} \times 826_{\text{mmH}}$

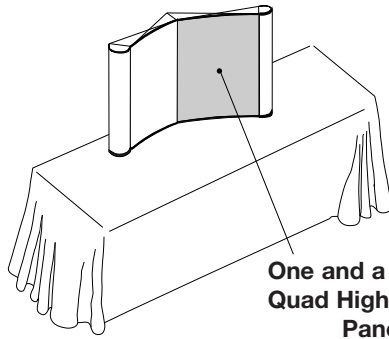
Name

Equivalent Fabric/Graphic Code

**One and a Quarter Quad High Classic Panel**
**FPC1 1H/INK-13040**

One and a Quarter  
Quad High Classic  
Panel

**Trim Size:**  $29^{7/16}{}_{\text{W}} \times 38^{1/4}{}_{\text{H}} / 747_{\text{W}} \times 972\text{mm}_{\text{H}}$ 
**Stiffener Punch (Top/Bottom):** Notched/Plain

**Required Stiffeners (Top/Bottom):** GSCLT, GSCLB

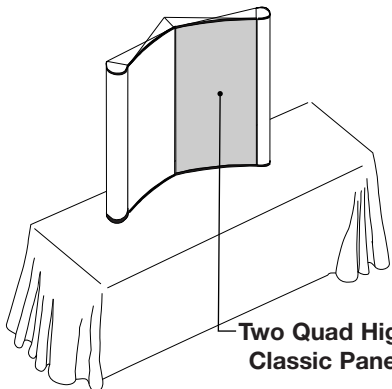
**Two Quad High Classic Panel**
**FPC2/INK-23060**

Two Quad High  
Classic Panel

**Trim Size:**  $29^{7/16}{}_{\text{W}} \times 59{}_{\text{H}} / 747_{\text{W}} \times 1500\text{mm}_{\text{H}}$ 
**Stiffener Punch (Top/Bottom):** Notched/Plain

**Required Stiffeners (Top/Bottom):** GSCLT, GSCLB

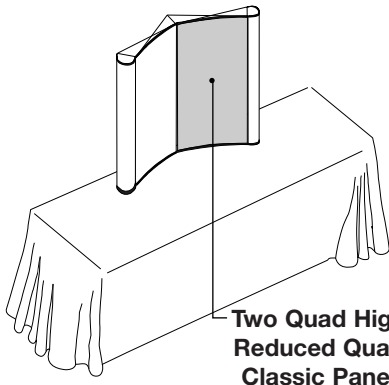
**Two Quad High Reduced Quad Classic Panel**
**FPC2R/INK-22447**

Two Quad High  
Reduced Quad  
Classic Panel

**Trim Size:**  $23^{7/32}{}_{\text{W}} \times 46^{11/32}{}_{\text{H}} / 590_{\text{W}} \times 1177\text{mm}_{\text{H}}$ 
**Stiffener Punch (Top/Bottom):** Notched/Plain

**Required Stiffeners (Top/Bottom):** GSCLTR, GSCLBR

Name

Equivalent Fabric/Graphic Code

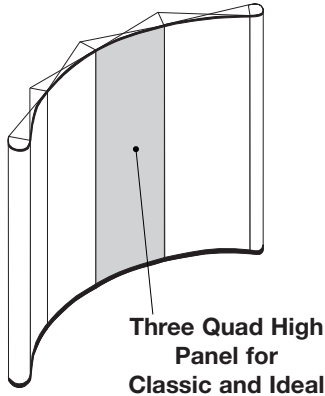
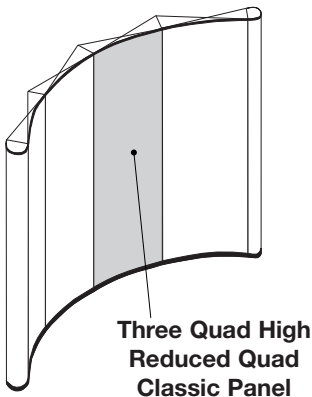
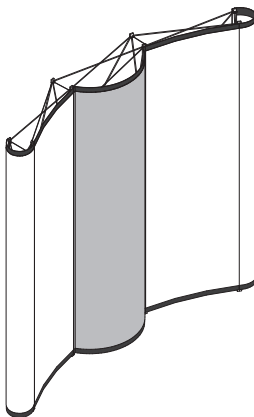
**Three Quad High Panel****FPC3/FPI3/INK-33090****Trim Size:**  $29^{7/16}''_W \times 89^{3/4}''_H / 747_W \times 2280\text{mm}_H$ **Stiffener Punch (Top/Bottom):** Notched/Plain**Required Stiffeners (Top/Bottom):** GSCLT, GSCLB**Three Quad High Reduced Quad Classic Panel****FPC3R/INK-32490****Trim Size:**  $23^{7/32}''_W \times 70^{3/4}''_H / 590_W \times 1797\text{mm}_H$ **Stiffener Punch (Top/Bottom):** Notched/Plain**Required Stiffeners (Top/Bottom):** GSCLTR, GSCLBR**Three Quad High Bubble Panel****YFPU3CC35/INK-33590C****Trim Size:**  $35''_W \times 89^{3/4}''_H / 889_W \times 1797\text{mm}_H$ **Stiffener Punch (Top/Bottom):** Notched/Plain**Required Stiffeners (Top/Bottom):** YGSBPHT, YGSBPHB

Name

Equivalent Fabric/Graphic Code

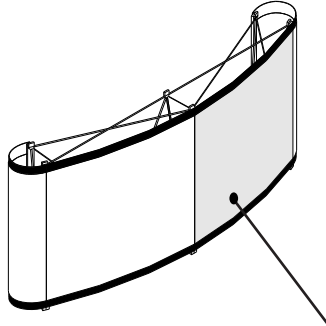
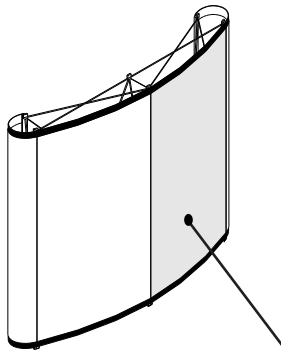
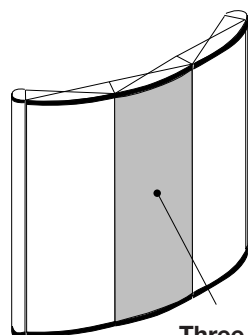
**One Quad High Classic Back Panel****FPC1B/INK-13230**One Quad High  
Classic Back Panel**Trim Size:** 32 <sup>1</sup>/<sub>2</sub>"<sub>W</sub> x 28<sup>3</sup>/<sub>16</sub>"<sub>H</sub> / 825<sub>W</sub> x 716mm<sub>H</sub>**Stiffener Punch (Top/Bottom):** Notched/Plain**Required Stiffeners (Top/Bottom):** GSCLTB, GSCLBB**Two Quad High Classic Back Panel****FPC2B/INK-23260**Two Quad High  
Classic Back Panel**Trim Size:** 32 <sup>1</sup>/<sub>2</sub>"<sub>W</sub> x 59"<sub>H</sub> / 825<sub>W</sub> x 1500mm<sub>H</sub>**Stiffener Punch (Top/Bottom):** Notched/Plain**Required Stiffeners (Top/Bottom):** GSCLTB, GSCLBB**Three Quad High Classic Back Panel****FPC3B/INK33290**Three Quad High  
Classic Back Panel**Trim Size:** 32 <sup>1</sup>/<sub>2</sub>"<sub>W</sub> x 89<sup>3</sup>/<sub>4</sub>"<sub>H</sub> / 825<sub>W</sub> x 2280mm<sub>H</sub>**Stiffener Punch (Top/Bottom):** Notched/Plain**Required Stiffeners (Top/Bottom):** GSCLTB, GSCLBB

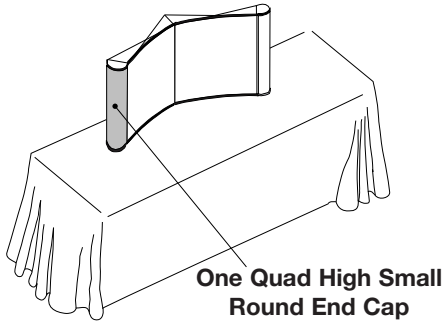
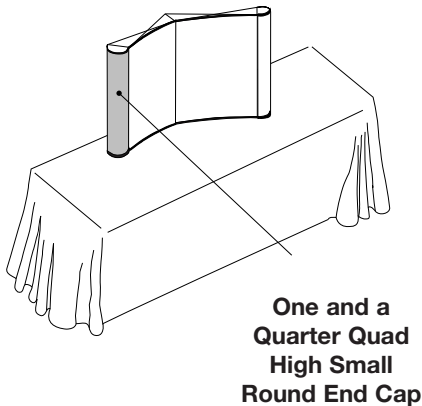
**Name****Equivalent Fabric/Graphic Code****One Quad High Small Round End Cap****FEU1SR/INK-11530****Trim Size:** 15" <sub>W</sub> x 28 <sup>3/16</sup>" <sub>H</sub> / 381 <sub>W</sub> x 716mm <sub>H</sub>**Stiffener Punch (Top/Bottom):** Notched/Plain**Required Stiffeners:** GSSRT, GSSRB**One and a Quarter Quad High Small Round End Cap** **FEU1HSR/INK-11540****Trim Size:** 15" <sub>W</sub> x 38 <sup>1/4</sup>" <sub>H</sub> / 381 <sub>W</sub> x 972mm <sub>H</sub>**Stiffener Punch (Top/Bottom):** Notched/Plain**Required Stiffeners:** GSSRT, GSSRB

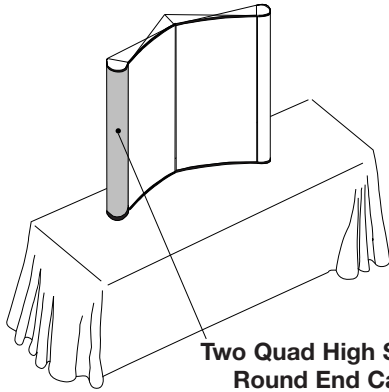
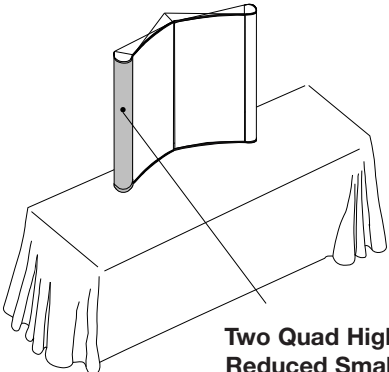
**Name****Equivalent Fabric/Graphic Code****Two Quad High Small Round End Cap****FEU2SR/INK-215060**Two Quad High Small  
Round End Cap**Trim Size:** 15" <sub>W</sub> x 59" <sub>H</sub> / 381<sub>W</sub> x 1500mm<sub>H</sub>**Stiffener Punch (Top/Bottom):** Notched/Plain**Required Stiffeners:** GSSRT, GSSRB**Two Quad High Reduced Quad Small Round End Cap****FEU2RSR/INK-21547**Two Quad High  
Reduced Small  
Round End Cap**Trim Size:** 12" <sub>W</sub> x 46 <sup>11/32</sup>" <sub>H</sub> / 305<sub>W</sub> x 1177mm<sub>H</sub>**Stiffener Punch (Top/Bottom):** Notched/Plain**Required Stiffeners:** YGSSRRT, YGSSRRB

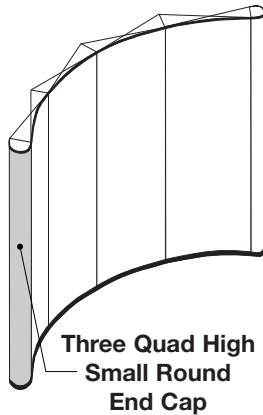
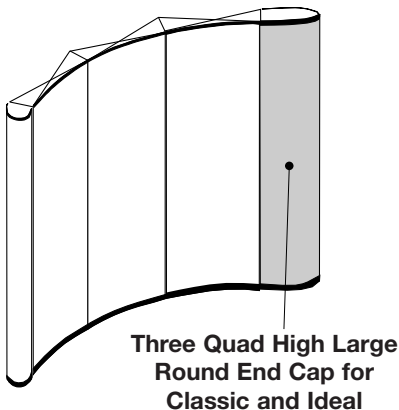
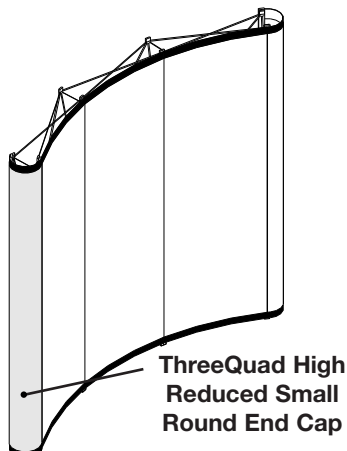
**Name****Equivalent Fabric/Graphic Code****Three Quad High Small Round End Cap****FEU3SR/INK-31590****Trim Size:** 15" <sub>W</sub> x 89 <sup>3/4</sup>" <sub>H</sub> / 381<sub>W</sub> x 2280<sub>mmH</sub>**Stiffener Punch (Top/Bottom):** Notched/Plain**Required Stiffeners:** GSSRT, GSSRB**Three Quad High Large Round End Cap** **FEC3LR/FEI3LR/INK-31590E****Trim Size:** 29 <sup>7/16</sup>" <sub>W</sub> x 89 <sup>3/4</sup>" <sub>H</sub> / 747<sub>W</sub> x 2280<sub>mmH</sub>**Stiffener Punch (Top/Bottom):** Notched/Plain**Required Stiffeners:** YGESDT, YGESDB**Three Quad High Reduced Quad Small Round End Cap** **FEU3SRR/INK-33190E****Trim Size:** 12" <sub>W</sub> x 70 <sup>3/4</sup>" <sub>H</sub> / 305<sub>W</sub> x 1797<sub>mmH</sub>**Stiffener Punch (Top/Bottom):** Notched/Plain**Required Stiffeners:** YGSSRRT, YGSSRRB



Name

Equivalent Fabric/Graphic Code

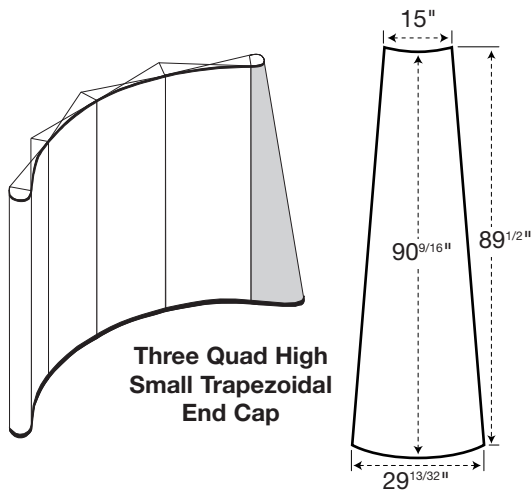
**Three Quad High Small Trapezoidal End Cap**
**FEU3T/INK-33090T**

Three Quad High  
Small Trapezoidal  
End Cap

**Trim Size:** 15" <sub>W(top)</sub> x 29<sup>13/32</sup>" <sub>W(bottom)</sub> x 89<sup>3/4</sup>" <sub>H(sides)</sub> x  
90<sup>9/16</sup>" <sub>H(center)</sub> / 381mm <sub>W(top)</sub> x 747mm <sub>W(bottom)</sub>  
x 2280mm <sub>H(sides)</sub> x 2300mm <sub>H(center)</sub>

**Stiffener Punch (Top/Bottom):** Special

**Required Stiffeners:** YGSTT, YGSTB

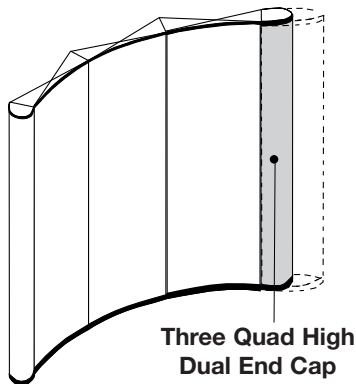
**Three Quad High Dual End Cap**
**FEU3DU/INK-33090D**

Three Quad High  
Dual End Cap

**Trim Size:** 29<sup>7/16</sup>" <sub>W</sub> x 89<sup>3/4</sup>" <sub>H</sub> / 747 <sub>W</sub> x 2280mm <sub>H</sub>

**Stiffener Punch (Top/Bottom):** Notched/Plain (special: 2  
center holes 14<sup>1/2</sup>" / 368mm from each side)

**Required Stiffeners:** YGESDT, YGESDB

## **Instructions for Mounting HINGED Graphic Panels on Nomadic Instand (Classic)**

Nomadic recommends that you order the appropriate magnetic mounting materials to produce *HINGED* strips and panels. Please refer to the Graphics Production Materials page in the Accessories section of your green Nomadic Display Answer Book I.

### **Before you begin**

Read through these instructions and refer to the Graphic Specification Table for *HINGED* strip and panel trim dimensions.

It is recommended that you set up your Instand frame so that your completed graphic panels can be hung and checked. If necessary, stiffeners and magnetic tape can be removed and relocated before the adhesive fully sets.

### **Step 1 - Lay Down the Strip**

Mark the score line for each hinge width on the graphic panel. Slit the panel along the score line. See Figure 1. Place the graphic panel (trimmed to exact dimensions from the Specifications Table) face down on a protected surface. Temporarily tape the middle and end of the slit with masking tape.

### **Step 2 - Affix the *HINGING* Tape**

Affix the *HINGING* tape at the end without masking tape. Work toward the opposite end of the panel removing the temporary masking tape as you reach it. Apply pressure to the *HINGING* tape using a squeegee or a roller. The adhesive is pressure activated so this is a critical step.

### **Step 3 - Affix the Adhesive Tape**

Lay the double backed tape down along the full width of the strip at the top and bottom edges. Press firmly on backing to affix tape to the graphic strip. Remove the backing to expose the tape's upper layer of adhesive. See Figure 2.

### **Step 4 - Attach Stiffeners**

Place the bottom 1" / 25mm of the stiffener on the exposed adhesive tape. Be sure to use notched or punched stiffeners at the top of the strip. Take care to center the stiffener onto the end of the strip. Once the stiffener is correctly aligned press it firmly into place along its entire length. A roller is recommended to ensure a uniform bond. Follow the same steps to attach the bottom stiffener. Use a straight edge to bend the stiffeners at the score line.

### **Step 5 - Lay Down the Magnetic Tape**

Apply the magnetic tape  $1/16"$  / 1.5mm from the outer edge of the strip. Peel off the protective backing on the adhesive side of the tape as you unroll and lay it from the bottom edge of the top stiffener to the top edge of the bottom stiffener. Again, a roller is recommended to ensure a uniform bond. See Figure 3.

### **Step 6 - Check Finished Panels**

Be sure your measurements are correct. Stiffeners will extend  $1^{1/2}"$  / 39mm from each end of the graphic panel. Magnetic tape will be about  $1/16"$  / 1.5mm from the outer edge of the panel. There should be no gaps between adjacent panels. Inspect the panels promptly by hanging them on your Instand frame. Adjustments can be made before the adhesive sets.

### **Warning —**

**This kit is made available exclusively to authorized dealers of Nomadic Instand. Nomadic Display assumes no responsibility for damage to graphic strips or panels in the use of this kit. Using these materials with products other than the Nomadic Instand magnetic mounting system may not result in a high quality display.**

**Nomadic Display has made every effort to ensure that the enclosed specifications are completely accurate. However, these dimensions should serve as guidelines only. In order to achieve a genuinely precise fit, IT IS STRONGLY RECOMMENDED that test panels be created using scrap materials, prior to creating final graphic panels.**

### Example of Hinge Width

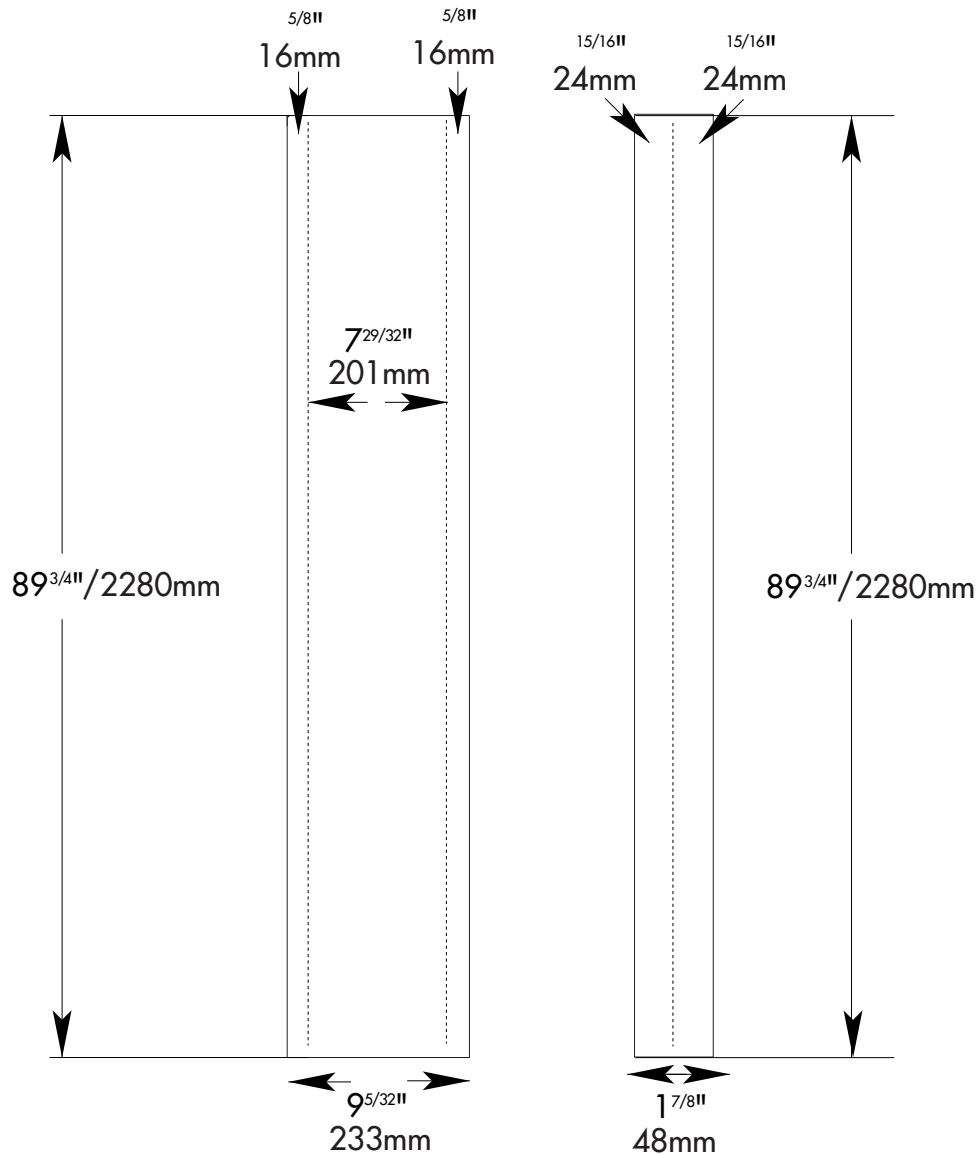
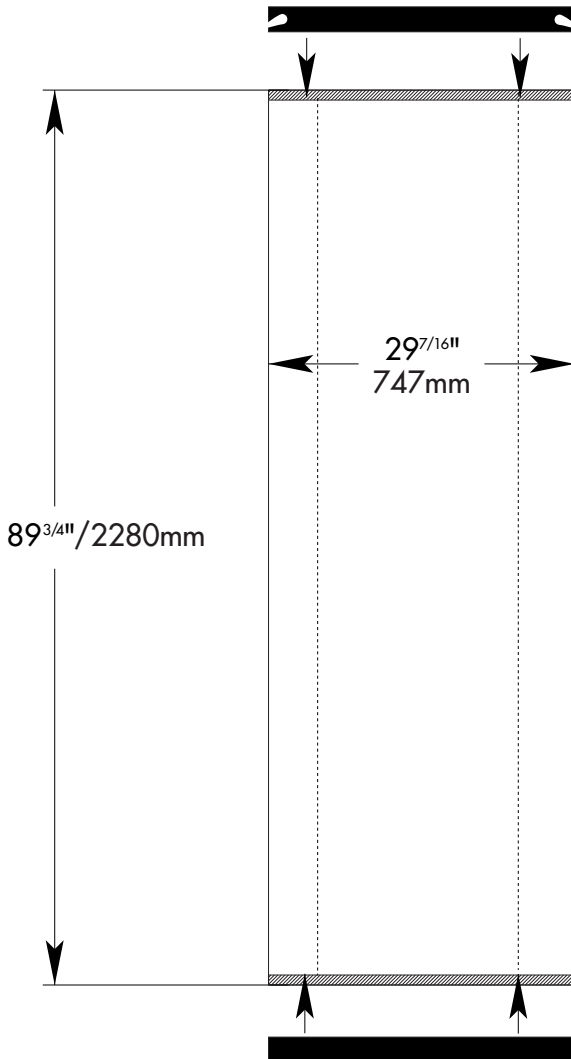

Fig. 1

## Example of Stiffener and Magnet Mounting



**Fig. 2**

Apply 1" / 25mm double backed adhesive tape to top and bottom

Attach top and bottom stiffeners

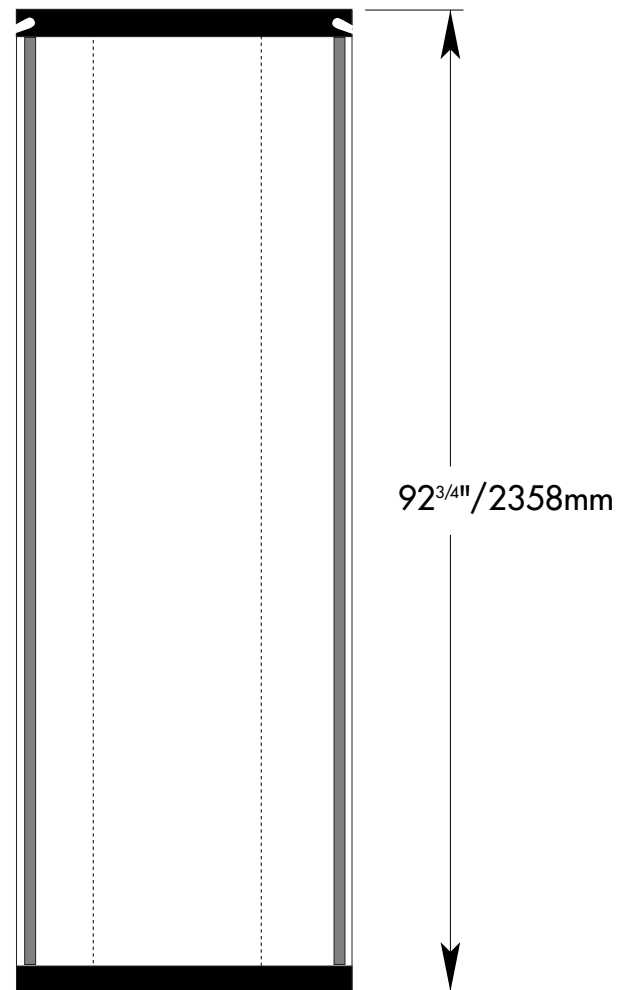

**Fig. 3**

Apply magnetic tape 1/16" / 1.5mm from outer edges

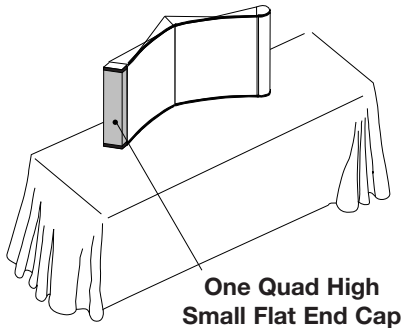
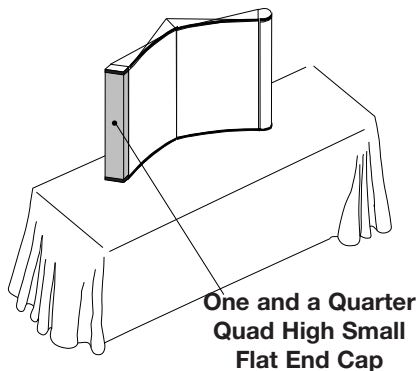
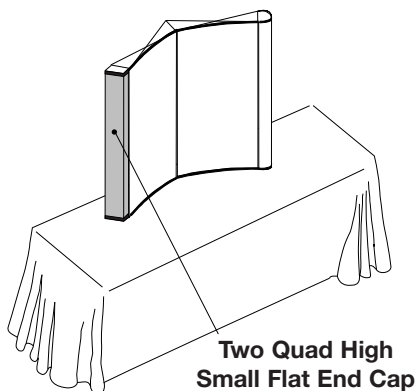
**Name****Equivalent Fabric/Graphic Code****One Quad High Small Flat End Cap****FEU1SF/INK-11030****Trim Size:**  $9^{5/32}''_W \times 28^{11/32}''_H / 233_W \times 720\text{mm}_H$ **Hinge Specifications:**  $5/8'' + 7^{29/32}'' + 5/8'' / 16 + 201 + 16\text{mm}$ **Aluminum Bars (Top/Bottom):** Yes/Yes**Stiffener Punch (Top/Bottom):** Notched/Plain**Required Stiffeners (Top/Bottom):** GSSFT, GSSFB**One and a Quarter Quad High Small Flat End Cap****FEU1HSF/INK-11040****Trim Size:**  $9^{5/32}''_W \times 38^{1/4}''_H / 233_W \times 972\text{mm}_H$ **Hinge Specifications:**  $5/8'' + 7^{29/32}'' + 5/8'' / 16 + 201 + 16\text{mm}$ **Aluminum Bars (Top/Bottom):** Yes/Yes**Stiffener Punch (Top/Bottom):** Notched/Plain**Required Stiffeners (Top/Bottom):** GSSFT, GSSFB**Two Quad High Small Flat End Cap****FEU2SF/INK-21060****Trim Size:**  $9^{5/32}''_W \times 59''_H / 233_W \times 1500\text{mm}_H$ **Hinge Specifications:**  $5/8'' + 7^{29/32}'' + 5/8'' / 16 + 201 + 16\text{mm}$ **Aluminum Bars (Top/Bottom):** Yes/Yes**Stiffener Punch (Top/Bottom):** Notched/Plain**Required Stiffeners (Top/Bottom):** GSSFT, GSSFB

Name

Equivalent Fabric/Graphic Code

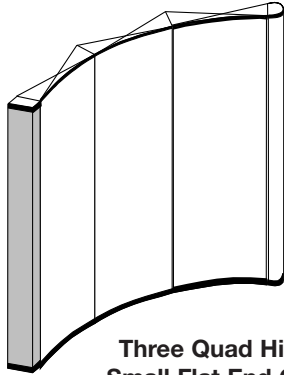
**Three Quad High Small Flat End Cap**
**FEU3SF/INK-31090**

**Three Quad High  
Small Flat End Cap**
**Trim Size:**  $9^{5/32}''_W \times 89^{3/4}''_H$  /  $233_W \times 2280\text{mm}_H$ 
**Hinge Specifications:**  $^{5/8}'' + 7^{29/32}'' + ^{5/8}''$  /  $16 + 201 + 16\text{mm}$ 
**Aluminum Bars (Top/Bottom):** Yes/Yes

**Stiffener Punch (Top/Bottom):** Notched/Plain

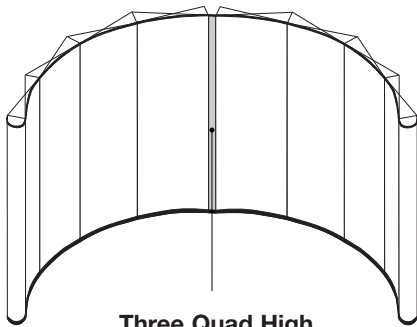
**Required Stiffeners (Top/Bottom):** GSSFT, GSSFB

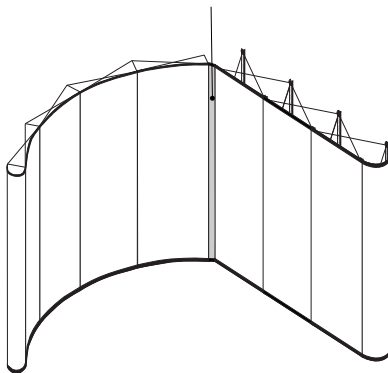
**Three Quad High Hinged Filler Panel**
**FPF3SH/INK-3290**

**Three Quad High  
Hinged Filler Panel**
**Trim Size:**  $1^{7/8}''_W \times 89^{3/4}''_H$  /  $48_W \times 2280\text{mm}_H$ 
**Hinge Widths:**  $^{15/16}'' : ^{15/16}''$  /  $24\text{mm} : 24\text{mm}$ 
**Stiffener Punch (Top/Bottom):** Oval/Plain

**Required Stiffeners (Top/Bottom):** GSHFT, GSHFB

## Instructions for Mounting Graphic Panels on Nomadic Instand (Plus)

Nomadic recommends that you order the appropriate magnetic mounting materials to produce strips and panels. Please refer to the Graphics Production Materials page in the Accessories section of your green Nomadic Display Answer Book I.

### Before you begin

Read through these instructions and refer to the Graphic Specification Table for strip and panel trim dimensions. It is recommended that you set up your Instand frame so that your completed graphic panels can be hung and checked. If necessary, stiffeners and magnetic tape can be removed and relocated before the adhesive fully sets.

### Step 1 - Lay Down the Strip

Place the graphic panel (trimmed to exact dimensions from the Specifications Table) face down on a protected surface.

### Step 2 - Affix the Adhesive Tape

Lay the double-backed tape down along the full width of the graphic at the top and bottom edges. Press firmly on backing to affix tape to the graphic strip. Remove the backing to expose the tape's upper layer of adhesive. See Figure 1.

### Step 3 - Attach Stiffeners and/or Loop Tape

The matte surface of the stiffener should be seen on the front of the display. Place the bottom 1" / 25mm of the stiffener on the exposed adhesive tape (glossy side up). Be sure to use notched or punched stiffeners at the top of the strip. Take care to center the stiffener onto the end of the strip. Once the stiffener is correctly aligned press it firmly into place along its entire length. A roller is recommended to ensure a uniform bond. Follow the same steps to attach the bottom stiffener. NOTE: End cap stiffeners are thinner .015" / .3mm thick.

### Step 4 - Lay Down the Magnetic Tape

Apply the magnetic tape  $\frac{1}{16}$ " / 1.5mm from the outer edge of the graphic. Peel off the protective backing on the adhesive side of the tape as you unroll and lay it from the bottom edge of the top stiffener to the top edge of the bottom stiffener. Again, a roller is recommended to ensure a uniform bond. See Figure 2.



## Step 5 - Attach Aluminum Bars

When aluminum bars are necessary, remove paper backing to expose adhesive on the aluminum bar. Center the bar on the top of panel directly onto the top stiffener and press into place. Repeat process and apply to the bottom of panel directly onto the bottom stiffener. See Figure 4. NOTE: Do not place aluminum bars on graphics that curve. See the Specification Table for bar requirements.

## Step 6 - Check Finished Panels

Be sure your measurements are correct. Stiffeners will extend  $1\frac{1}{2}$ " / 39mm from each end of the graphic panel with the matte surface showing. Magnetic tape will be about  $\frac{1}{16}$ " / 1.5mm from the outer edge of the panel. There should be no gaps between adjacent panels. Inspect the panels promptly by hanging them on your Instand frame. Adjustments can be made before the adhesive sets. See Figure 3.

For light box transparency mounting see Figure 4.

## Warning —

**This kit is made available exclusively to authorized dealers of Nomadic Instand. Nomadic Display assumes no responsibility for damage to graphic strips or panels in the use of this kit. Using these materials with products other than the Nomadic Instand magnetic mounting system may not result in a high quality display.**

**Nomadic Display has made every effort to ensure that the enclosed specifications are completely accurate. However, these dimensions should serve as guidelines only. In order to achieve a genuinely precise fit, IT IS STRONGLY RECOMMENDED that test panels be created using scrap materials, prior to creating final graphic panels.**

## Example of Stiffener and Magnet Mounting

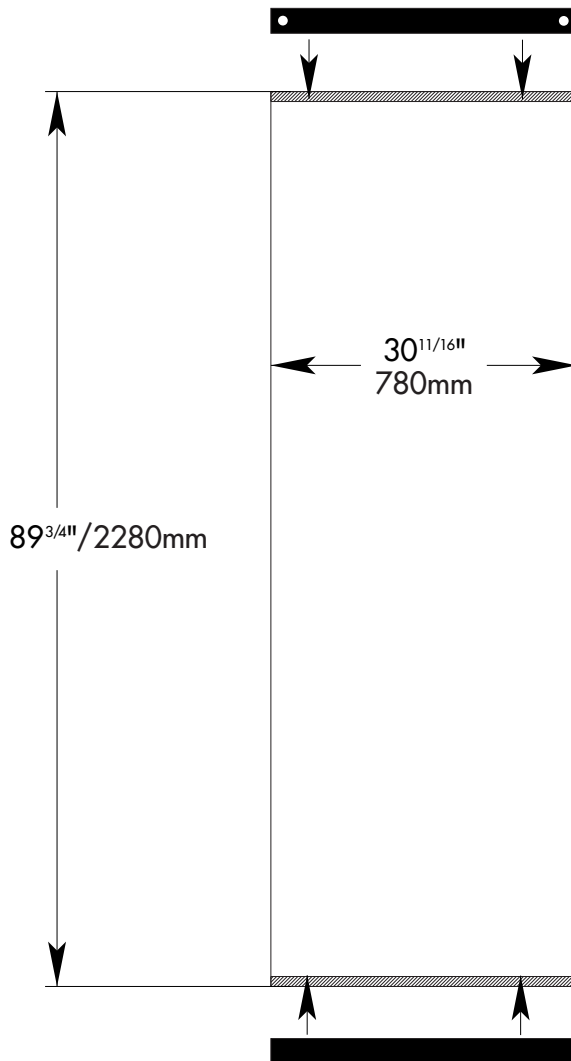

**Fig. 1**

Apply 1" / 25mm double backed adhesive tape to top and bottom

Attach top and bottom stiffeners

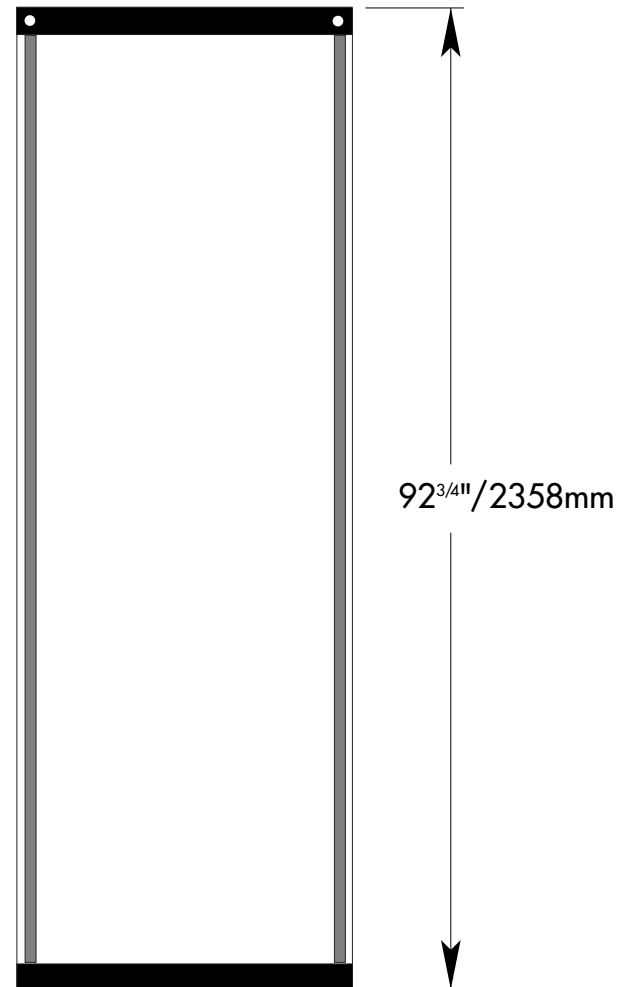

**Fig. 2**

Apply magnetic tape 1/16" / 1.5mm from outer edges

### Example of Aluminum Bar Mounting

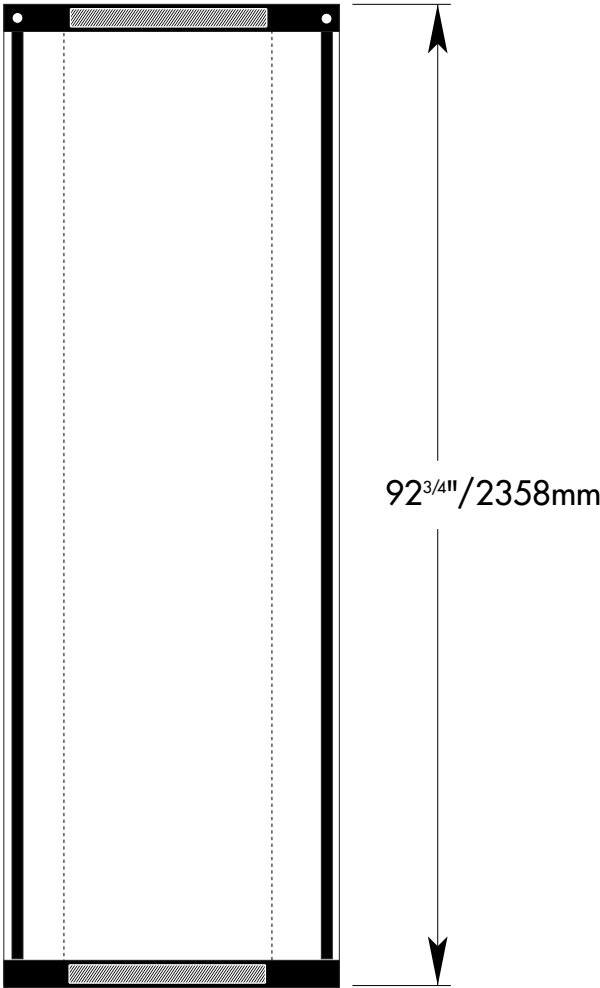

**Fig. 3**  
Attach aluminum bars to top and bottom

## Example of Light Box Transparency Panel Mounting

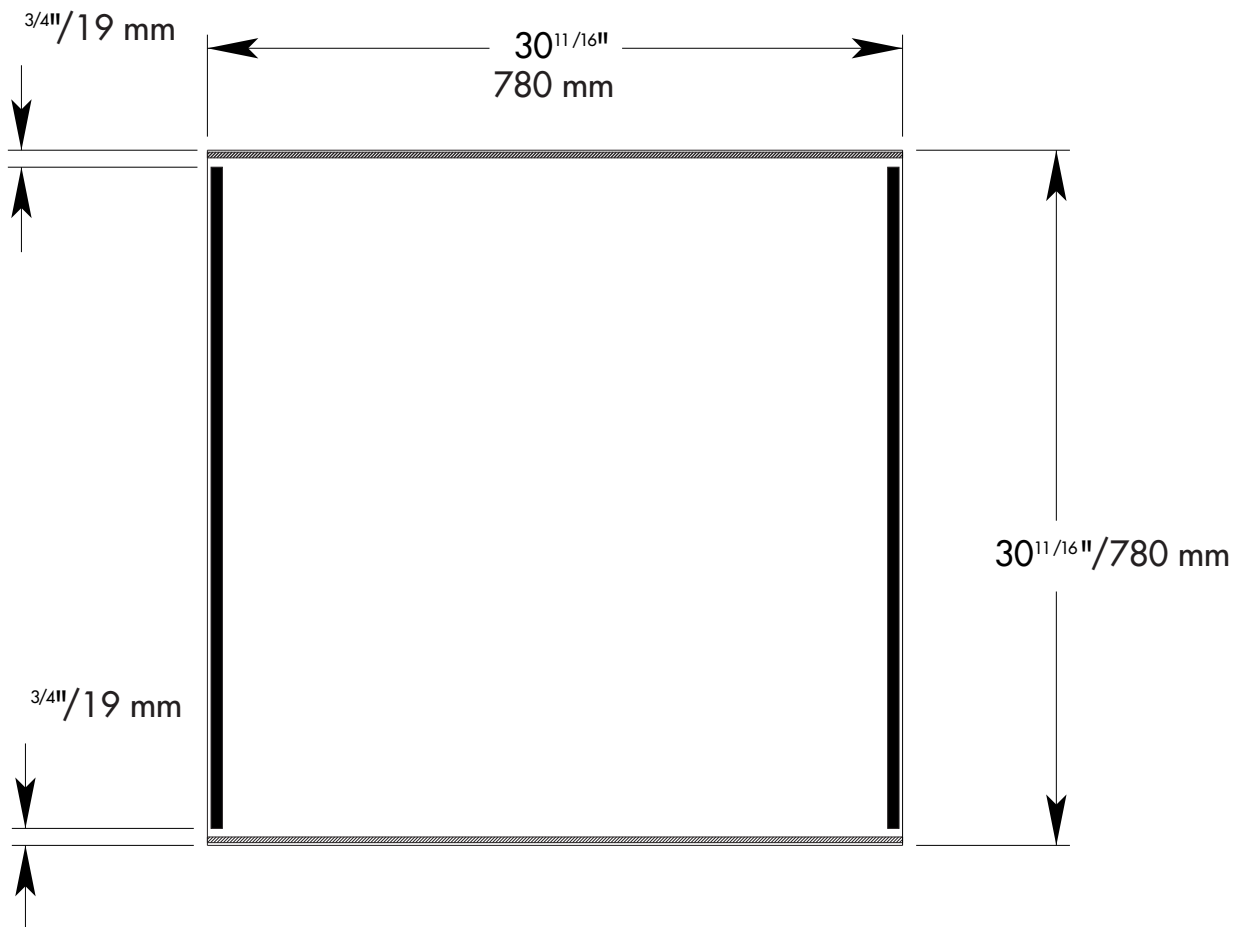
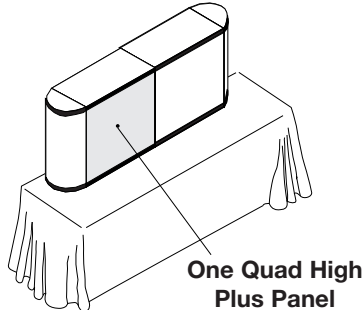
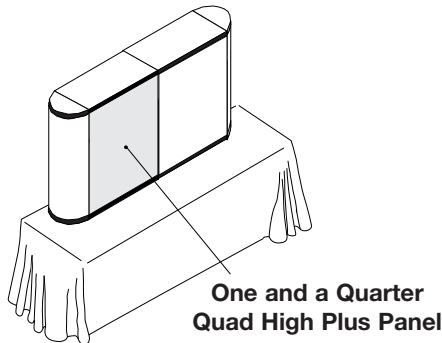
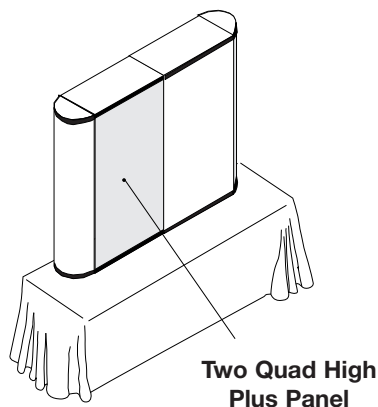

**Fig. 4**

Apply  $\frac{1}{4}$ " / 6mm hook Velcro® to top and bottom  
Apply  $\frac{1}{2}$ " / 12mm magnetic tape  $\frac{1}{16}$ " / 1.5mm from outer edges

Name

Equivalent Fabric/Graphic Code

**One Quad High Plus Panel****FPP1/INK-P13030****Trim Size:**  $30^{11/16}{}_W \times 28^{3/16}{}_H / 780_W \times 716\text{mm}_H$ **Aluminum Bars (Top/Bottom):** Yes / Yes —  $27^{1/4} / 692\text{mm}$ **Aluminum Bar Code:** GSAT (x2)**Stiffener Punch (Top/Bottom):** Oval/Plain**Required Stiffeners (Top/Bottom):** GSPLT, GSPLB**One and a Quarter Quad High Plus Panel****FPP11H/INK-P11640****Trim Size:**  $30^{11/16}{}_W \times 38^{1/4}{}_H / 780_W \times 972\text{mm}_H$ **Aluminum Bars (Top/Bottom):** Yes / Yes —  $27^{1/4} / 692\text{mm}$ **Aluminum Bar Code:** GSAT (x2)**Stiffener Punch (Top/Bottom):** Oval/Plain**Required Stiffeners (Top/Bottom):** GSPLT, GSPLB**Two Quad High Plus Panel****FPP2/INK-P23160****Trim Size:**  $30^{11/16}{}_W \times 59{}_H / 780_W \times 1500\text{mm}_H$ **Aluminum Bars (Top/Bottom):** Yes / Yes —  $27^{1/4} / 692\text{mm}$ **Aluminum Bar Code:** GSAT (x2)**Stiffener Punch (Top/Bottom):** Oval/Plain**Required Stiffeners (Top/Bottom):** GSPLT, GSPLB

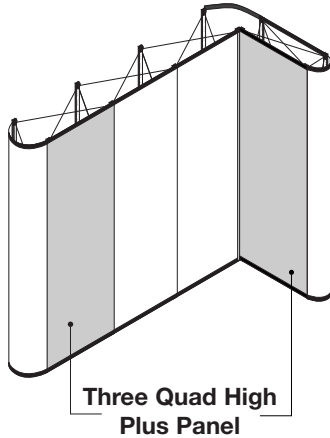
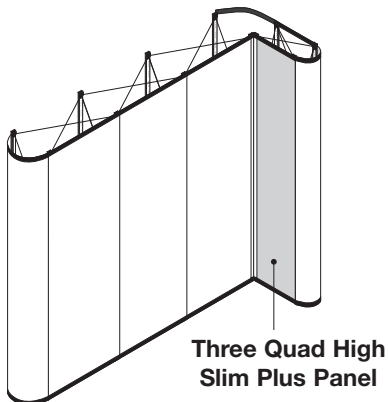
**Name****Equivalent Fabric/Graphic Code****Three Quad High Plus Panel****FPP3/INK-33190****Trim Size:**  $30^{11/16}{}_W \times 89^{3/4}{}_H$  /  $780{}_W \times 2280\text{mm}_H$ **Aluminum Bars (Top/Bottom):** Yes / Yes —  $27^{1/4}{}_W$  /  $692\text{mm}_H$ **Aluminum Bar Code:** GSAT (x2)**Stiffener Punch (Top/Bottom):** Oval/Plain**Required Stiffeners (Top/Bottom):** GSPLT, GSPLB**Three Quad High Slim Plus Panel****FPP3SL/INK-P31690S****Trim Size:**  $15^{11/32}{}_W \times 89^{3/4}{}_H$  /  $390{}_W \times 2280\text{mm}_H$ **Aluminum Bars (Top/Bottom):** Yes / Yes —  $11^{13/16}{}_W$  /  $300\text{mm}_H$ **Aluminum Bar Code:** GSATLF (x2)**Stiffener Punch (Top/Bottom):** Oval/Plain**Required Stiffeners (Top/Bottom):** GSPLT, GSPLB

Name

Equivalent Fabric/Graphic Code

## Three Quad High Small Quarter Round Plus Panel

**FPP3SQ/INK-32090**

Three Quad High  
Small Quarter Round  
Plus Panel

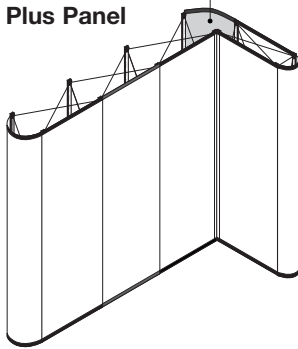

**Trim Size:**  $19\frac{1}{2}''_W \times 89\frac{3}{4}''_H$  /  $495_W \times 2280_{mm}_H$

**Stiffener Punch (Top/Bottom):** Notched/Plain

**Required Stiffeners (Top/Bottom):** GSSQT, GSSQB

## Three Quad High Medium Quarter Round Plus Panel

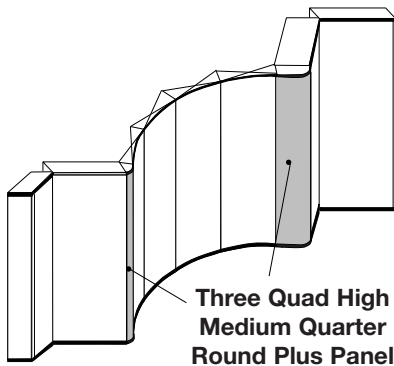
**FPP3MQ/INK-P32390**

Three Quad High  
Medium Quarter  
Round Plus Panel

**Trim Size:**  $22\frac{1}{2}''_W \times 89\frac{3}{4}''_H$  /  $571_W \times 2280_{mm}_H$

**Stiffener Punch (Top/Bottom):** Notched/Plain

**Required Stiffeners (Top/Bottom):** YGSLQRT, YGSLQRB

## Three Quad High Large Quarter Round Plus Panel

**FPP3LQ/INK-32590**

Three Quad High  
Large Quarter Round  
Plus Panel

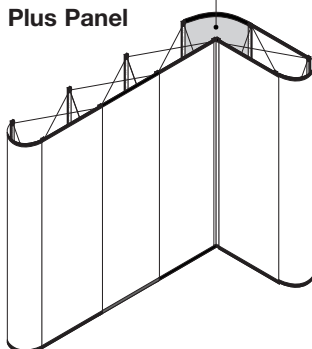

**Trim Size:**  $25''_W \times 89\frac{3}{4}''_H$  /  $635_W \times 2280_{mm}_H$

**Stiffener Punch (Top/Bottom):** Notched/Plain

**Required Stiffeners (Top/Bottom):** GSLQRT, GSLQRB

Name

Equivalent Fabric/Graphic Code

### Four Quad High Plus Panel

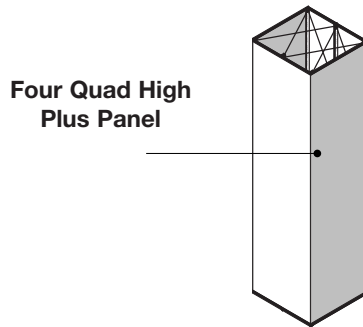
**FPP4/INK-P431120**

**Trim Size:**  $30^{11/16}''_W \times 120^{1/2}''_H / 780_W \times 3060\text{mm}_H$ 
**Aluminum Bars (Top/Bottom):** Yes / Yes —  $27^{1/4}'' / 692\text{mm}$ 
**Aluminum Bar Code:** GSAT (x2)

**Stiffener Punch (Top/Bottom):** Oval/Plain

**Required Stiffeners (Top/Bottom):** GSPLT, GSPLB

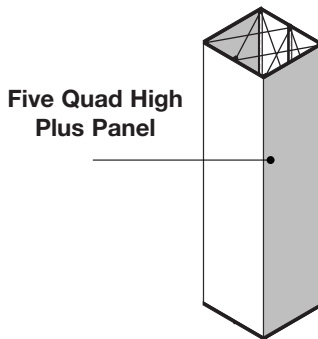
### Five Quad High Plus Panel

**FPP5/INK-P531151**

**Trim Size:**  $30^{11/16}''_W \times 151^{1/4}''_H / 780_W \times 3840\text{mm}_H$ 
**Aluminum Bars (Top/Bottom):** Yes/Yes -  $27^{1/4}'' / 692\text{mm}$ 
**Aluminum Bar Code:** GSAT (x2)

**Stiffener Punch (Top/Bottom):** Oval/Plain

**Required Stiffeners (Top/Bottom):** GSPLT, GSPLB

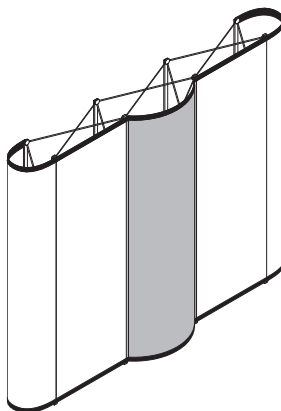
### Three Quad High Large Bubble Panel

**YFPU3CC35/INK-33590C**

**Trim Size:**  $35''_W \times 89^{3/4}''_H / 889_W \times 2280\text{mm}_H$ 
**Hinge Specifications:**  $1'' + 0.24'' + 32.56'' + 0.24'' + 1'' / 25 + 6 + 827 + 6 + 25\text{mm}$ 
**Aluminum Bars (Top/Bottom):** None

**Stiffener Punch (Top/Bottom):** Notched/Plain

**Required Stiffeners (Top/Bottom):** GSBPHT, GSBPHB



Name

Equivalent Fabric Code

## Top Quad Plus Panel

**FPPT**

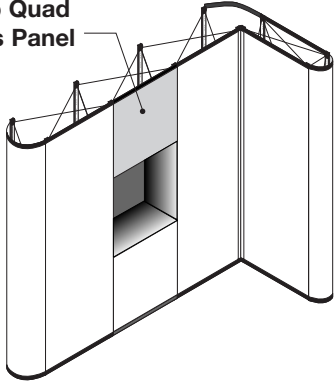
 Top Quad  
Plus Panel
 

**Trim Size:**  $30^{11/16}''_W \times 30''_H / 780_W \times 762\text{mm}_H$ 
**Image Area :**  $30^{11/16}''_W \times 29^{1/2}''_H / 780_W \times 750\text{mm}_H$ 
**Aluminum Bars (Top/Bottom):** Yes / Yes —  $27^{1/4}'' / 692\text{mm}$ 
**Aluminum Bar Code:** GSAT (x2)

**Stiffener Punch (Top/Bottom):** Oval/None

**Required Stiffeners (Top/Bottom):** GSPLT

NOTE: Aluminum bar to be placed 25mm from bottom edge of panel.

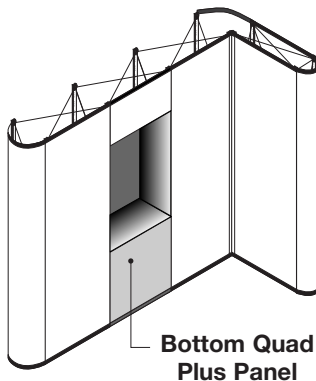
## Bottom Quad Plus Panel

**FPPB**

 Bottom Quad  
Plus Panel

**Trim Size:**  $30^{11/16}''_W \times 30''_H / 780_W \times 762\text{mm}_H$ 
**Image Area :**  $30^{11/16}''_W \times 29^{10/32}''_H / 780_W \times 745\text{mm}_H$ 
**Aluminum Bars (Top/Bottom):** Yes / Yes —  $27^{1/4}'' / 692\text{mm}$ 
**Aluminum Bar Code:** GSAT (x2)

**Stiffener Punch (Top/Bottom):** None/Plain

**Required Stiffeners (Top/Bottom):** GSPLB

NOTE: Aluminum bar to be placed 25mm from bottom edge of panel.

## Bottom Two Quad Plus Panel

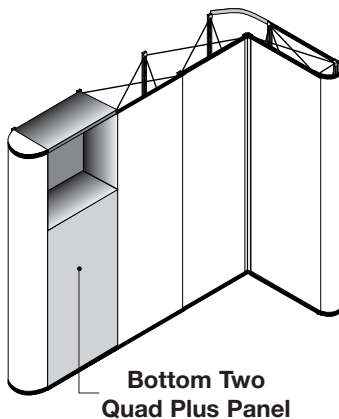
**FPPB2**

 Bottom Two  
Quad Plus Panel

**Trim Size:**  $30^{11/16}''_W \times 60^{1/2}''_H / 780_W \times 1542\text{mm}_H$ 
**Stiffener Punch (Top/Bottom):** None/Plain

**Required Stiffeners:** GSPLB

NOTE: Aluminum bar to be placed 25mm from bottom edge of panel.

Name

Equivalent Fabric Code

**Top Half Quad Plus ShowCase Panel**
**FPPTSC**

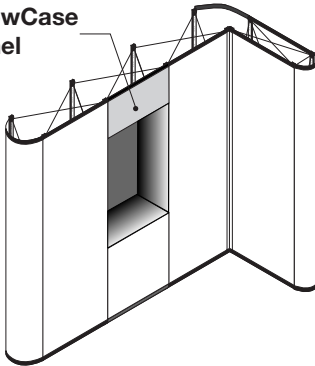
 Top Half Quad  
Plus ShowCase  
Panel

**Trim Size:**  $30^{11/16}{}_W \times 15^{3/4}{}_H$  /  $780_W \times 400\text{mm}_H$ 
**Image Area :**  $30^{11/16}{}_W \times 14^{7/8}{}_H$  /  $780_W \times 378\text{mm}_H$ 
**Aluminum Bars (Top/Bottom):** Yes / Yes —  $27^{1/4}"/692\text{mm}$ 
**Aluminum Bar Code:** GSAT (x2)

**Stiffener Punch (Top/Bottom):** Oval/None

**Required Stiffeners:** GSPLT

NOTE: Aluminum bar to be placed 25mm from bottom edge of panel.

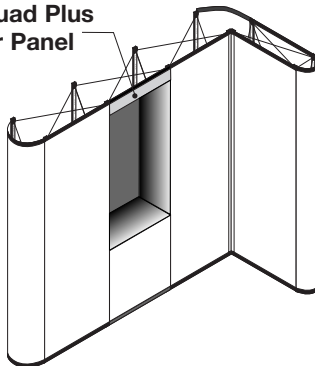
**Top Quad Plus Filler Panel**
**FPFT**

 Top Quad Plus  
Filler Panel

**Trim Size:**  $30^{11/16}{}_W \times 3^{1/2}{}_H$  /  $780_W \times 89\text{mm}_H$ 
**Image Area :**  $30^{11/16}{}_W \times 3{}_H$  /  $780_W \times 75\text{mm}_H$ 
**Aluminum Bars (Top/Bottom):** Yes / Yes —  $27^{1/4}"/692\text{mm}$ 
**Aluminum Bar Code:** GSAT (x2)

**Stiffener Punch (Top/Bottom):** Oval/None

**Required Stiffeners:** GSPLT

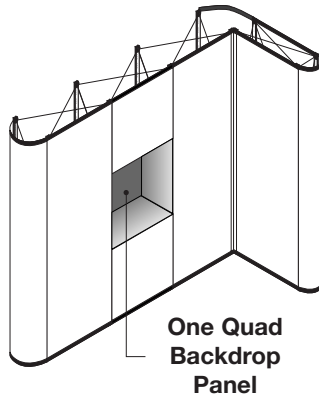
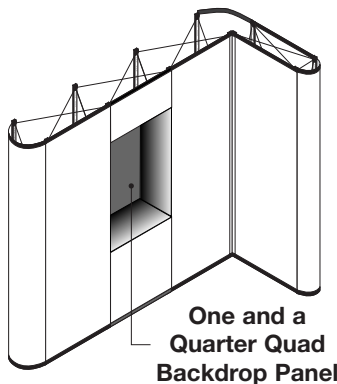
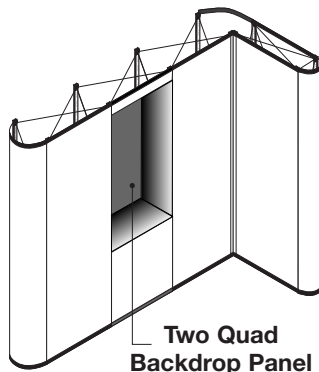
NOTE: Aluminum bar to be placed 25mm from bottom edge of panel.

**Name****Equivalent Fabric Code****One Quad Backdrop Panel****FPU1B****Trim Size:**  $30^{11/16}''_W \times 30^{11/16}''_H / 780_W \times 780\text{mm}_H$ **Velcro® Loop (All Sides):** Yes**One and a Quarter Quad Backdrop Panel****FPU1HB****Trim Size:**  $30^{11/16}''_W \times 45^{1/4}''_H / 780_W \times 1149\text{mm}_H$ **Velcro® Loop (All Sides):** Yes**Two Quad Backdrop Panel****FPU2B****Trim Size:**  $30^{11/16}''_W \times 57^{1/2}''_H / 780_W \times 1460\text{mm}_H$ **Velcro® Loop (All Sides):** Yes

Name

Equivalent Fabric Code

## Plus Transparency Panel

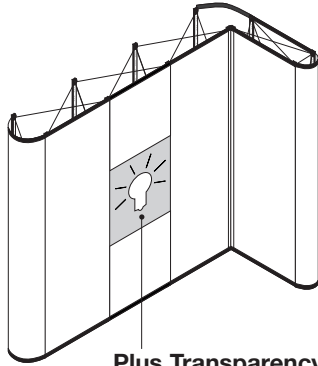
**NA**

Plus Transparency Panel

**Trim Size:**  $30^{11/16}{}_W \times 30^{11/16}{}_H / 780_W \times 780_{mm}_H$ 
**Velcro® hook (Top/Bottom):** Yes / Yes

**Live Image Area:**  $29^{3/16}{}_W \times 29^{3/16}{}_H / 742_W \times 742_{mm}_H$ 

## Top Quad Plus Eye Level Light Box Panel

**FPPTLBE**

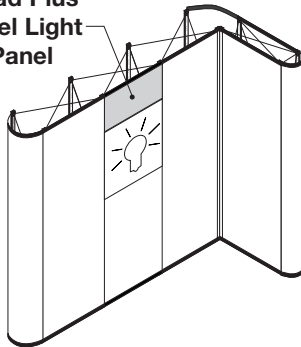
 Top Quad Plus  
Eye Level Light  
Box Panel

**Trim Size:**  $30^{11/16}{}_W \times 15{}_H / 780_W \times 381_{mm}_H$ 
**Aluminum Bars (Top/Bottom):** Yes / Yes —  $27^{1/4} / 692_{mm}$ 
**Aluminum Bar Code:** GSAT (x2)

**Stiffener Punch (Top/Bottom):** Oval / None

**Required Stiffeners:** GSPLT

NOTE: Aluminum bar to be placed 25mm from bottom edge of panel.

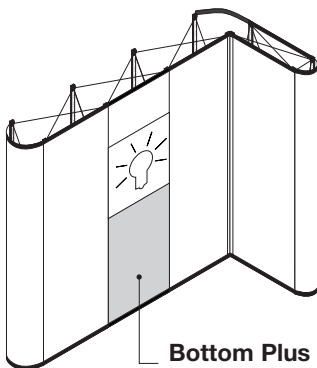
## Bottom Plus Eye Level Light Box Panel

**FPPBLBE**

 Bottom Plus Eye  
Level Light Box Panel

**Trim Size:**  $30^{11/16}{}_W \times 45{}_H / 780_W \times 1143_{mm}_H$ 
**Aluminum Bars (Top/Bottom):** Yes / Yes —  $27^{1/4} / 692_{mm}$ 
**Aluminum Bar Code:** GSAT (x2)

**Stiffener Punch (Top/Bottom):** None/Plain

**Required Stiffeners:** GSPLT

NOTE: Aluminum bar to be placed 25mm from bottom edge of panel.

Name

Equivalent Fabric Code

## One Quad High Extended Quad Plus Panel

**FPP1E**

One Quad High  
Extended Quad  
Plus Panel

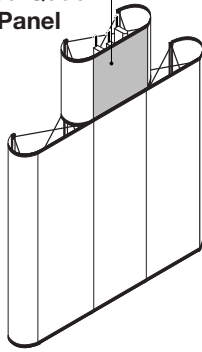

**Trim Size:**  $30^{11/16}''_W \times 29^{1/8}''_H / 780_W \times 740\text{mm}_H$

**Aluminum Bars (Top/Bottom):** Yes / Yes —  $27^{1/4}''/692\text{mm}$

**Aluminum Bar Code:** GSAT (x2)

**Stiffener Punch (Top/Bottom):** Oval/Special

**Live Image Area:**  $29^{3/16}''_W \times 27^{1/8}''_H / 742_W \times 689\text{mm}_H$

**Required Stiffeners:** GSPLT

## One Quad High Large Round Extended Quad End Cap

**FEU1RE**

One Quad High  
Large Round  
Extended Quad  
End Cap

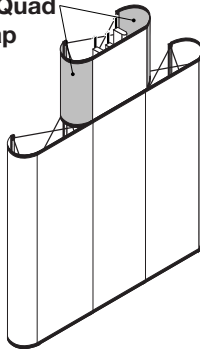

**Trim Size:**  $30^{11/16}''_W \times 29^{1/8}''_H / 780_W \times 740\text{mm}_H$

**Stiffener Punch (Top/Bottom):** Notched/Special

**Required Stiffeners (Top/Bottom):** GSLRT, GSLRB

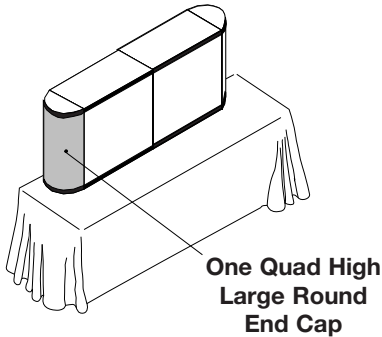
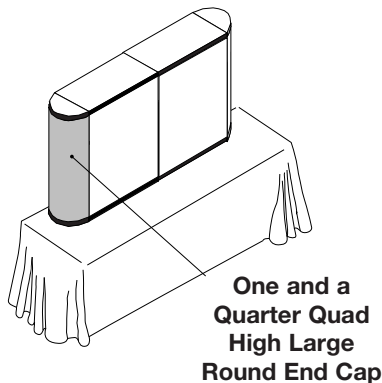
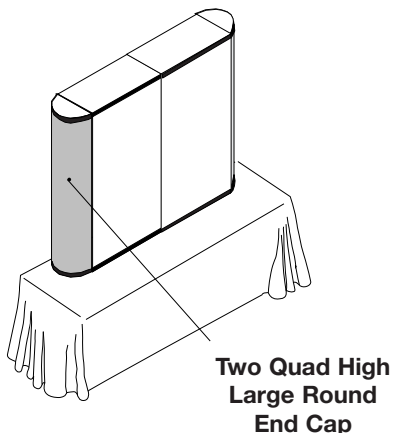
**Name****Equivalent Fabric/Graphic Code****One Quad High Large Round End Cap****FEU1LR/INK-13030E****Trim Size:**  $30^{11/16}''_W \times 28^{3/16}''_H / 780_W \times 716\text{mm}_H$ **Stiffener Punch (Top/Bottom):** Notched/Plain**Required Stiffeners (Top/Bottom):** GSLRT, GSLRB**One and a Quarter Quad High Large Round End Cap** **FEU1HLR/INK-13040E****Trim Size:**  $30^{11/16}''_W \times 38^{1/4}''_H / 780_W \times 972\text{mm}_H$ **Stiffener Punch (Top/Bottom):** Notched/Plain**Required Stiffeners (Top/Bottom):** GSLRT, GSLRB**Two Quad High Large Round End Cap****FEU2LR/INK-23060E****Trim Size:**  $30^{11/16}''_W \times 59''_H / 780_W \times 1500\text{mm}_H$ **Stiffener Punch (Top/Bottom):** Notched/Plain**Required Stiffeners (Top/Bottom):** GSLRT, GSLRB

Name

Equivalent Fabric/Graphic Code

**Three Quad High Small Round End Cap**

**FEU3SR/INK-31590**

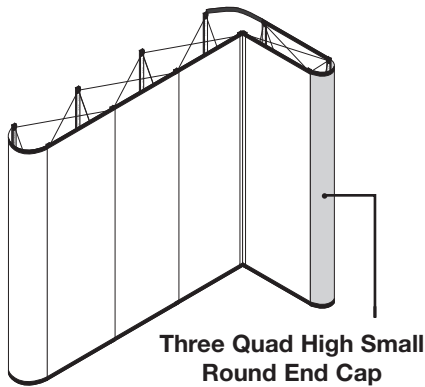

**Trim Size:** 15" <sub>W</sub> x 89 <sup>3/4</sup>" <sub>H</sub> / 381 <sub>W</sub> x 2280 <sub>H</sub>

**Stiffener Punch (Top/Bottom):** Notched/Plain

**Required Stiffeners (Top/Bottom):** GSSRT, GSSRB

**Three Quad High Plus Large Round End Cap**

**FEP3LR/INK-P33190E**

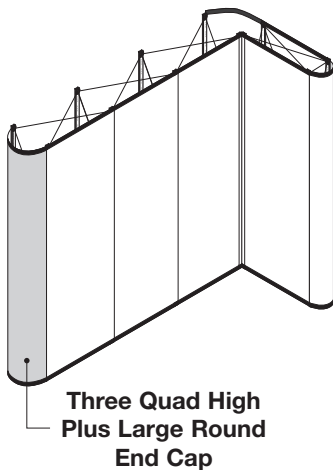

**Trim Size:** 30 <sup>11/16</sup>" <sub>W</sub> x 89 <sup>3/4</sup>" <sub>H</sub> / 780 <sub>W</sub> x 2280 <sub>H</sub>

**Stiffener Punch (Top/Bottom):** Notched/Plain

**Required Stiffeners (Top/Bottom):** GSLRT, GSLRB

**Three Quad High Small Trapezoidal End Cap**

**FEU3T/INK-33090T**

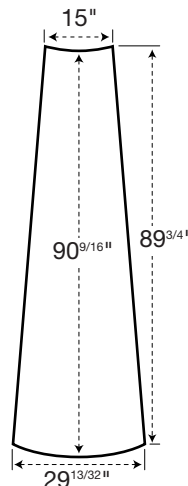
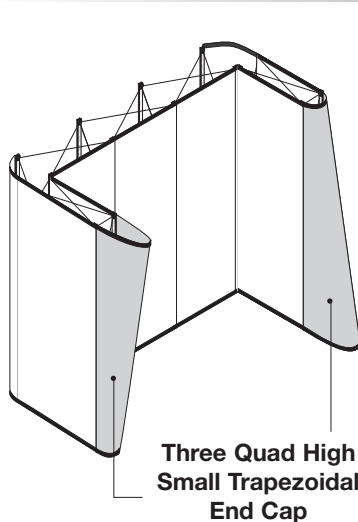

**Trim Size:** 15" <sub>W(top)</sub> x 29 <sup>13/32</sup>" <sub>W(bottom)</sub> x 89 <sup>3/4</sup>" <sub>H(sides)</sub> x 90 <sup>9/16</sup>" <sub>H(center)</sub> / 381 <sub>W(top)</sub> x 747 <sub>W(bottom)</sub> x 2280 <sub>H(sides)</sub> x 2300 <sub>H(center)</sub>

**Stiffener Punch (Top/Bottom):** Special

**Required Stiffeners (Top/Bottom):** YGSTT, YGSTB

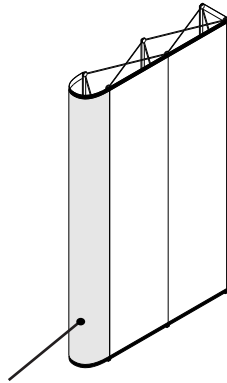
**Name****Equivalent Fabric/Graphic Code****Four Quad High Plus Large Round End Cap****FEP4LR/INK-P431 120E**

**Four Quad High  
Plus Large Round  
End Cap**

**Trim Size:**  $30^{11/16}{}_W \times 120^{1/2}{}_H$  /  $780_W \times 3060\text{mm}_H$

**Stiffener Punch (Top/Bottom):** Notched/Plain

**Required Stiffeners (Top/Bottom):** GSLRT, GSLRB



## **Instructions for Mounting HINGED Graphic Panels on Nomadic Instand (Plus)**

Nomadic recommends that you order the appropriate magnetic mounting materials to produce *HINGED* strips and panels. Please refer to the Graphics Production Materials page in the Accessories section of your green Nomadic Display Answer Book I.

### **Before you begin**

Read through these instructions and refer to the Graphic Specification Table for *HINGED* strip and panel trim dimensions.

It is recommended that you set up your Instand frame so that your completed graphic panels can be hung and checked. If necessary, stiffeners and magnetic tape can be removed and relocated before the adhesive fully sets.

### **Step 1 - Lay Down the Strip**

Mark the score line for each hinge width on the graphic panel. Slit the panel along the score line. See Figure 1. Place the graphic panel (trimmed to exact dimensions from the Specifications Table) face down on a protected surface. Temporarily tape the middle and end of the slit with masking tape.

### **Step 2 - Affix the *HINGING* Tape**

Affix the *HINGING* tape at the end without masking tape. Work toward the opposite end of the panel removing the temporary masking tape as you reach it. Apply pressure to the *HINGING* tape using a squeegee or a roller. The adhesive is pressure activated so this is a critical step.

### **Step 3 - Affix the Adhesive Tape**

Lay the double backed tape down along the full width of the strip at the top and bottom edges. Press firmly on backing to affix tape to the graphic strip. Remove the backing to expose the tape's upper layer of adhesive. See Figure 2.

## Step 4 - Attach Stiffeners

Place the bottom 1" / 25mm of the stiffener on the exposed adhesive tape. Be sure to use notched or punched stiffeners at the top of the strip. Take care to center the stiffener onto the end of the strip. Once the stiffener is correctly aligned press it firmly into place along its entire length. A roller is recommended to ensure a uniform bond. Follow the same steps to attach the bottom stiffener. Use a straight edge to bend the stiffeners at the score line.

## Step 5 - Lay Down the Magnetic Tape

Apply the magnetic tape  $1/16$ " / 1.5mm from the outer edge of the strip. Peel off the protective backing on the adhesive side of the tape as you unroll and lay it from the bottom edge of the top stiffener to the top edge of the bottom stiffener. Again, a roller is recommended to ensure a uniform bond. See Figure 3.

## Step 6 - Attach Aluminum Bars

Remove backing to expose adhesive on the aluminum bar. Center the bar and press into place on the top of panel directly onto the top stiffener. Repeat process and apply to the bottom of panel directly onto the bottom stiffener. See Figure 4. NOTE: Do not place aluminum bars on end caps or other flexible panels. See the Specification Table for bar requirements.

## Step 7 - Check Finished Panels

Be sure your measurements are correct. Stiffeners will extend  $1^{1/2}$ " / 39mm from each end of the graphic panel. Magnetic tape will be about  $1/16$ " / 1.5mm from the outer edge of the panel. There should be no gaps between adjacent panels. Inspect the panels promptly by hanging them on your Instand frame. Adjustments can be made before the adhesive sets. See Figure 4.

## Warning —

**This kit is made available exclusively to authorized dealers of Nomadic Instand. Nomadic Display assumes no responsibility for damage to graphic strips or panels in the use of this kit. Using these materials with products other than the Nomadic Instand magnetic mounting system may not result in a high quality display.**

**Nomadic Display has made every effort to ensure that the enclosed specifications are completely accurate. However, these dimensions should serve as guidelines only. In order to achieve a genuinely precise fit, IT IS STRONGLY RECOMMENDED that test panels be created using scrap materials, prior to creating final graphic panels.**

## Example of Hinge Width

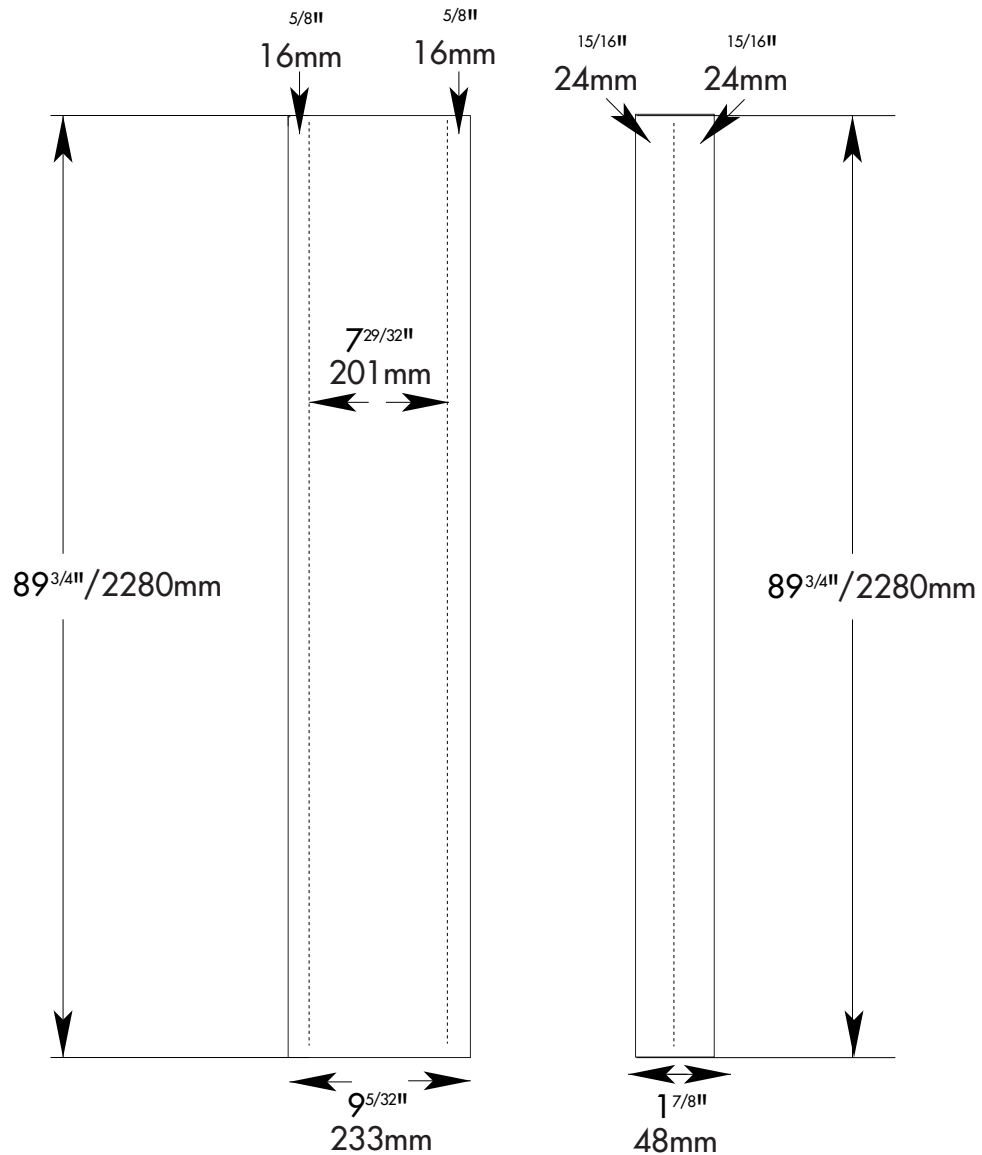
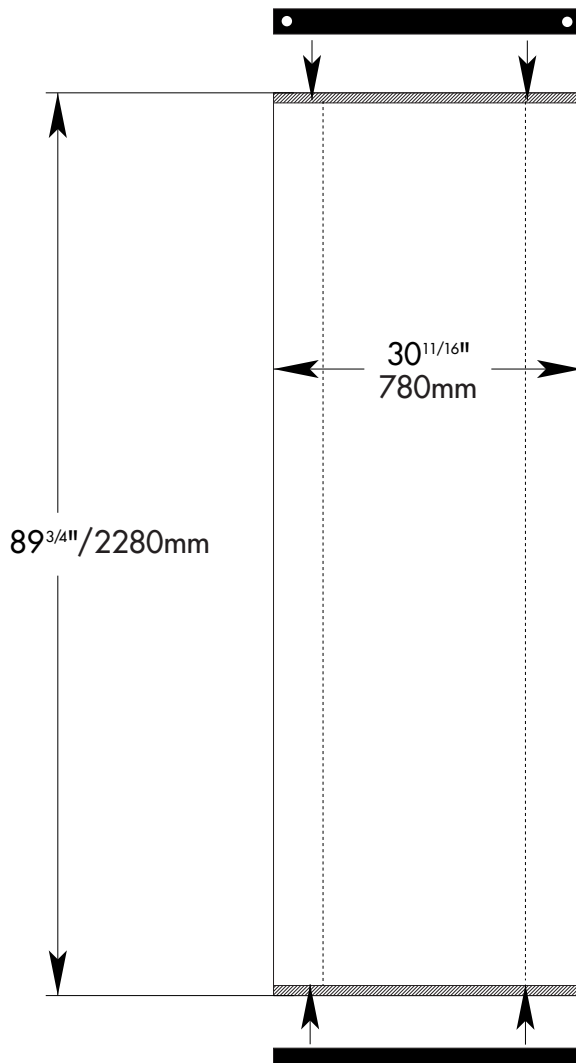

Fig. 1

## Example of Stiffener and Magnet Mounting



**Fig. 2**

Apply 1" / 25mm double backed adhesive tape to top and bottom

Attach top and bottom stiffeners

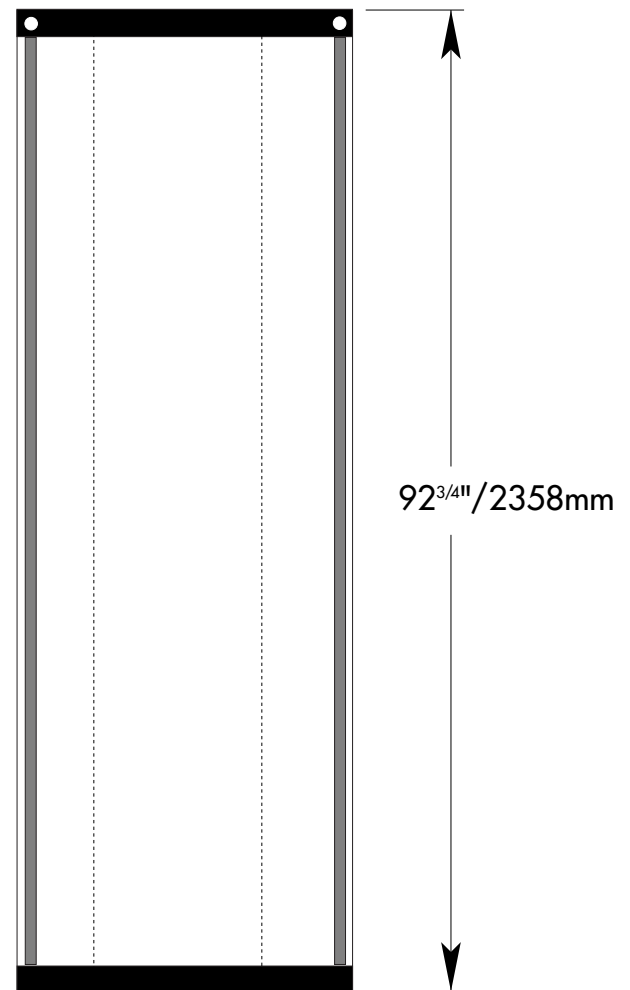

**Fig. 3**

Apply magnetic tape  $1/16$ " / 1.5mm from outer edges

## Example of Aluminum Bar Mounting

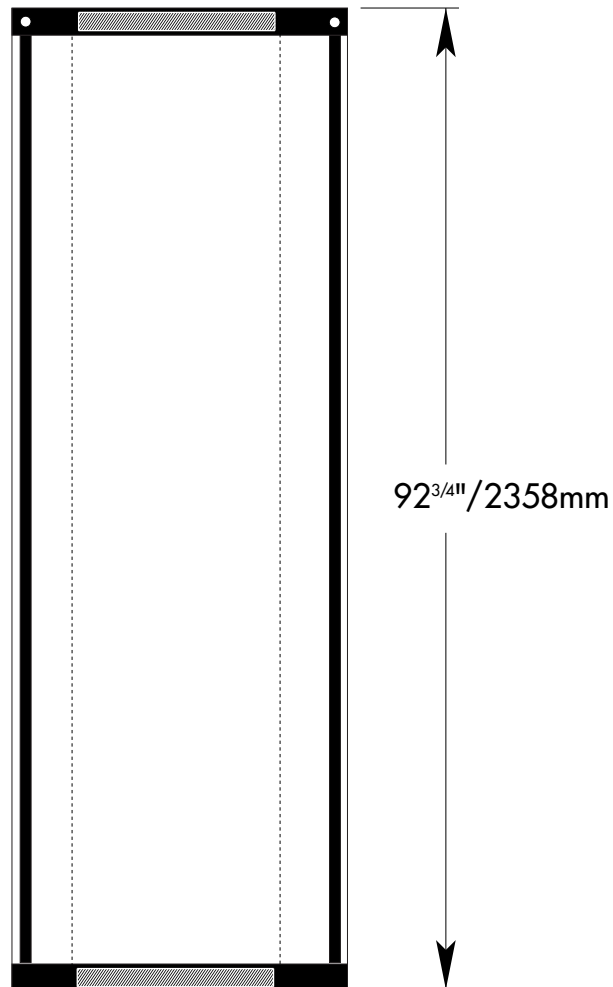

**Fig. 4**

Attach aluminum bars to top and bottom

Name

Equivalent Fabric/Graphic Code

### Three Quad High Double Hinged Panel **FPU3DHM/INK-32090DHM**

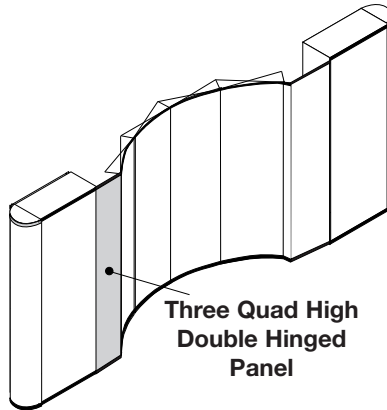

**Trim Size:**  $20^{7/8}''_W \times 89^{3/4}''_H / 530_W \times 2280\text{mm}_H$

**Hinge Width Specification:**  $1'' + 19^{7/8}'' + 1''/25 + 480 + 25\text{mm}$

**Aluminum Bars (Top/Bottom):** Yes / Yes — 17.52"/445mm

**Aluminum Bar Code:** YGSATY17 (x2)

**Stiffener Punch (Top/Bottom):** Notched/Plain Hinged

**Required Stiffeners (Top/Bottom):** YGSPSHRT, YGSPSHRB

### Three Quad High Right Single Hinged Panel **FPU3SHR/INK-32090SH**

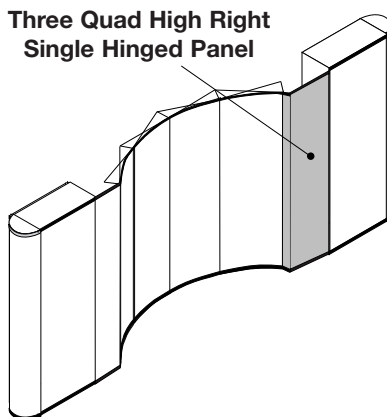

**Trim Size:**  $20^{7/8}''_W \times 89^{3/4}''_H / 530_W \times 2280\text{mm}_H$

**Hinge Width Specification:**  $1'' + 20^{7/8}''/25 + 530\text{mm}$

**Aluminum Bars (Top/Bottom):** Yes / Yes — 17.52"/445mm

**Aluminum Bar Code:** YGSATY17 (x2)

**Stiffener Punch (Top/Bottom):** Notched/Plain Hinged

**Required Stiffeners (Top/Bottom):** YGSPSHRT, YGSPSHRB

### Three Quad High Left Single Hinged Panel **FPU3SHL/INK-32090SHL**

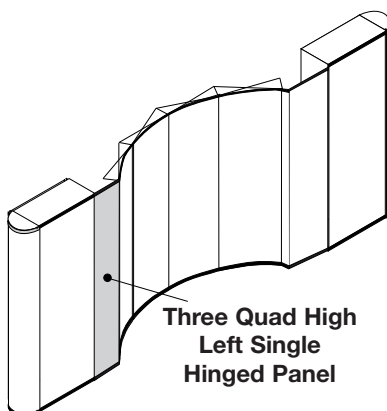

**Trim Size:**  $20^{7/8}''_W \times 89^{3/4}''_H / 530_W \times 2280\text{mm}_H$

**Hinge Width Specification:**  $20^{7/8}'' + 1''/530 + 25\text{mm}$

**Aluminum Bars (Top/Bottom):** Yes / Yes — 17.52"/445mm

**Aluminum Bar Code:** YGSATY17 (x2)

**Stiffener Punch (Top/Bottom):** Notched/Plain Hinged

**Required Stiffeners (Top/Bottom):** YGSPSHRT, YGSPSHRB

Name

Equivalent Fabric/Graphic Code

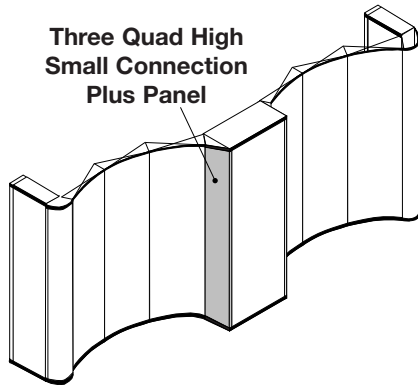
**Three Quad High Small Connection Plus Panel**
**FPP3CS/INK-P31190**

**Trim Size:**  $10^{1/16}''_W \times 89^{3/4}''_H / 255_W \times 2280\text{mm}_H$ 
**Hinge Specifications:**  $1'' + 8^{1/16}'' + 1'' / 25 + 205 + 25\text{mm}$ 
**Aluminum Bars (Top/Bottom):** Yes / Yes —  $17.52''/445\text{mm}$ 
**Aluminum Bar Code:** YGSATY17 (x2)

**Stiffener Punch (Top/Bottom):** Notched/Plain

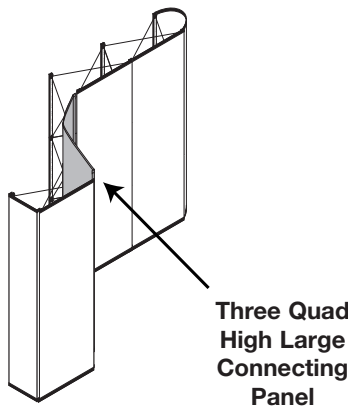
**Required Stiffeners (Top/Bottom):** YGSPCST, YGSPCSB

*Note: This panel is only for use with C33 frames joined to Instand Plus*
**Three Quad High Large Connecting Panel**
**FPU3CL/INK-33190C**

**Trim Size:**  $30^{11/16}''_W \times 89^{3/4}''_H / 780_W \times 2280\text{mm}_H$ 
**Hinge Width Specification:**  $1'' + 28^{11/16}'' + 1'' / 25 + 730 + 25\text{mm}$ 
**Stiffener Punch (Top/Bottom):** Oval/Plain Hinged

**Required Stiffeners (Top/Bottom):** YGSPCST, YGSPCSB

Name

Equivalent Fabric/Graphic Code

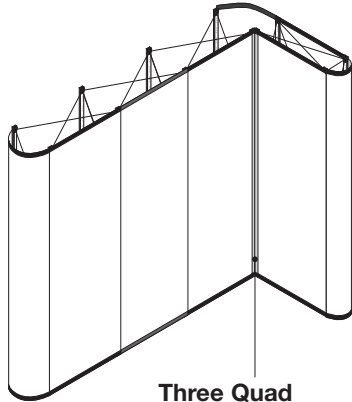
### Three Quad High Hinged Filler Panel

**FPF3SH/INK-3290**

Three Quad  
High Hinged  
Filler Panel

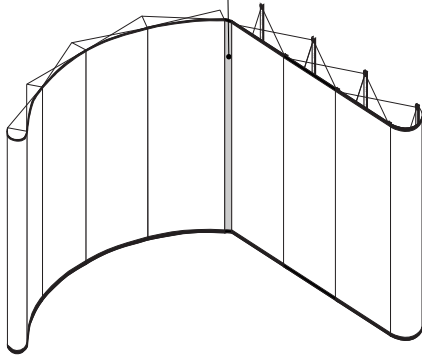
**Trim Size:**  $1\frac{7}{8}''_W \times 89\frac{3}{4}''_H$  /  $48_W \times 2280\text{mm}_H$ 
**Hinge Specifications:**  $\frac{15}{16}'' + \frac{15}{16}''$  /  $24+24\text{mm}$ 
**Stiffener Punch (Top/Bottom):** Oval/Plain

**Required Stiffeners (Top/Bottom):** GSHFT, GSHFB

### Four Quad High Hinged Filler Panel

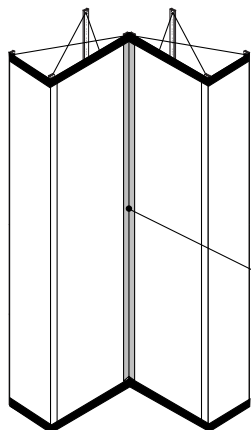
**FPF4SH/INK-42120**

Four Quad  
High Hinged  
Filler Strip

**Trim Size:**  $1\frac{7}{8}''_W \times 120\frac{1}{2}''_H$  /  $48_W \times 3060\text{mm}_H$ 
**Hinge Widths:**  $\frac{15}{16}'' : \frac{15}{16}''$  /  $24\text{mm} : 24\text{mm}$ 
**Stiffener Punch (Top/Bottom):** Oval/Plain

**Required Stiffeners (Top/Bottom):** GSHFT, GSHFB



Name

Equivalent Fabric/Graphic Code

## One Quad High Large Flat End Cap

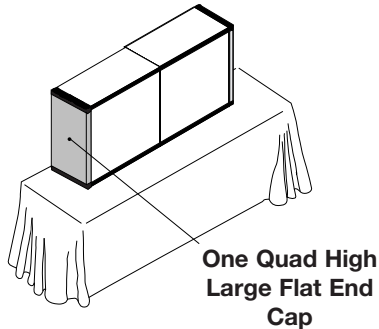
**FEU1LF/INK-11530E**

**Trim Size:**  $15^{23/32}''_W \times 28^{3/16}''_H / 399_W \times 716\text{mm}_H$ 
**Hinge Specifications:**  $1'' + 13^{23/32}'' + 1'' / 25 + 349 + 25\text{mm}$ 
**Aluminum Bars (Top/Bottom):** Yes / Yes —  $11^{13/16}'' / 300\text{mm}$ 
**Aluminum Bar Code:** GSATLF (x2)

**Stiffener Punch (Top/Bottom):** Notched/Plain

**Required Stiffeners (Top/Bottom):** GSLFT, GSLFB

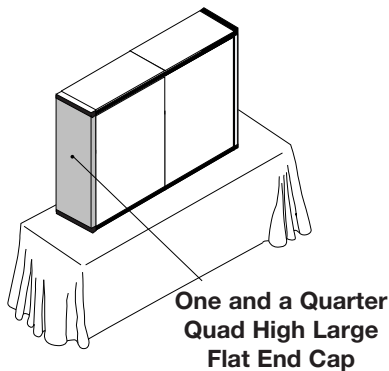
## One and a Quarter Quad High Large Flat End Cap **FEU11HLF/INK-11540E**

**Trim Size:**  $15^{23/32}''_W \times 38^{1/4}''_H / 399_W \times 972\text{mm}_H$ 
**Hinge Specifications:**  $1'' + 13^{23/32}'' + 1'' / 25 + 349 + 25\text{mm}$ 
**Aluminum Bars (Top/Bottom):** Yes / Yes —  $11^{13/16}'' / 300\text{mm}$ 
**Aluminum Bar Code:** GSATLF (x2)

**Stiffener Punch (Top/Bottom):** Notched/Plain

**Required Stiffeners (Top/Bottom):** GSLFT, GSLFB

## Two Quad High Large Flat End Cap **FEU2LF/INK-21560E**

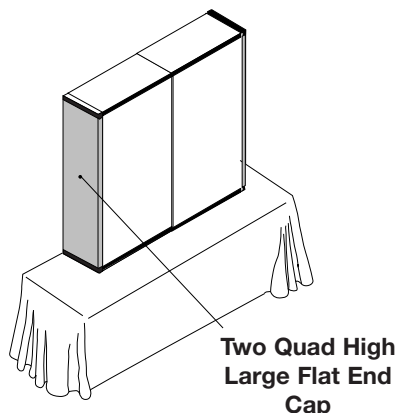
**Trim Size:**  $15^{23/32}''_W \times 59''_H / 399_W \times 1500\text{mm}_H$ 
**Hinge Specifications:**  $1'' + 13^{23/32}'' + 1'' / 25 + 349 + 25\text{mm}$ 
**Aluminum Bars (Top/Bottom):** Yes / Yes —  $11^{13/16}'' / 300\text{mm}$ 
**Aluminum Bar Code:** GSATLF (x2)

**Stiffener Punch (Top/Bottom):** Notched/Plain

**Required Stiffeners (Top/Bottom):** GSLFT, GSLFB

Name

Equivalent Fabric/Graphic Code

## Two Quad High Large Flat Peninsula End Cap

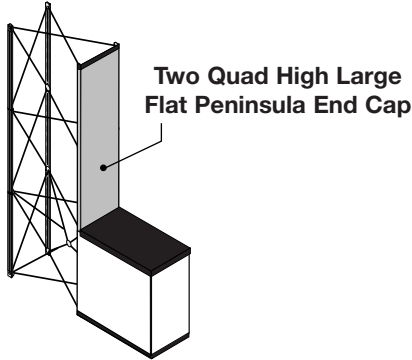
**FEP2LF**

**Trim Size:**  $15^{23/32}''_W \times 59^{1/8}''_H / 399_W \times 1502mm_H$ 
**Hinge Specifications:**  $1'' + 13^{23/32}'' + 1'' / 25 + 349 + 25mm$ 
**Aluminum Bars (Top/Bottom):** Yes / Yes —  $1\ 1^{13/16}'' / 300mm$ 
**Aluminum Bar Code:** GSATLF (x2)

**Stiffener Punch (Top/Bottom):** Notched/None

**Required Stiffeners:** GSLFT

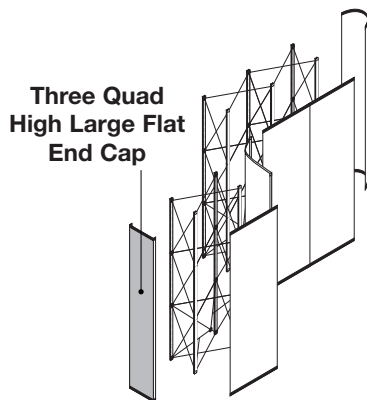
## Three Quad High Large Flat End Cap

**FEU3LF/INK-P31690**

**Trim Size:**  $15^{23/32}''_W \times 89^{3/4}''_H / 399_W \times 2280mm_H$ 
**Hinge Specifications:**  $1'' + 13^{23/32}'' + 1'' / 25 + 349 + 25mm$ 
**Aluminum Bars (Top/Bottom):** Yes / Yes —  $1\ 1^{13/16}'' / 300mm$ 
**Aluminum Bar Code:** GSATLF (x2)

**Stiffener Punch (Top/Bottom):** Notched/Plain

**Required Stiffeners (Top/Bottom):** GSLFT, GSLFB

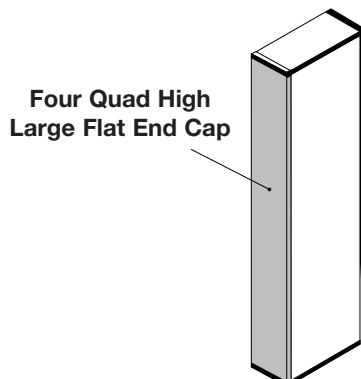
## Four Quad High Large Flat End Cap

**FEU4LF/INK-415120**

**Trim Size:**  $15^{23/32}''_W \times 120^{1/2}''_H / 399_W \times 3060mm_H$ 
**Hinge Specifications:**  $1'' + 13^{23/32}'' + 1'' / 25 + 349 + 25mm$ 
**Aluminum Bars (Top/Bottom):** Yes / Yes —  $1\ 1^{13/16}'' / 300mm$ 
**Aluminum Bar Code:** GSATLF (x2)

**Stiffener Punch (Top/Bottom):** Notched/None

**Required Stiffeners (Top/Bottom):** GSLFT, GSLFB

Name

Equivalent Fabric/Graphic Code

**One Quad High Large Flat Extended Quad End Cap**
**FEU1LFE**

One Quad High  
 Large Flat  
 Extended Quad  
 End Cap

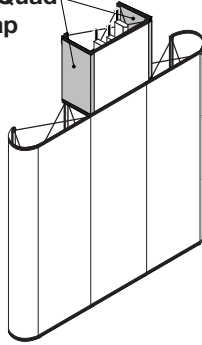

**Trim Size:**  $15^{23/32}''_W \times 29^{1/8}''_H / 399_W \times 740\text{mm}_H$

**Hinge Specifications:**  $1'' + 13^{23/32}'' + 1'' / 25 + 349 + 25\text{mm}$

**Aluminum Bars (Top/Bottom):** Yes / Yes —  $11^{13/16}'' / 300\text{mm}$

**Aluminum Bar Code:** GSATLF (x2)

**Stiffener Punch (Top/Bottom):** Notched/Plain (special)

**Required Stiffeners:** GSLFT

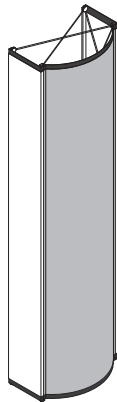
**Four Quad High Bubble Panel**
**YFPU4CC/INK-435120C**

**Trim Size:**  $35''_W \times 120^{1/2}''_H / 889_W \times 3060\text{mm}_H$

**Hinge Specifications:**  $1'' + 0.24'' + 32.56'' + 0.24'' + 1'' / 25 + 6 + 827 + 6 + 25\text{mm}$

**Aluminum Bars (Top/Bottom):** None

**Stiffener Punch (Top/Bottom):** Notched/Plain

**Required Stiffeners (Top/Bottom):** YGSBPHT, YGSBPHB

## Instructions for Mounting Graphic Panels on Bridges

Nomadic recommends that you order the appropriate magnetic mounting materials to produce strips and panels. Please refer to the Graphics Production Materials page in the Accessories section of your green Nomadic Display Answer Book I.

### Before you begin

Read through these instructions and refer to the Graphic Specification Table for standard or hinged strip and panel trim dimensions. It is recommended that you set up your Instand frame so that your completed graphic panels can be hung and checked.

For instructions on mounting standard panels see Instructions for Mounting Graphic Panels on Nomadic Instand Plus page 13.

For instructions on mounting hinged panels see Instructions for Mounting Hinged Graphic Panels on Nomadic Instand Plus page 26.

### Step 1

Beginning from  $1\frac{3}{16}$ "/21mm from the right or left edge of the graphics, carefully apply ØØ magnetic foam backed tape  $\frac{1}{16}$ "/1.5mm from the top edge of the graphics. See Figure 1

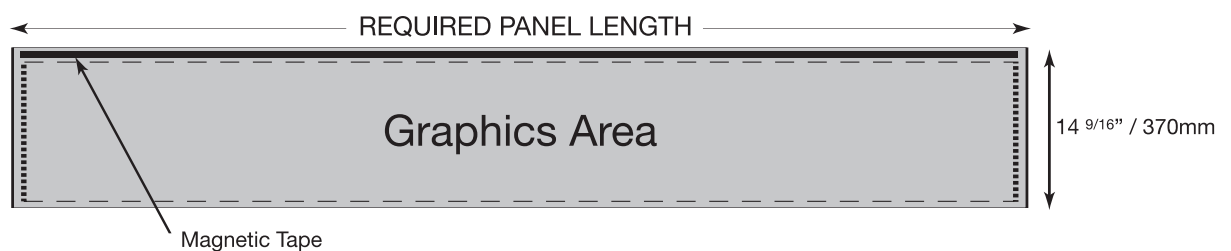

**Fig. 1**

## Step 2

Beginning from  $1\frac{3}{16}$ "/21mm from the right or left edge of the graphics, carefully apply  magnetic foam backed tape  $\frac{1}{16}$ "/1.5mm from the bottom edge of the graphics. See Figure 2.

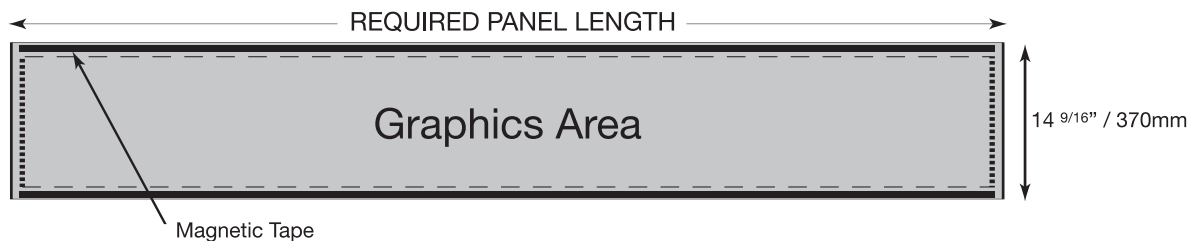

**Fig. 2**

## Step 3

At each end of the Bridge side panel place  $\frac{1}{2}$ "/12.5mm Velcro <sup>®</sup> loop strips  $\frac{1}{16}$ "/1.5mm from each end leaving a  $\frac{9}{16}$ "/14mm gap on the top and bottom. See Figure 3.

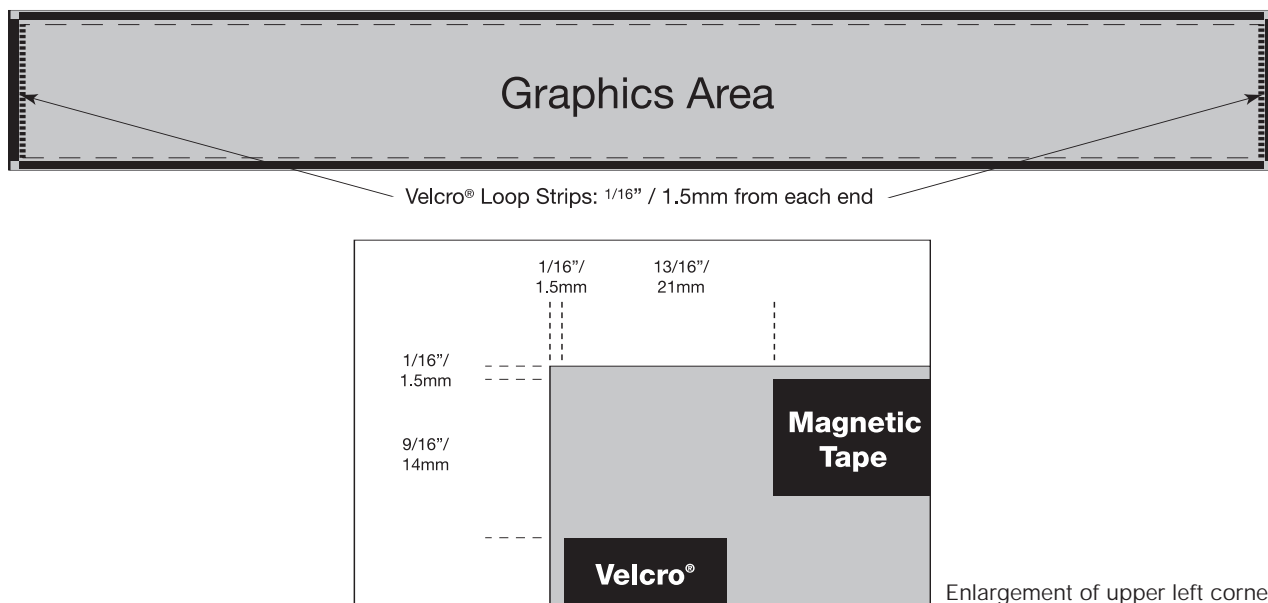

**Fig. 3**

## Panel Lengths:

- 62  $\frac{7}{8}$ " / 1597mm
- 93  $\frac{1}{2}$ " / 2375mm
- 124  $\frac{1}{8}$ " / 3153mm

Name

Equivalent Fabric Code

**63" / 1.6m Bridge Panel (Triangular or Square)**

**FPB63**

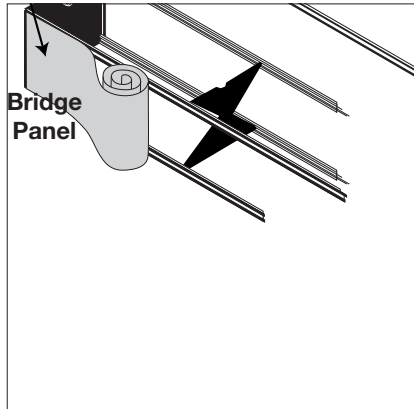

**Trim Size:**  $62^{7/8}''_W \times 14^{9/16}''_H$  /  $1597_W \times 370mm_H$

**Live Image Area:**  $60''_W \times 12^{1/2}''_H$  /  $1524_W \times 318mm_H$

**63" / 1.6m Triangular Bridge Filler Fabric Panel**

**BFPT63**

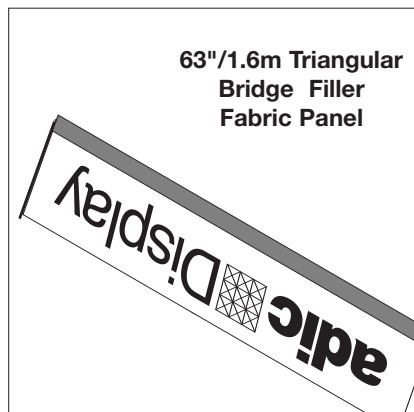

**Trim Size:**  $63''_W \times 1^{5/8}''_H$  /  $1600_W \times 41mm_H$

**Hinge Width Specification :**  $^{13/16}'' + ^{13/16}''$  /  $20^{1/2}mm + 20^{1/2}mm$

**63" / 1.6m Square Bridge Diffuser Panel**

**BDP63**

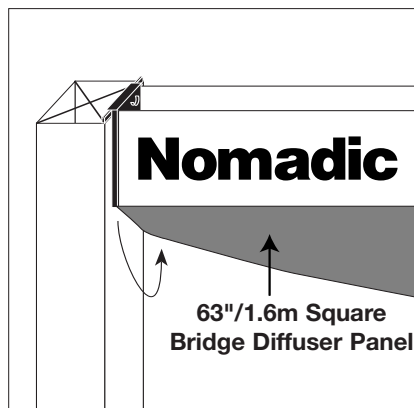

**Trim Size:**  $63''_W \times 12^{11/16}''_H$  /  $1600_W \times 322mm_H$

Nomadic  Instand <sup>®</sup>

Name

Equivalent Fabric Code

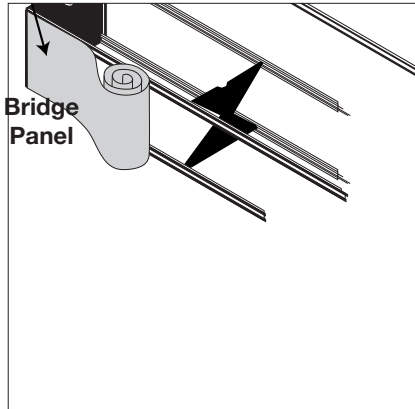
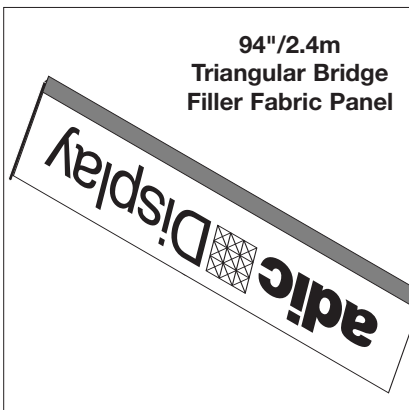
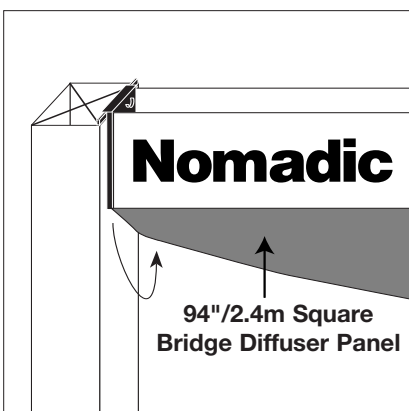
**94" / 2.4m Bridge Panel (Triangular or Square)****FPB94****Trim Size:**  $93^{1/2}''_W \times 14^{9/16}''_H$  /  $2375\text{mm}_W \times 370\text{mm}_H$ **Live Image Area :**  $90^{1/2}''_W \times 12^{1/2}''_H$  /  $2299\text{mm}_W \times 318\text{mm}_H$ **94" / 2.4m Triangular Bridge Filler Fabric Panel****BFPT94****Trim Size:**  $93^{5/8}''_W \times 1^{5/8}''_H$  /  $2378\text{mm}_W \times 41\text{mm}_H$ **Hinge Width Specification :**  $^{13/16}'' + ^{13/16}''$  /  $20^{1/2}\text{mm} + 20^{1/2}\text{mm}$ **94" / 2.4m Square Bridge Diffuser Panel****BDP94****Trim Size:**  $93^{5/8}''_W \times 12^{11/16}''_H$  /  $2378\text{mm}_W \times 322\text{mm}_H$ Nomadic  Display <sup>®</sup>

## Instructions for Mounting Graphic Panels on Columns and Towers

Nomadic recommends that you order the appropriate magnetic mounting materials to produce strips and panels. Please refer to the Graphics Production Materials page in the Accessories section of your green Nomadic Display Answer Book I.

### Before you begin

Read through these instructions and refer to the Graphic Specification Table for standard or *hinged* strip and panel trim dimensions. It is recommended that you set up your Instand frame so that your completed graphic panels can be hung and checked. If necessary, stiffeners and magnetic tape can be removed and relocated before the adhesive fully sets.

For instructions on mounting standard panels see *Instructions for Mounting Graphic Panels on Nomadic Instand Plus* page 13.

For instructions on mounting *hinged* panels see *Instructions for Mounting Hinged Graphic Panels on Nomadic Instand Plus* page 26.



Name

Equivalent Fabric Code

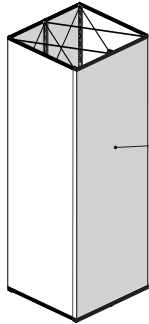
**Three Quad High Large Flat Rectangular Tower End Cap****FEU3FRT**

Three Quad  
High Large Flat  
Rectangular  
Tower End Cap

**Trim Size:**  $30^{7/16}{}''_W \times 89^{3/4}{}''_H / 773_W \times 2280\text{mm}_H$

**Hinge Specifications:**  $1''+28^{7/16}{}''+1'' / 25+723+25\text{mm}$

**Aluminum Bars (Top/Bottom):** Yes / Yes — 26.97"/ 685mm

**Aluminum Bar Code:** GSATFRT (x2)

**Stiffener Punch (Top/Bottom):** Notched/Plain

**Required Stiffeners (Top/Bottom):** Y-GEU3CST-01, Y-GEU3CSB-01

**Four Quad High Large Flat Rectangular Tower End Cap****FEU4FRT**

Four Quad High  
Large Flat  
Rectangular  
Tower End Cap

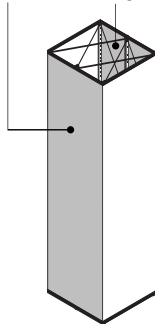

**Trim Size:**  $30^{7/16}{}''_W \times 120^{1/2}{}''_H / 773_W \times 3060\text{mm}_H$

**Hinge Specifications:**  $1''+28^{7/16}{}''+1'' / 25+723+25\text{mm}$

**Aluminum Bars (Top/Bottom):** Yes / Yes — 26.97"/ 685mm

**Aluminum Bar Code:** GSATFRT (x2)

**Stiffener Punch (Top/Bottom):** Notched/Plain

**Required Stiffeners (Top/Bottom):** Y-GEU3CST-01, Y-GEU3CSB-01

**Five Quad High Large Flat Rectangular Tower End Cap****FEU5FRT**

Five Quad High  
Large Flat  
Rectangular  
Tower End Cap

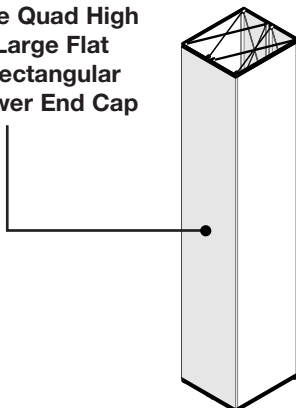

**Trim Size:**  $30^{7/16}{}''_W \times 151^{1/4}{}''_H / 773_W \times 3842\text{mm}_H$

**Hinge Specifications:**  $1''+28^{7/16}{}''+1'' / 25+723+25\text{mm}$

**Aluminum Bars (Top/Bottom):** Yes / Yes — 26.97"/ 685mm

**Aluminum Bar Code:** GSATFRT (x2)

**Stiffener Punch (Top/Bottom):** Notched/Plain

**Required Stiffeners (Top/Bottom):** Y-GEU3CST-01, Y-GEU3CSB-01

Name

Equivalent Fabric Code

**Three Quad High Connecting End Cap**

**FEU3C**

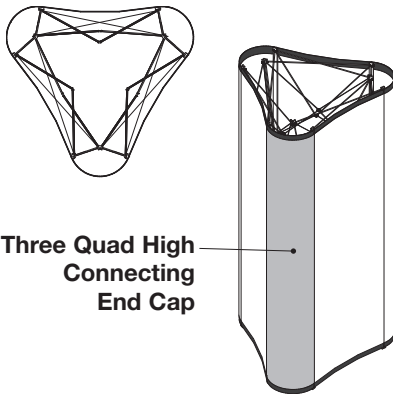

Three Quad High Connecting End Cap

**Trim Size:** 18" <sub>W</sub> x 89 <sup>3/4</sup>" <sub>H</sub> / 457 <sub>W</sub> x 2280mm <sub>H</sub>

**Aluminum Bars (Top/Bottom):** None

**Stiffener Punch (Top/Bottom):** Notched/Plain

**Required Stiffeners (Top/Bottom):** GSC18T, GSC18B

**Three Quad High Large In Cap**

**FIU3L**

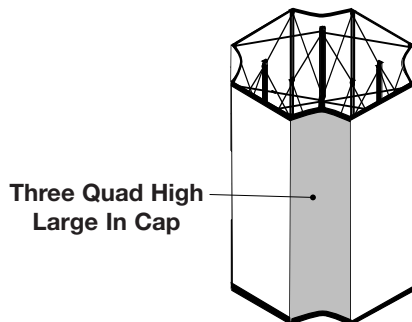

Three Quad High Large In Cap

**Trim Size:** 24 <sup>1/2</sup>" <sub>W</sub> x 89 <sup>3/4</sup>" <sub>H</sub> / 623 <sub>W</sub> x 2280mm <sub>H</sub>

**Hinge Specifications:** 1" + 22 <sup>1/2</sup>" + 1" / 25 + 572 + 25mm

**Aluminum Bars (Top/Bottom):** None

**Stiffener Punch (Top/Bottom):** Notched/Plain

**Required Stiffeners (Top/Bottom):** YGSIT, YGSIB

**Four Quad High Large In Cap**

**FIU4L**

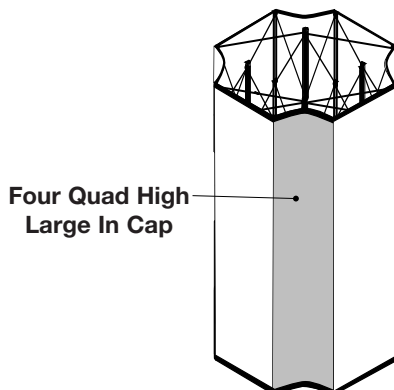

Four Quad High Large In Cap

**Trim Size:** 24 <sup>1/2</sup>" <sub>W</sub> x 120 <sup>1/2</sup>" <sub>H</sub> / 623 <sub>W</sub> x 3060mm <sub>H</sub>

**Hinge Specifications:** 1" + 22 <sup>1/2</sup>" + 1" / 25 + 572 + 25mm

**Aluminum Bars (Top/Bottom):** None

**Stiffener Punch (Top/Bottom):** Notched/Plain

**Required Stiffeners (Top/Bottom):** YGSIT, YGSIB

## Instructions for Mounting a Wrap Around Header on Nomadic Instand<sup>®</sup>

### Standard Headers

Headers are the long, horizontal graphic panels placed at the top of a display to identify a company, product, service or slogan.

The traditional methods for producing Instand headers are vinyl graphics and letters, screen printing and photographic/digital reproduction. Combining one or more of these techniques can produce unique effects. Nomadic recommends 15-20 mil. Lexan<sup>®</sup> as the suggested material.

### Step 1 - Trim the Header

Header sizes may vary according to specific design requirements. However, recommended trim dimensions are provided below:

|             |   |
|-------------|---|
| Height      | 7" to 15" / 178mm to 381mm                            |
| Instand C34 | 14"-15" x 148 <sup>1/2</sup> " / 356mm-381mm x 3772mm |
| Instand C33 | 14"-15" x 119 <sup>1/4</sup> " / 356mm-381mm x 3029mm |
| Instand C23 | 10" x 119 <sup>1/4</sup> " / 254mm x 3029mm           |

### Step 2 - Affix Hook Tape

Lay the graphic panel face down on a protected surface. Lay the 1/4"/6mm hook tape down along the full length of the strip at the top and the bottom edges. Press firmly on backing to affix tape to the graphic strip.

### Headliners

HeadLiner is the rollable backlit header for C33 and C34 Instand Classic displays and Table Top models. Nomadic recommends that you order the 25 mil. flame-retardant Lexan<sup>®</sup> to produce backlit headers.

**Name**

**Equivalent Fabric Code**

## 8' / 2.4m HeadLiner Kit Components

**HRE005**

|   |         |                                       |
|---|---------|---------------------------------------|
| 1 | HK08FEL | 8' / 2.4m End Piece - Left Rigid      |
| 1 | HK08FER | 8' / 2.4m End Piece - Right Rigid     |
| 4 | HMSF    | 30 5/8" / 778mm Straight Frame Module |
| 2 | HMSF07  | 7 3/4" / 197mm HeadLiner Module       |
| 2 | HR      | HeadLiner Light Bar                   |
| 6 | LBIST   | Incandescent 75w standard bulb        |
| 1 | LE      | ElectroStrut.                         |

### Graphic Material Recommendation

|            |  |
|------------|--|
| Substrate: | Recommend Flame-Retardant FR 65 Lexan <sup>®</sup> Velvet Front,<br>Smooth Reverse                                 |
| Gauge:     | 25 mil / 0.6mm   |
| Height:    | 14 9/16" / 370mm   |
| Length:    | 83 1/2" / 2121mm   |
| Printing:  | Recommend 2nd surface (on smooth reverse) printing. Note that front surface will be exposed when packed correctly. |

**Name**

**Equivalent Fabric Code**

## 10' / 3m HeadLiner Kit Components

**HRE004**

|   |         |  |
|---|---------|--|
| 1 | HK10FEL | 10' / 3m End Piece - Left Rigid                  |
| 1 | HK10FER | 10' / 3m End Piece - Right Rigid                 |
| 6 | HMSF    | 30 <sup>5/8"</sup> / 778mm Straight Frame Module |
| 3 | HR      | HeadLiner Light Bar                              |
| 9 | LBIST   | Incandescent 75w standard bulb                   |
| 1 | LE      | ElectroStrut.                                    |

### Graphic Material Recommendation

|            |  |
|------------|--|
| Substrate: | Recommend Flame-Retardant FR 65 Lexan <sup>Ñ</sup> Velvet Front,<br>Smooth Reverse                                 |
| Gauge:     | 25 mil / 0.6mm   |
| Height:    | 14 <sup>9/16"</sup> / 370mm  |
| Length:    | 106 <sup>3/8"</sup> / 2702mm   |
| Printing:  | Recommend 2nd surface (on smooth reverse) printing. Note that front surface will be exposed when packed correctly. |

**Name**

**Equivalent Fabric Code**

## Mini Classic HeadLiner Kit Components

**H00007**

|   |         |                                       |
|---|---------|---------------------------------------|
| 1 | HK08FEL | 802.4m End Piece - Left Rigid         |
| 1 | HK10FER | 802.4m End Piece - Right Rigid        |
| 2 | HMSF    | 30 5/8" / 778mm Straight Frame Module |
| 2 | HMSF17  | 17 11/16" / 449mm HeadLiner Module    |
| 1 | LE      | ElectroStrut                          |
| 1 | LFFC    | HeadLiner Flourescent Light           |

### Graphic Material Recommendation

|            |  |
|------------|--|
| Substrate: | Recommend Flame-Retardant FR 65 Lexan <sup>Ñ</sup> Velvet Front, Smooth Reverse                                    |
| Gauge:     | 25 mil / 0.6mm   |
| Height:    | 14 9/16" / 370mm   |
| Length:    | 62 3/4" / 1594mm   |
| Printing:  | Recommend 2nd surface (on smooth reverse) printing. Note that front surface will be exposed when packed correctly. |

## Instructions for Mounting HeadLiner on Nomadic Instand

### Before you begin

Read through these instructions first. It is recommended that you set up your Instand display so that your completed HeadLiner can be hung and checked.

### Step 1

Beginning from  $1\frac{3}{16}$ "/21mm from the right or left edge of the graphics, carefully apply  magnetic foam backed tape  $\frac{1}{16}$ "/1.5mm from the top edge of the graphics. See Figure 1

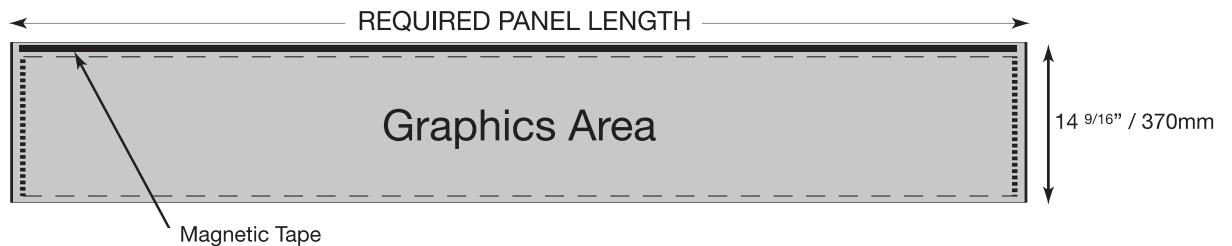

**Fig. 1**

### Step 2

Beginning from  $1\frac{3}{16}$ "/21mm from the right or left edge of the graphics, carefully apply  magnetic foam backed tape  $\frac{1}{16}$ "/1.5mm from the bottom edge of the graphics. See Figure 2.

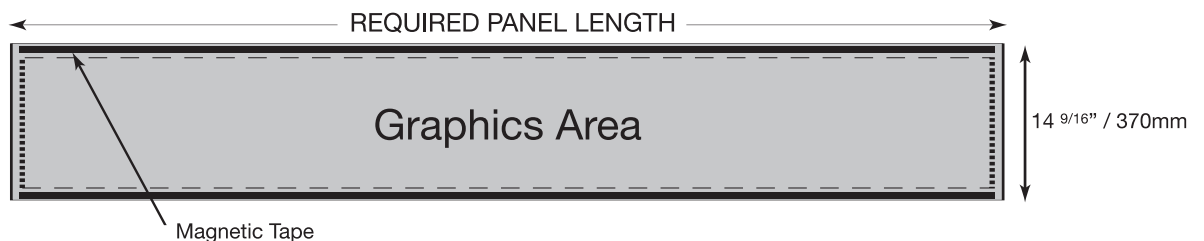

**Fig. 2**

**Step 3**

At each end of the Headliner place 1/2"/12.5mm Velcro® loop strips 1/16"/1.5mm from each end leaving a 9/16"/14mm gap on the top and bottom. See Figure 3.

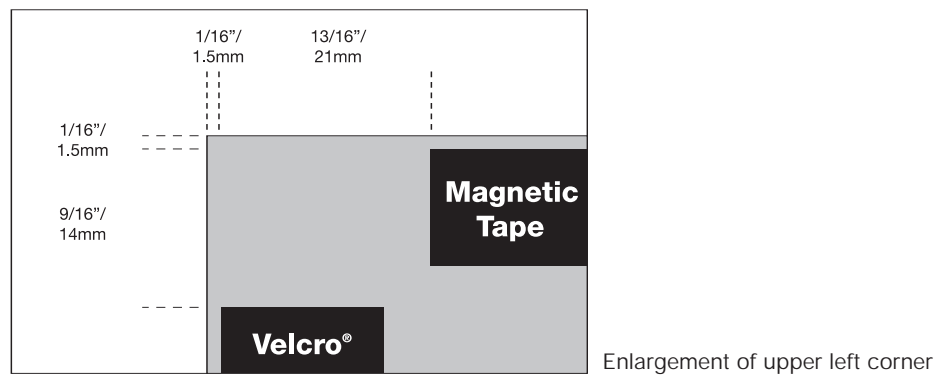
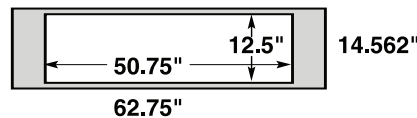

**Fig. 3**

**Panel Specs:**

The larger gray box is the trim size for graphic panels.  
The smaller white box is the live area for your graphic.

**C22:**



**C23,33:**

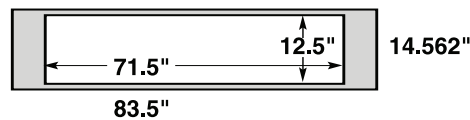

**C34:**

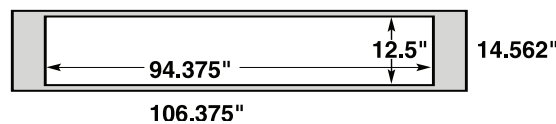



## Example of Stiffener and Magnet Mounting

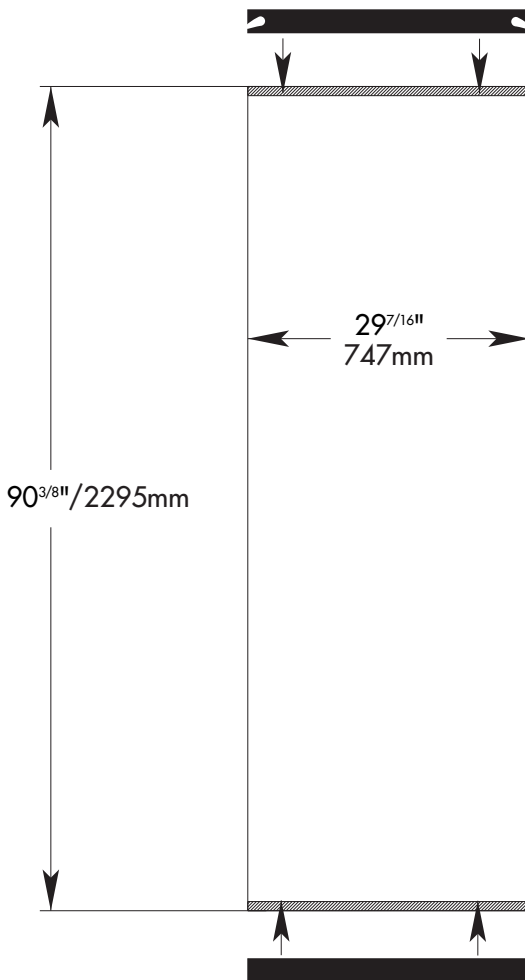

**Fig. 1**

Apply 1" / 25mm double backed adhesive tape to top and bottom

Attach top and bottom stiffeners

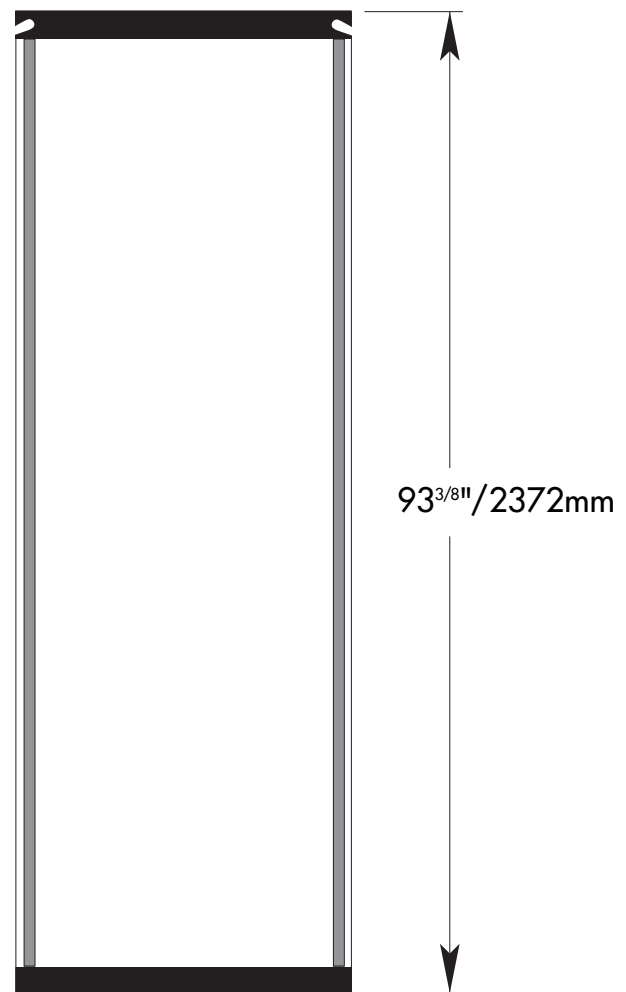

**Fig. 2**

Apply magnetic tape  $\frac{1}{16}'' / 1.5\text{mm}$  from outer edges

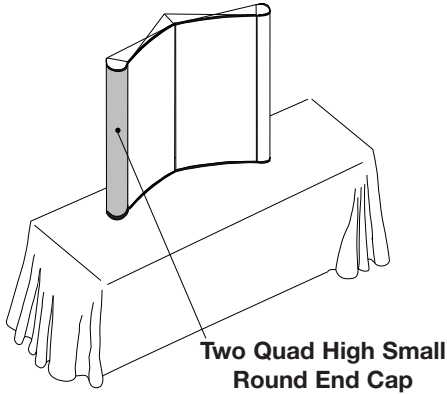
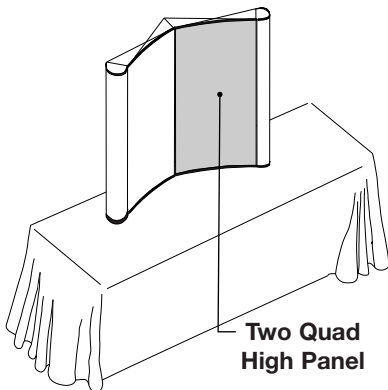
**Name****Equivalent Fabric/Graphic Code****Two Quad High Small Round End Cap Traveler FETR2SR/INK-V21560****Trim Size:** 15" <sub>W</sub> x 59<sup>5/8</sup>" <sub>H</sub> / 381<sub>W</sub> x 1514<sub>mmH</sub>**Stiffener Punch (Top/Bottom):** Notched/Plain**Required Stiffeners (Top/Bottom):** GSSRT, GSSRB**Two Quad High Panel Traveler****FPTR2/INK-V23060****Trim Size:** 29<sup>7/16</sup>" <sub>W</sub> x 59<sup>5/8</sup>" <sub>H</sub> / 747<sub>W</sub> x 1514<sub>mmH</sub>**Stiffener Punch (Top/Bottom):** Notched/Plain**Required Stiffeners (Top/Bottom):** GSCLT, GSCLB

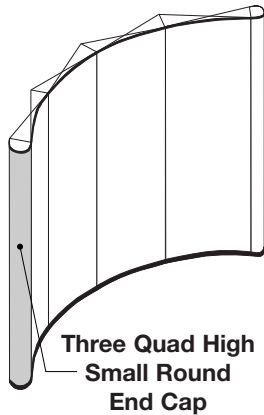
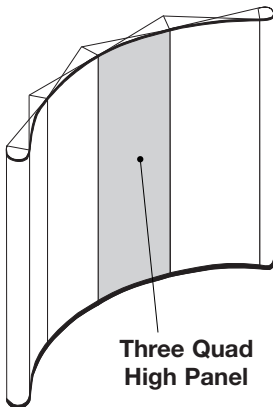
**Name****Equivalent Fabric/Graphic Code****Three Quad High Small Round End Cap Traveler****FETR3SR/INK-V31590****Trim Size:** 15" <sub>W</sub> x 90 <sup>3/8</sup>" <sub>H</sub> / 381 <sub>W</sub> x 2295 <sub>H</sub>mm**Stiffener Punch (Top/Bottom):** Notched/Plain**Three Quad High Panel Traveler****FPTR3/INK-V33090****Trim Size:** 29 <sup>7/16</sup>" <sub>W</sub> x 90 <sup>3/8</sup>" <sub>H</sub> / 747 <sub>W</sub> x 2295 <sub>H</sub>mm**Stiffener Punch (Top/Bottom):** Notched/Plain

Name

Equivalent Fabric/Graphic Code

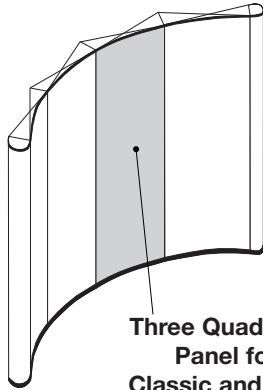
**Three Quad High Panel**
**FPC3/FPI3/INK-33090**

Three Quad High  
Panel for  
Classic and Ideal

**Trim Size:**  $29^{7/16}''_W \times 89^{3/4}''_H / 747_W \times 2280\text{mm}_H$

**Stiffener Punch (Top/Bottom):** Notched/Plain

**Required Stiffeners (Top/Bottom):** GSCLT, GSCLB

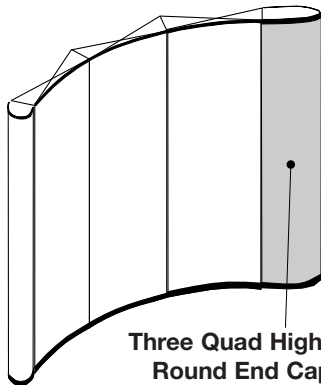
**Three Quad High Large Round End Cap FEC3LR/FEI3LR/INK-31590E**

Three Quad High Large  
Round End Cap for  
Classic and Ideal

**Trim Size:**  $29^{7/16}''_W \times 89^{3/4}''_H / 747_W \times 2280\text{mm}_H$

**Stiffener Punch (Top/Bottom):** Notched/Plain

**Required Stiffeners (Top/Bottom):** GSCLTR, GSCLTB

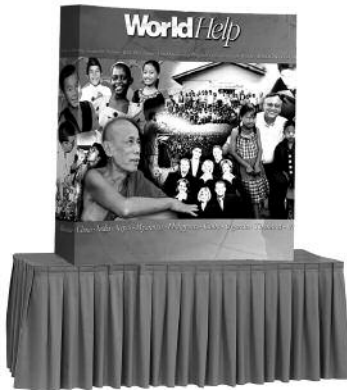

## FabriMural™

Since we cannot accurately predict the shrink and/or stretch of printed fabric, we strongly recommend that critical text or logo elements be placed at a minimum of 4" from any side of the fabric graphic. When we preflight the file, we will add sufficient bleed to assure that nothing will be eliminated in the finishing process. If the files provided do not allow us to do so, we will inform you before production. We prefer layered PSD or Adobe Illustrator files that will allow us to perform the proper preflight procedures.

**Files sizes for FabriMural should be 4" larger than the finished graphics.**

| <u>Frame</u>   | <u>Graphic Image Size</u> | <u>Frame</u>    | <u>Graphic Image Size</u> |
|----------------|---------------------------|-----------------|---------------------------|
| T22            | 66.5" x 66.5"             | TC22            | 62.5" x 59.5"             |
| T22 w/ Endcaps | 66.5" x 92.5"             | TC22 w/ Endcaps | 62.5" x 76.5"             |
| T32            | 66.5" x 97"               | TC33            | 91.75" x 88.5"            |
| T32 w/ Endcaps | 92.5" x 97"               | TC33 w/ Endcaps | 91.75" x 105.5"           |
| T33            | 97" x 97"                 | TC34            | 91.75" x 116.5"           |
| T33 w/ Endcaps | 97" x 123"                | TC34 w/ Endcaps | 91.75" x 133.5"           |

\* **Note:** Sizing assumes dye sub printed graphic is on poly knit material.

# Panel Vocabulary

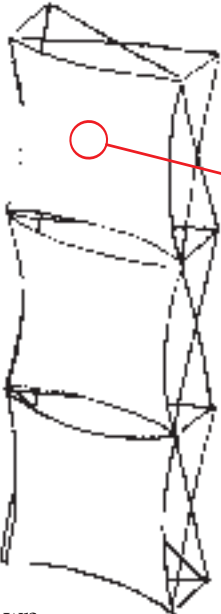

- Flat (front)
  - 4 corners attached to front

*A Flat (back) would be 4 corners attached at back*

shown

*FLAT (front)*  
3 flat (fronts) skins on a 1x3 unit



- Thread
  - Parallel corners attached to front
  - Parallel corners attached to back

*Fabric "Threads" through unit without twists*

*Can be horizontal or vertical*

shown

*THREAD (front top to back bottom)*  
1 thread & 1 Flat (front) on a 1x3 unit



- Single Twist Skin:
  - 3 corners attached to front
  - 1 corner back

*Single Twist Skin can also be reverse configured:*

- 1 corners attached to front
- 3 corner back

shown

*SINGLE TWIST (front)*  
2 single twist (front) & 1 flat (front) skins on a 1x3 unit



- Double Twist Skin:
  - 2 diagonal corners front
  - 2 diagonal corners back

shown

*DOUBLE TWIST*  
2 double twist & 1 flat (front) on a 1x3 unit

©2004/Patent Pending



800.844.8877

Nomadic  Display®

## Panel Guidelines

The **X-Factor** is the phenomenon that is a result of tension at four corners of an XPlus graphic. The X-Factor is greatest at the outer most corners of the graphic (A) and is least apparent at the center (B). Images closest to the edge of a graphic are exposed to more tension, resulting in some image and color distortion. 3" to 5" (D) from all sides is the **Focus Area (C)** of any XPlus graphic at any size. Outside the focus area is the greatest amount of distortion, buttonholes and sew lines..

When working with Tension Fabrics, all images are exposed to some amount of distortion. This is to be considered part of the XPlus look, and not a flaw. When working with images, like a logo, keep in mind that centering the image exposes it to the least amount of X-Factor (B). Additionally, areas of fabric that are closest to buttonholes are exposed to the greatest amount of tension. Since fibers, of any fabric, under tension are separated from each other on a micro level, tone and color modulating will occur. These characteristics are considered a natural attribute to the XPlus line.

The **Focus Area (C)** is the image area that is 3" to 5" (D) from all four sides of a graphic. The entire surface of the graphic will accept the image, however, the Focus Area is free from sew lines and buttonholes. The Focus Area is also the area where the X-Factor is least apparent. This makes the Focus Area suitable for text, logos or any other object that would not benefit from the distortion that increase toward the edge of a graphic.

The unique characteristics of the X-Factor only enhance the creative appeal and energy of the XPlus design. The audience is invited to explore the depth, movement and excitement not found on more static systems making XPlus the exiting product it has become.

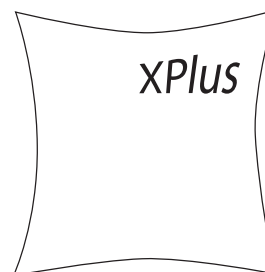
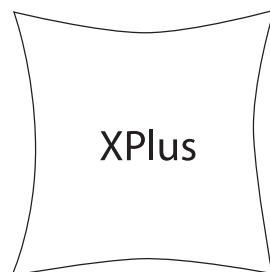
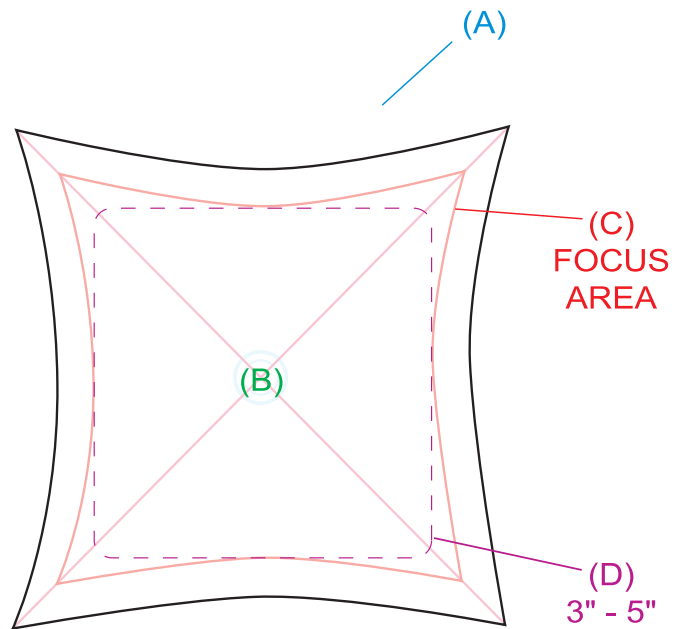

## XCalibur Configurations Table



**PX31M\_A**  
Panel 1 (x1)  
Panel 11 (x1)



**PX31M\_B**  
Panel 1 (x1)  
Panel 11 (x1)



**PX31M\_C**  
Panel 1 (x2)  
Panel 10 (x1)



**PX31M\_D**  
Panel 1 (x1)  
Panel 2 (x2)

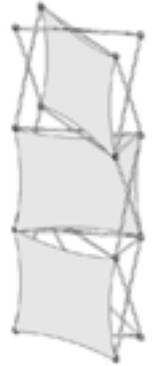

**PX31M\_E**  
Panel 1 (x1)  
Panel 3 (x2)



**PX31M\_F**  
Panel 1 (x1)  
Panel 4 (x1)  
Panel 5 (x1)



**PX31M\_G**  
Panel 1 (x1)  
Panel 5 (x2)



**PX31M\_H**  
Panel 1 (x1)  
Panel 8 (x1)



**PX31M\_I**  
Panel 1 (x1)  
Panel 11 (x1)



**PX31M\_J**  
Panel 5 (x1)  
Panel 9 (x1)

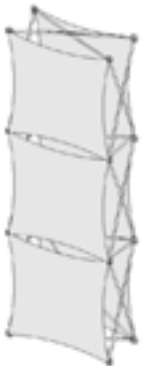

**PX31M\_K**  
Panel 1 (x1)  
Panel 5 (x1)  
Panel 9 (x1)



**PX31M\_L**  
Panel 6 (x3)  
Panel 11 (x1)



**PX31M\_M**  
Panel 1 (x4)

For detailed information on setting up your XPlus Kit, refer to our website:  
[www.nomadicdisplay.org](http://www.nomadicdisplay.org)

Nomadic  Display®



## XEcutive Configurations Table

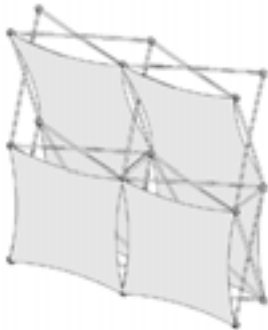

**PX22M\_A**  
Panel 1 (x2)  
Panel 7 (x2)

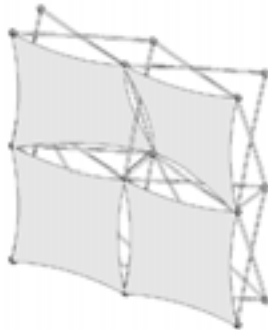

**PX22M\_B**  
Panel 1 (x2)  
Panel 4 (x2)



**PX22M\_C**  
Panel 1 (x1)  
Panel 4 (x1)  
Panel 9 (x1)

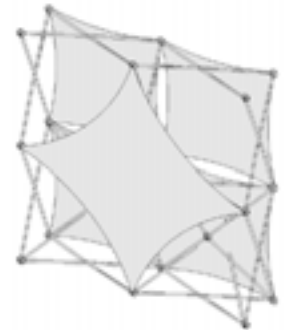

**PX22M\_D**  
Panel 1 (x2)  
Panel 14 (x1)  
Panel 18 (x1)

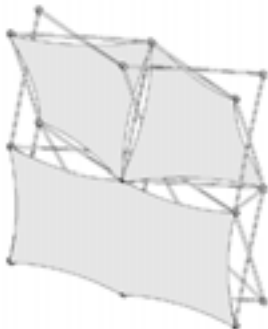

**PX22M\_E**  
Panel 5 (x2)  
Panel 13 (x1)

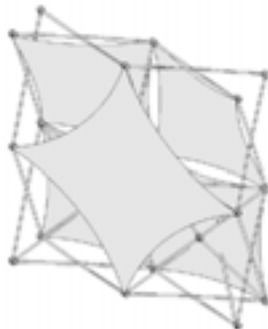

**PX22M\_F**  
Panel 4 (x2)  
Panel 13 (x1)  
Panel 18 (x1)

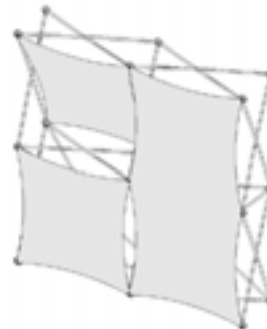

**PX22M\_G**  
Panel 1 (x1)  
Panel 2 (x1)  
Panel 6 (x1)

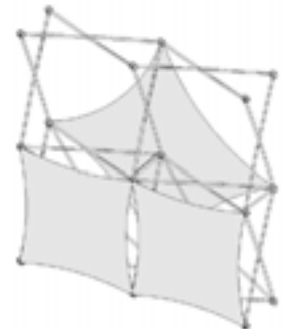

**PX22M\_H**  
Panel 1 (x2)  
Panel 18 (x1)

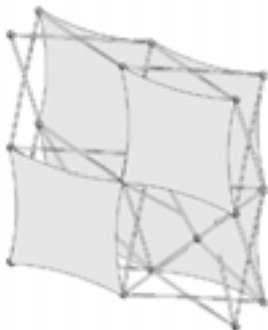

**PX22M\_I**  
Panel 1 (x2)  
Panel 17 (x1)

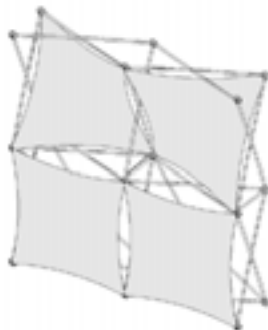

**PX22M\_J**  
Panel 1 (x2)  
Panel 5 (x1)

For detailed information on setting up your XPlus Kit, refer to our website:  
[www.nomadicdisplay.org](http://www.nomadicdisplay.org)

Nomadic  Display®

## XPert Configurations Table



**PX32M\_A**  
Panel 1 (x2)  
Panel 11 (x2)

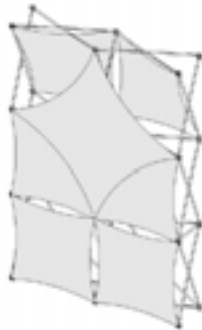

**PX32M\_B**  
Panel 1 (x2)  
Panel 4 (x4)  
Panel 18 (x1)



**PX32M\_C**  
Panel 13 (x2)  
Panel 15 (x1)

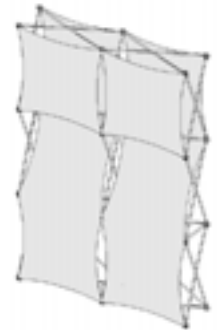

**PX32M\_D**  
Panel 1 (x2)  
Panel 11 (x2)

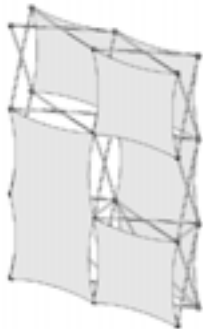

**PX32M\_E**  
Panel 1 (x2)  
Panel 6 (x2)  
Panel 13 (x1)

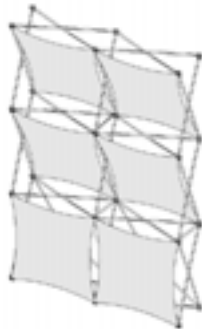

**PX32M\_F**  
Panel 1 (x2)  
Panel 2 (x4)



**PX32M\_G**  
Panel 1 (x1)  
Panel 7 (x1)  
Panel 9 (x1)  
Panel 14 (x1)

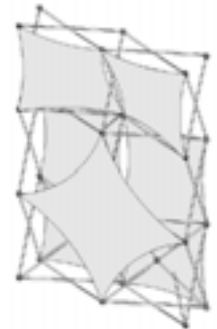

**PX32M\_H**  
Panel 4 (x2)  
Panel 6 (x2)  
Panel 18 (x1)

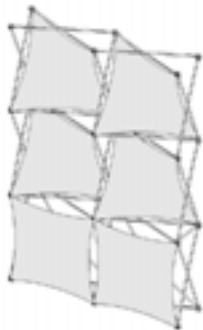

**PX32M\_I**  
Panel 1 (x2)  
Panel 5 (x4)

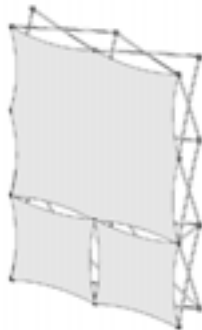

**PX32M\_J**  
Panel 1 (x2)  
Panel 17 (x1)

For detailed information on setting up your XPlus Kit, refer to our website:  
[www.nomadicdisplay.org](http://www.nomadicdisplay.org)

Nomadic  Display®

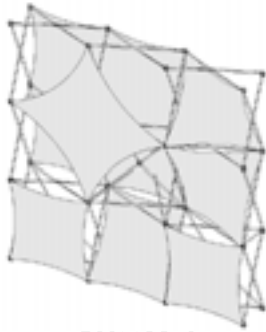
**XQusite Configurations Table****PX33M\_A**

Panel 1 (x2)  
Panel 2 (x1)  
Panel 5 (x2)  
Panel 17 (x1)  
Panel 18 (x1)

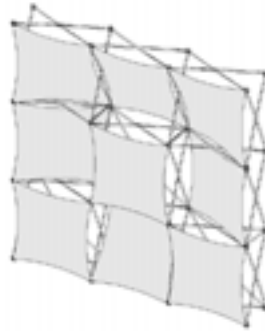
**PX33M\_B**

Panel 1 (x3)  
Panel 2 (x2)  
Panel 3 (x2)  
Panel 4 (x2)

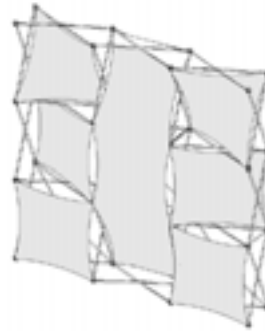
**PX33M\_C**

Panel 1 (x2)  
Panel 3 (x2)  
Panel 5 (x2)  
Panel 12 (x1)

**PX33M\_D**

Panel 1 (x3)  
Panel 2 (x2)  
Panel 5 (x2)  
Panel 21 (x1)

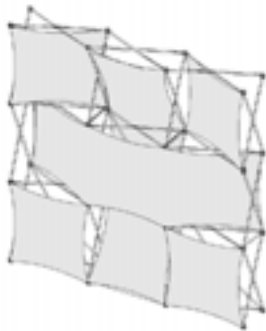
**PX33M\_E**

Panel 1 (x2)  
Panel 3 (x2)  
Panel 12 (x1)  
Panel 21 (x1)

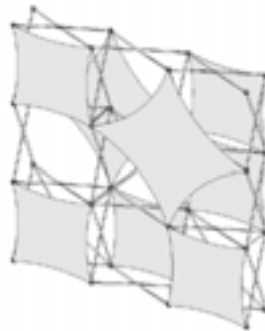
**PX33M\_F**

Panel 1 (x6)  
Panel 18 (x2)

**PX33M\_G**

Panel 1 (x3)  
Panel 11 (x2)  
Panel 12 (x1)

**PX33M\_H**

Panel 1 (x3)  
Panel 7 (x4)  
Panel 11 (x1)

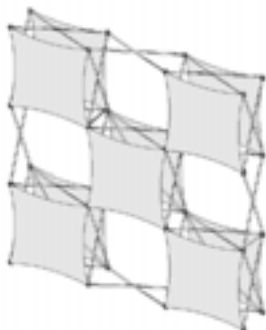
**PX33M\_I**

Panel 1 (x10)

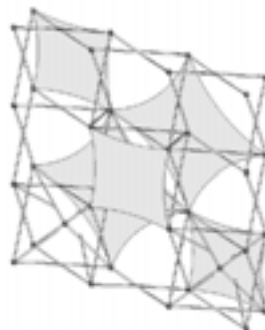
**PX33M\_J**

Panel 1 (x3)  
Panel 18 (x2)

**PX33M\_K**

Panel 1 (x2)  
Panel 2 (x1)  
Panel 14 (x2)  
Panel 17 (x1)

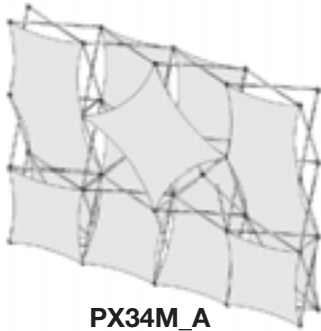
**XTreme Configurations Table**

**PX34M\_A**  
Panel 1 (x2)  
Panel 11 (x4)  
Panel 18 (x1)

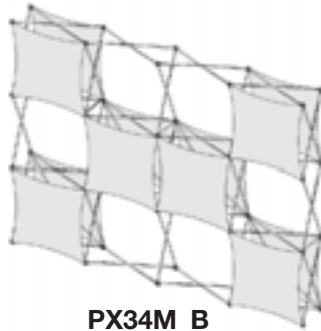

**PX34M\_B**  
Panel 1 (x12)

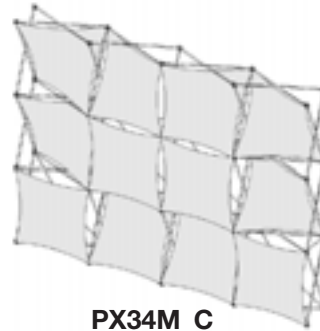

**PX34M\_C**  
Panel 1 (x4)  
Panel 2 (x2)  
Panel 4 (x2)  
Panel 5 (x4)

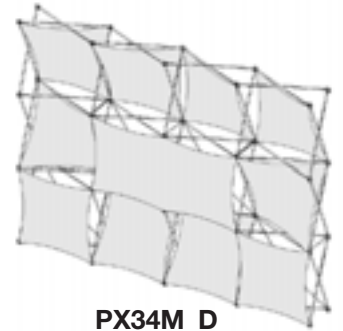

**PX34M\_D**  
Panel 1 (x2)  
Panel 2 (x2)  
Panel 4 (x4)  
Panel 5 (x2)  
Panel 13 (x1)

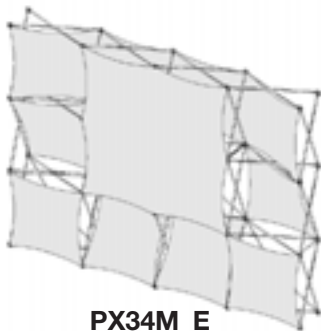

**PX34M\_E**  
Panel 1 (x2)  
Panel 2 (x2)  
Panel 4 (x2)  
Panel 17 (x1)  
Panel 23 (x1)

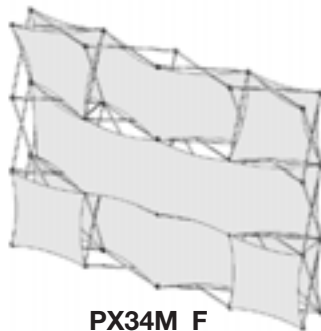

**PX34M\_F**  
Panel 1 (x2)  
Panel 5 (x2)  
Panel 23 (x3)

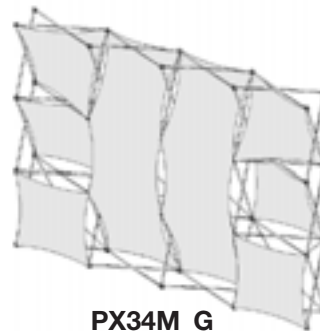

**PX34M\_G**  
Panel 1 (x2)  
Panel 4 (x2)  
Panel 5 (x2)  
Panel 12 (x2)

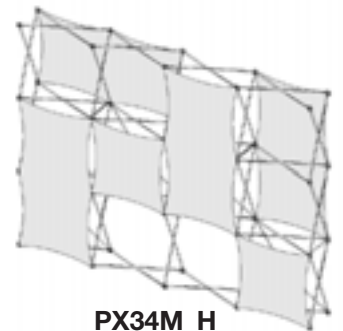

**PX34M\_H**  
Panel 1 (x2)  
Panel 6 (x3)  
Panel 13 (x1)

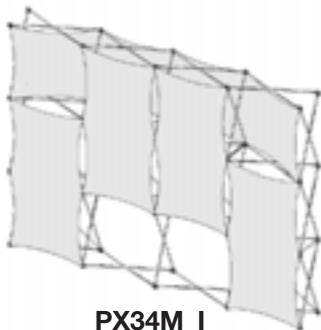

**PX34M\_I**  
Panel 6 (x4)  
Panel 23 (x1)

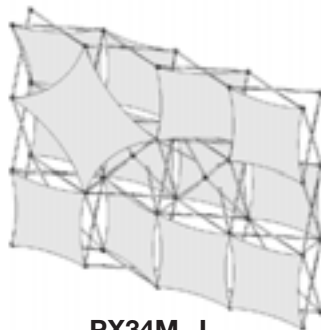

**PX34M\_J**  
Panel 1 (x9)  
Panel 3 (x2)  
Panel 4 (x1)  
Panel 18 (x1)

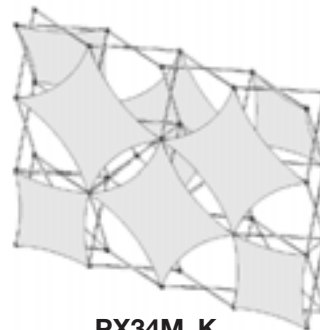

**PX34M\_K**  
Panel 1 (x2)  
Panel 4 (x2)  
Panel 18 (x4)

For detailed information on setting up your XPlus Kit, refer to our website:  
[www.nomadicdisplay.org](http://www.nomadicdisplay.org)

Nomadic  Display®

## XPedition Configurations Table

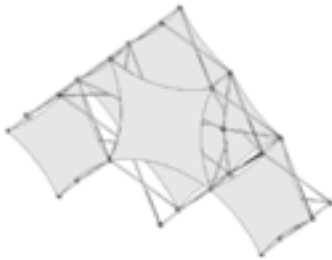
**PXPYRM\_A**

Panel 4 (x2)  
Panel 17 (x1)  
Panel 18 (x1)

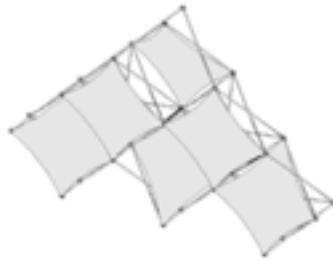
**PXPYRM\_B**

Panel 1 (x2)  
Panel 4 (x4)

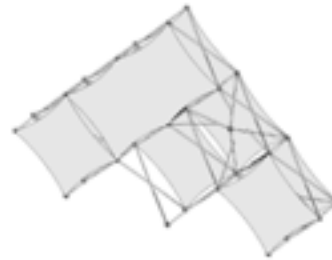
**PXPYRM\_C**

Panel 1 (x4)  
Panel 6 (x2)  
Panel 13 (x1)

**PXPYRM\_D**

Panel 1 (x3)  
Panel 4 (x3)  
Panel 17 (x1)

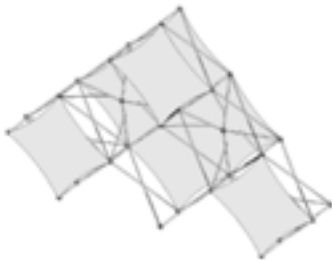
**PXPYRM\_E**

Panel 1 (x3)  
Panel 17 (x1)

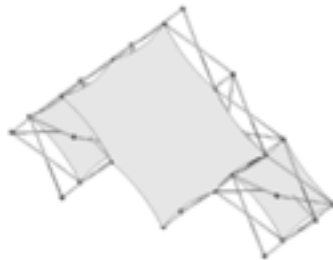
**PXPYRM\_F**

Panel 1 (x2)  
Panel 17 (x1)

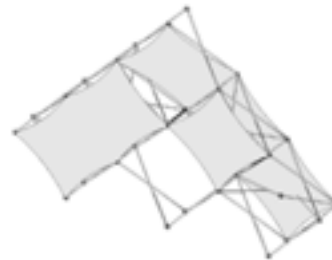
**PXPYRM\_G**

Panel 1 (x1)  
Panel 11 (x1)  
Panel 13 (x1)

**PXPYRM\_H**

Panel 1 (x5)  
Panel 18 (x1)

**PXPYRM\_I**

Panel 1 (x2)  
Panel 4 (x1)  
Panel 18 (x1)

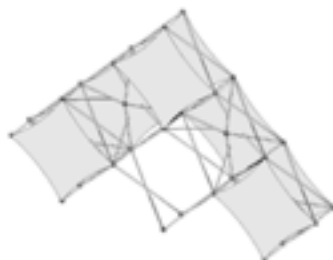
**PXPYRM\_J**

Panel 1 (x3)  
Panel 6 (x1)  
Panel 19 (x1)

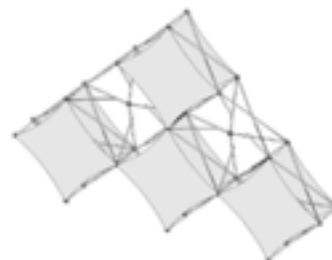
**PXPYRM\_K**

Panel 1 (x8)

For detailed information on setting up your XPlus Kit, refer to our website:  
[www.nomadicdisplay.org](http://www.nomadicdisplay.org)

Nomadic  Display®

## XPlorer Configurations Table

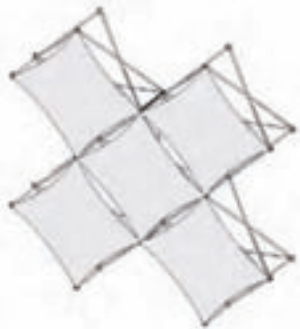

**PXXPM\_A**  
Panel 1 (x5)



**PXXPM\_B**  
Panel 1 (x1)  
Panel 4 (x4)



**PXXPM\_C**  
Panel 1 (x5)  
Panel 18 (x2)



**PXXPM\_D**  
Panel 4 (x4)  
Panel 18 (x2)



**PXXPM\_E**  
Panel 1 (x1)  
Panel 4 (x4)  
Panel 18 (x1)



**PXXPM\_F**  
Panel 1 (x5)  
Panel 18 (x2)

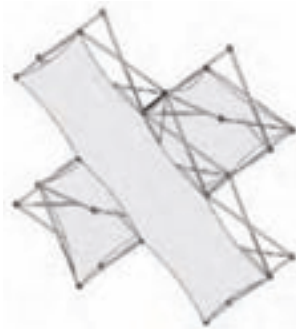

**PXXPM\_G**  
Panel 10 (x1)  
Panel 22 (x1)

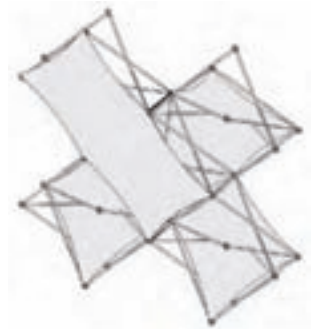

**PXXPM\_H**  
Panel 4 (x2)  
Panel 6 (x1)  
Panel 16 (x1)

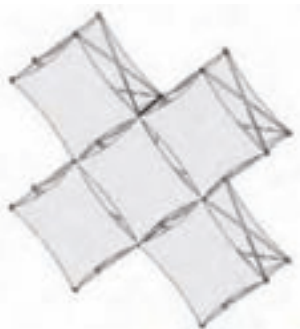

**PXXPM\_I**  
Panel 1 (x10)



**PXXPM\_J**  
Panel 1 (x4)  
Panel 18 (x2)

Name

Type

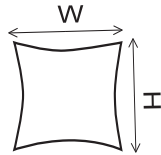
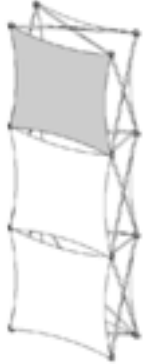
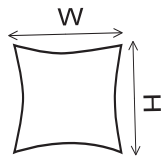
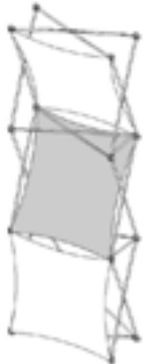
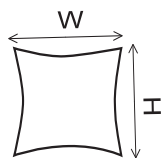
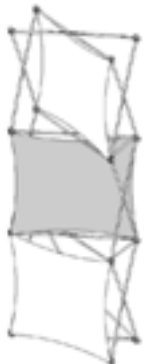
**Panel 1****1x1 Flat****Trim Size:** 27.5" <sub>W</sub> x 27.5" <sub>H</sub> / 698.5<sub>W</sub> x 698.5<sub>mmH</sub>**Panel 2****1x1 Vertical Thread****Trim Size:** 27.5" <sub>W</sub> x 29.5" <sub>H</sub> / 698.5<sub>W</sub> x 749.3<sub>mmH</sub>**Panel 3****1x1 Horizontal Thread****Trim Size:** 29.5" <sub>W</sub> x 27.5" <sub>H</sub> / 749.3<sub>W</sub> x 698.5<sub>mmH</sub>

800.844.8877

Nomadic  Display®

Name

Type

**Panel 4**

**1x1 Single Twist**

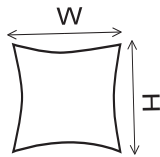

**Trim Size:** 28"<sub>W</sub> x 28"<sub>H</sub> / 711.2<sub>W</sub> x 711.2<sub>mmH</sub>

**Panel 5**

**1x1 Double Twist**

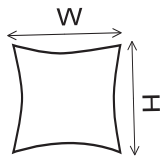

**Trim Size:** 29"<sub>W</sub> x 29"<sub>H</sub> / 736.6<sub>W</sub> x 736.6<sub>mmH</sub>

**Panel 6**

**1x2 Flat**

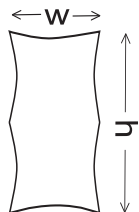

**Trim Size:** 27.5"<sub>W</sub> x 55"<sub>H</sub> / 698.5<sub>mmW</sub> x 1397<sub>H</sub>



800.844.8877

Nomadic  Display®



Name

Type

**Panel 7**

**1x2 Single Thread**

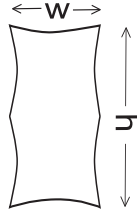

**Trim Size:** 27.5" <sub>W</sub> x 57" <sub>H</sub> / 698.5<sub>W</sub> x 1447.8mm<sub>H</sub>

**Panel 8**

**1x2 Double Thread**

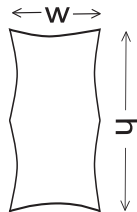

**Trim Size:** 27.5" <sub>W</sub> x 59" <sub>H</sub> / 736.6<sub>W</sub> x 1498.6mm<sub>H</sub>

**Panel 9**

**1x2 Single Twist**

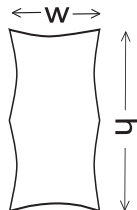
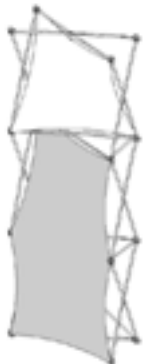

**Trim Size:** 28" <sub>W</sub> x 55.5" <sub>H</sub> / 711.2<sub>W</sub> x 1409.7mm<sub>H</sub>



800.844.8877

Nomadic  Display®

Name

Type

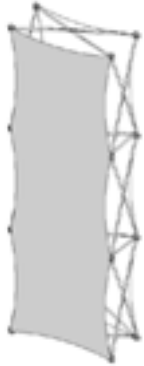
**Panel 10****1x3 Flat**

**Trim Size:** 27.5"<sub>W</sub> x 82.5"<sub>H</sub> / 698.5<sub>W</sub> x 2095.5<sub>mm</sub><sub>H</sub>

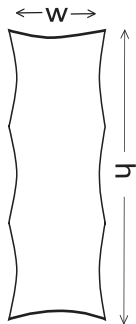
**Panel 11****1x3 Single Thread**

**Trim Size:** 27.5"<sub>W</sub> x 84.5"<sub>H</sub> / 736.6<sub>W</sub> x 2146.3<sub>mm</sub><sub>H</sub>

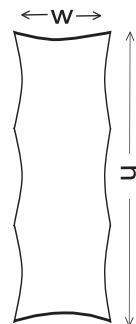
**Panel 12****1x3 Double Thread**

**Trim Size:** 28"<sub>W</sub> x 86.5"<sub>H</sub> / 711.2<sub>W</sub> x 2197.1<sub>mm</sub><sub>H</sub>



800.844.8877

Nomadic  Display®

Name

Type

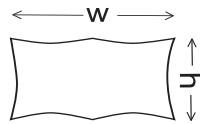
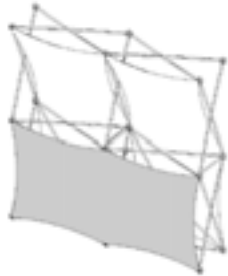
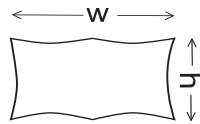
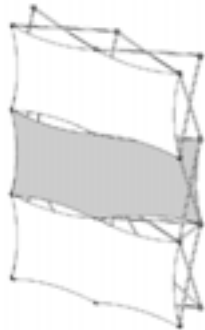
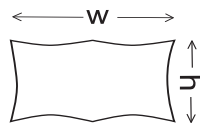
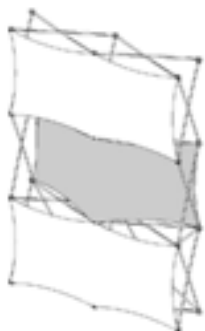
**Panel 13****2x1 Flat****Trim Size:** 55"<sub>w</sub> x 27.5"<sub>H</sub> / 1397<sub>w</sub> x 698.5mm<sub>H</sub>**Panel 14****2x1 Single Thread****Trim Size:** 57"<sub>w</sub> x 27.5"<sub>H</sub> / 1447.8<sub>w</sub> x 698.5mm<sub>H</sub>**Panel 15****2x1 Double Thread****Trim Size:** 59"<sub>w</sub> x 27.5"<sub>H</sub> / 1498.6<sub>w</sub> x 698.5mm<sub>H</sub>

800.844.8877

Nomadic  Display®

Name

Type

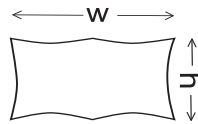
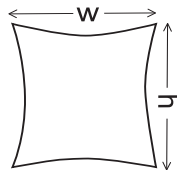
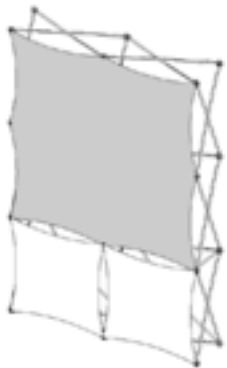
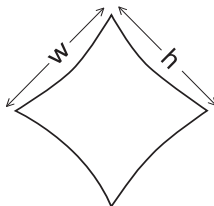
**Panel 16****2x1 Single Twist****Trim Size:** 55.5"<sub>w</sub> x 28"<sub>H</sub> / 1409.7<sub>w</sub> x 711.2<sub>mmH</sub>**Panel 17****2x2 Flat****Trim Size:** 55"<sub>w</sub> x 55"<sub>H</sub> / 1397<sub>w</sub> x 1397<sub>mmH</sub>**Panel 18****2x2 Diamond****Trim Size:** 40"<sub>w</sub> x 40"<sub>H</sub> / 1016<sub>w</sub> x 1016<sub>mmH</sub>

800.844.8877

Nomadic  Display®

Name

Type

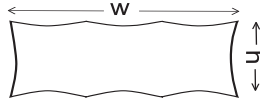
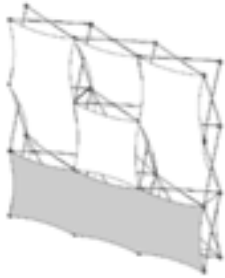
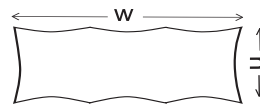
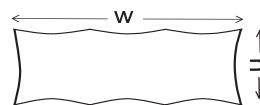
**Panel 19****3x1 Flat****Trim Size:** 82.5"<sub>w</sub> x 27.5"<sub>H</sub> / 2095.5<sub>w</sub> x 698.5<sub>mmH</sub>**Panel 20****3x1 Single Thread****Trim Size:** 84.5"<sub>w</sub> x 27.5"<sub>H</sub> / 2146.3<sub>w</sub> x 698.5<sub>mmH</sub>**Panel 21****3x1 Double Thread****Trim Size:** 86.5"<sub>w</sub> x 27.5"<sub>H</sub> / 2197.1<sub>w</sub> x 698.5<sub>mmH</sub>

800.844.8877

Nomadic  Display®

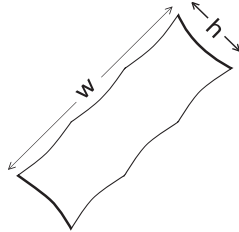
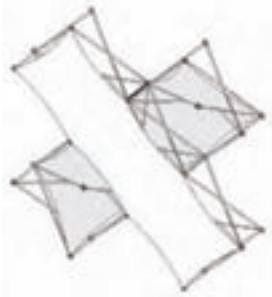
**Panel 22****3x1 Double Twist**

**Trim Size:** 86.5"<sub>w</sub> x 28"<sub>H</sub> / 2120.9<sub>w</sub> x 711.2mm<sub>H</sub>

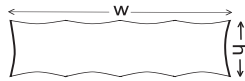
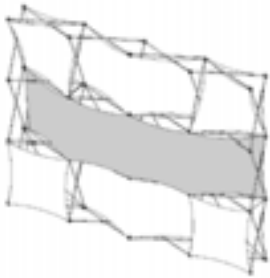
**Panel 23****4x1 Double Thread**

**Trim Size:** 112"<sub>w</sub> x 27.5"<sub>H</sub> / 2844.8<sub>w</sub> x 698.5mm<sub>H</sub>

## Instand<sup>®</sup> and Platinum<sup>®</sup> Integration - Heights and Widths

### Panel Height Options:

Instand<sup>®</sup> panels can now be ordered in two different heights depending on the look you are trying to achieve:

### Panel Height Options:

#### Option A:

Standard panel heights on Platinum and Instand integrated systems are 92.91"/2360mm high to match the Platinum system height. Stiffeners are applied to the back of the panel, so they are not exposed. Notches are required to be cut into graphic panel.

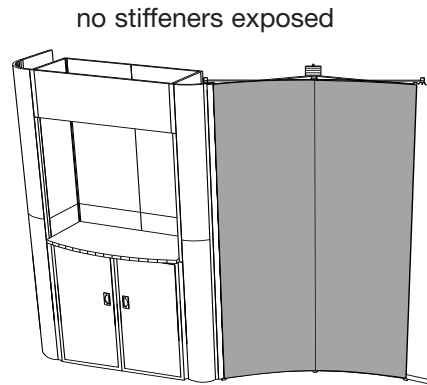

**A. Standard**

stiffeners exposed

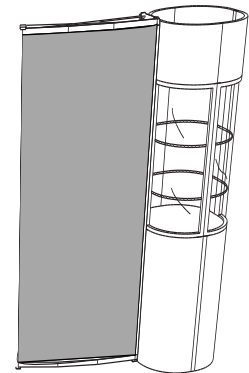

**B. Optional**

#### Option B:

Instand panels may be produced 89.76"/2280mm high with stiffeners exposed allowing them to integrate with existing Instand panels.

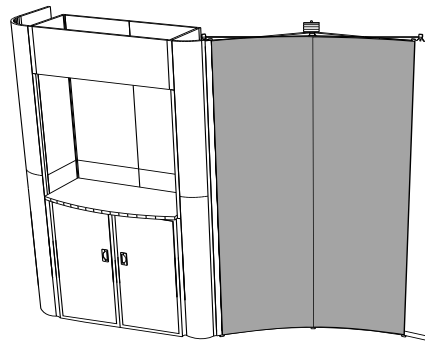

**A. With Filler**

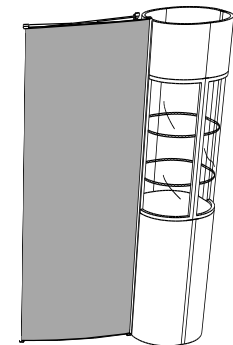

**B. Without Filler**

### Panel Width Options:

#### Option A:

You may produce the Instand panel that connects to the Platinum panel as a standard, classic width. The advantage is that when the end user wants to use the Instand by itself, the panel fits the frame. However, when it connects to Platinum a filler strip is required.

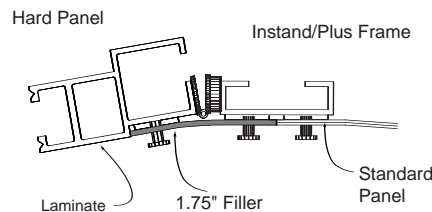

**A. With Graphic Filler**

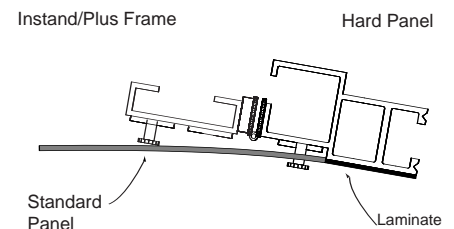

**B. Without Graphic Filler**

FPF3SH - See Page 18

### GRAPHIC GUIDELINES

#### Front-Mount Backlit Graphic

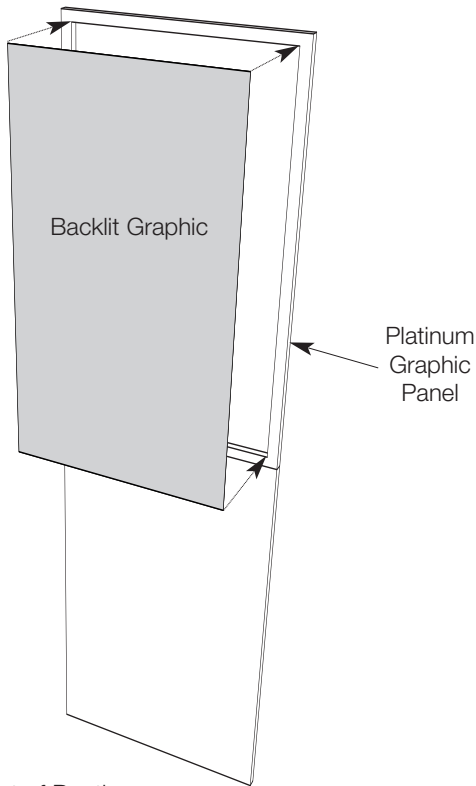

Front of Booth

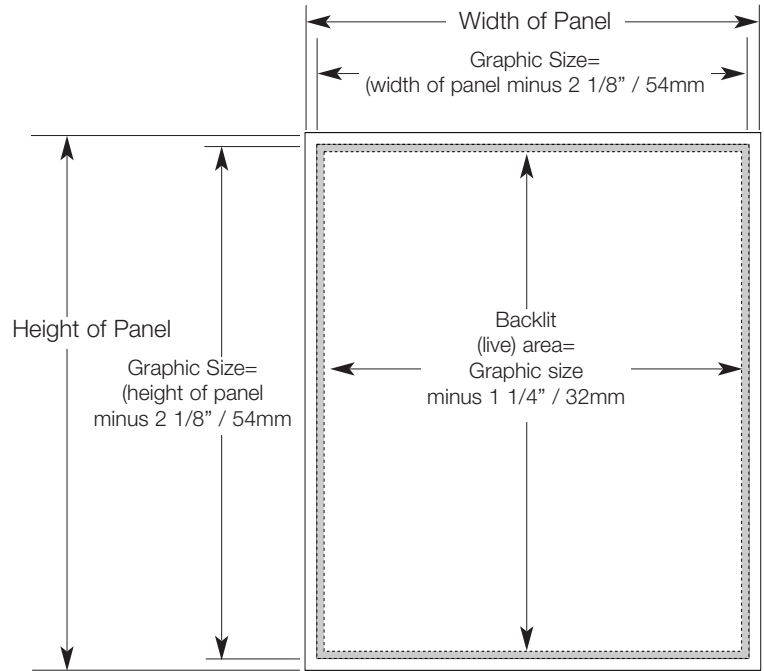

Backlit graphics are to be attached to the front side of Platinum panels, using a hook-and-loop tape connection. Hook tape (1/2" width) is to be mounted to the rear of the graphic, 1/16" in from the edge of the graphic. The graphic is then applied to the front of the Platinum panel.

Graphic size is calculated by subtracting 2 1/8" (54mm) from the height and width of panel dimensions. Backlit 'live' area is calculated by subtracting 1 1/4" (32mm) from the graphic size.

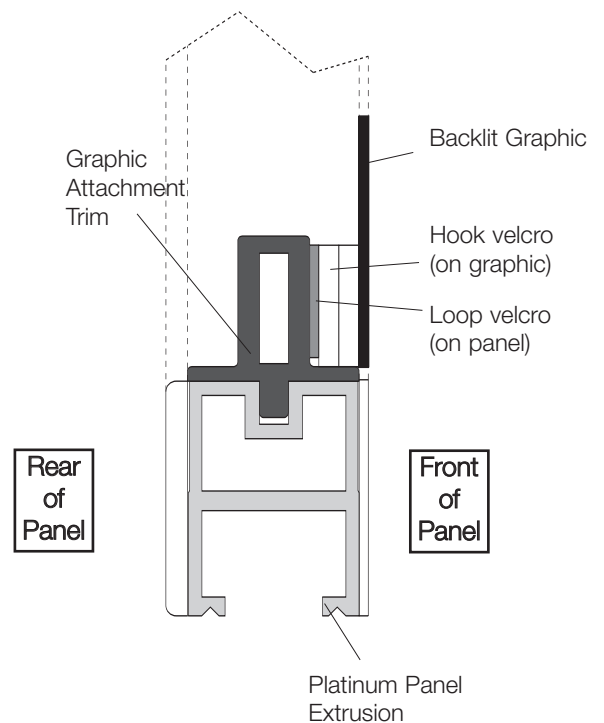



## Detachable Backlit Bridge/Header Graphic

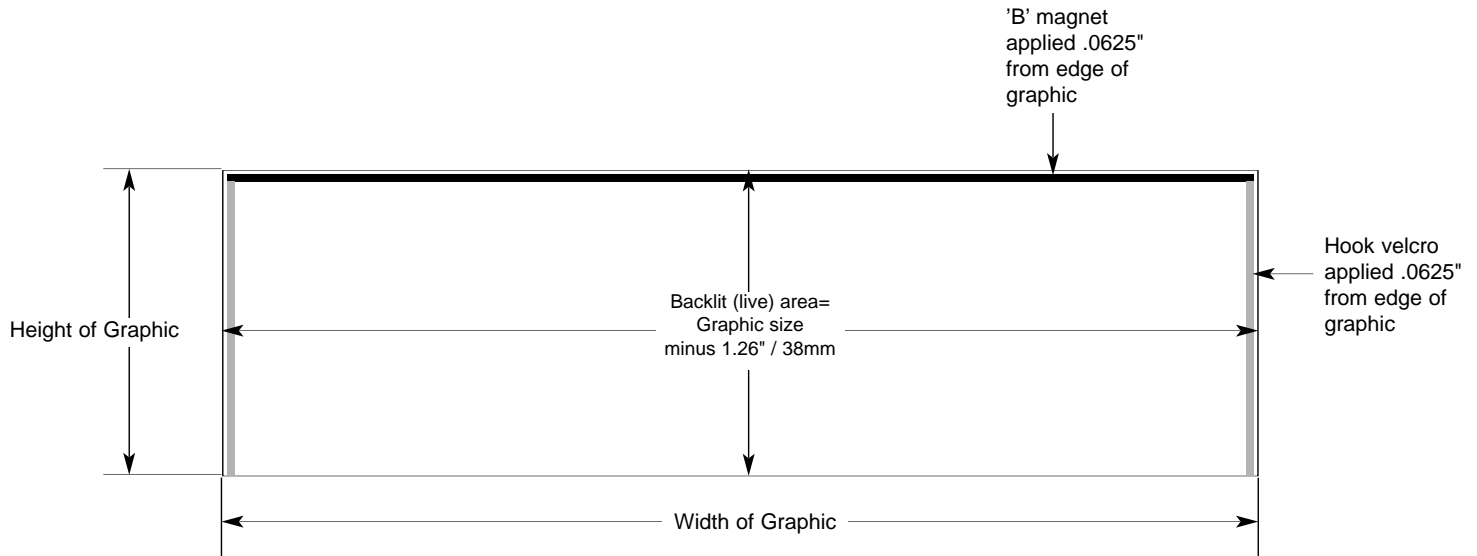

These graphics are to be attached to the milk plexi substrate on the face of a backlit bridge or header assembly.

Hook tape and "B" magnet (.5" width) are to be mounted to the rear of the graphic,  $.0625"$  in from the edge of the graphic.

Hook tape is applied in the height dimension, and "B" magnet is applied at the **top of the graphic only** in the width dimension.

The lower edge of the graphic mounts into a clear channel on the frame, and no attachment is required.

## GRAPHIC GUIDELINES

Headers:

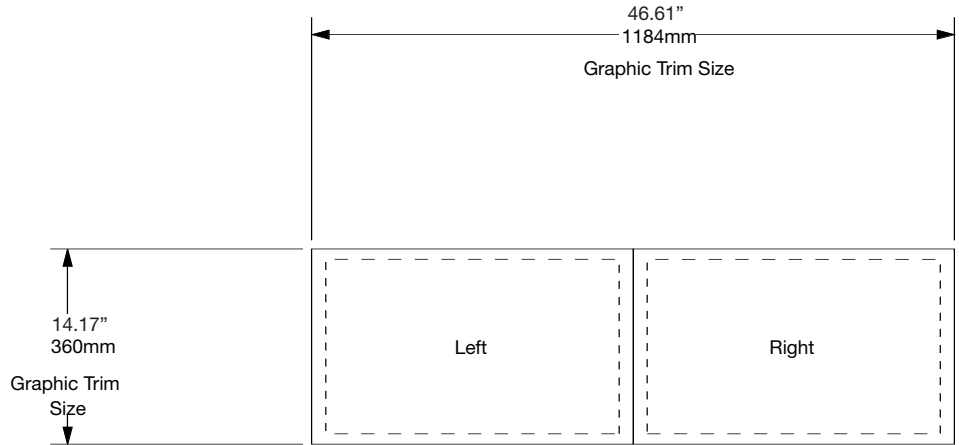
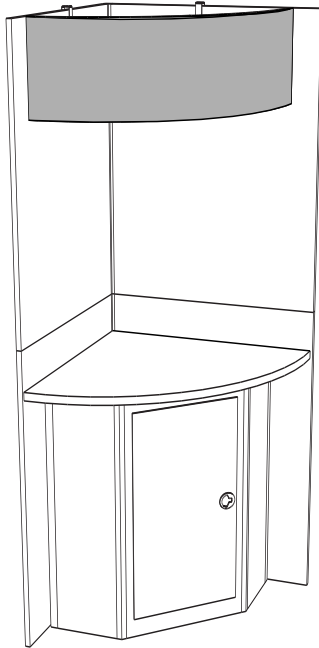

Curved Header for Quarter Round Alcove

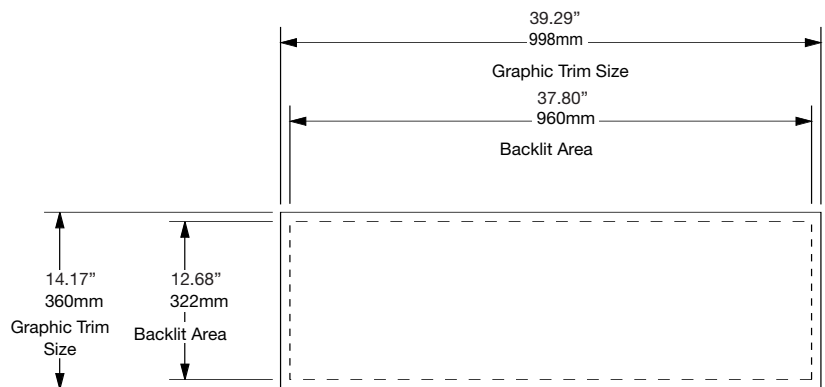
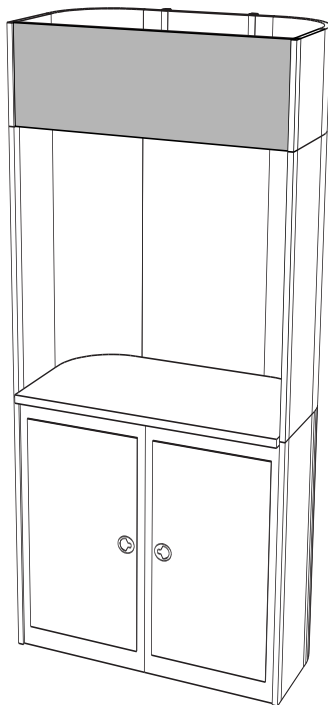

Flat Header for Rounded Alcove

## GRAPHIC GUIDELINES

Headers (cont):

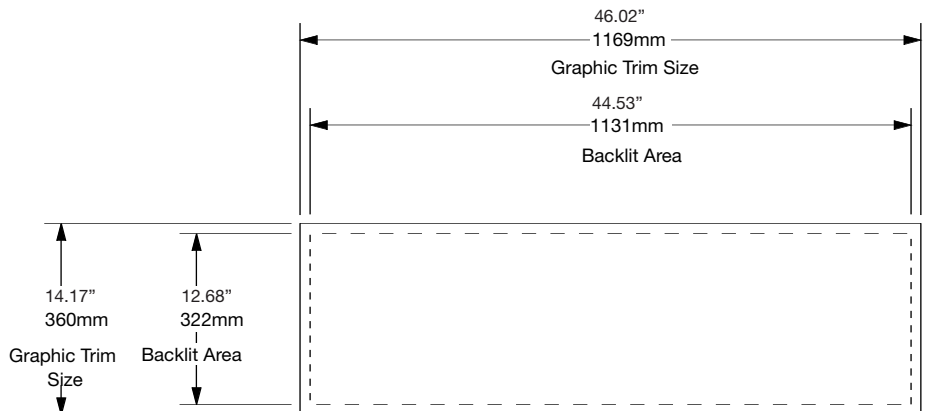
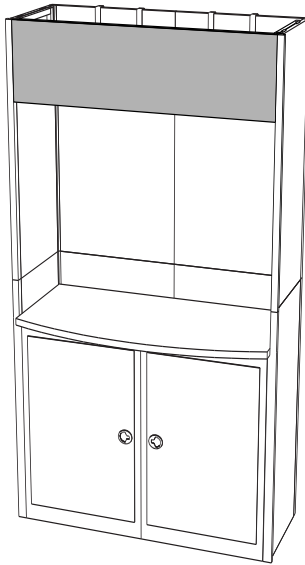

Flat Header for Rectangular Alcove

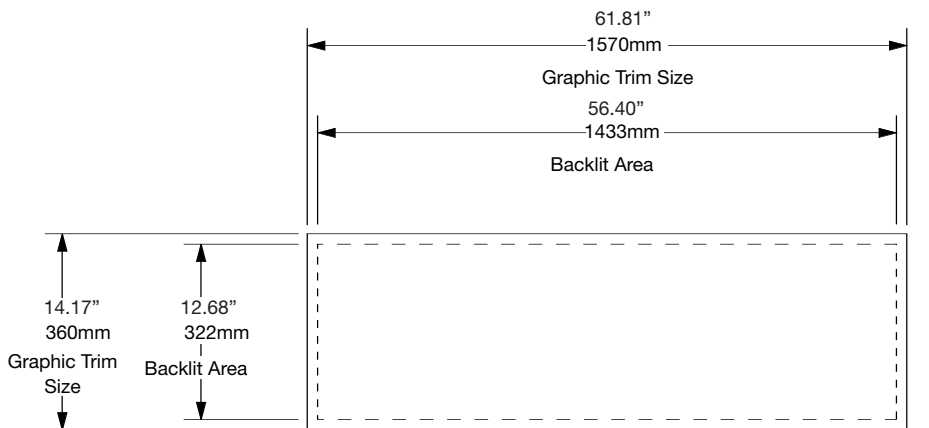
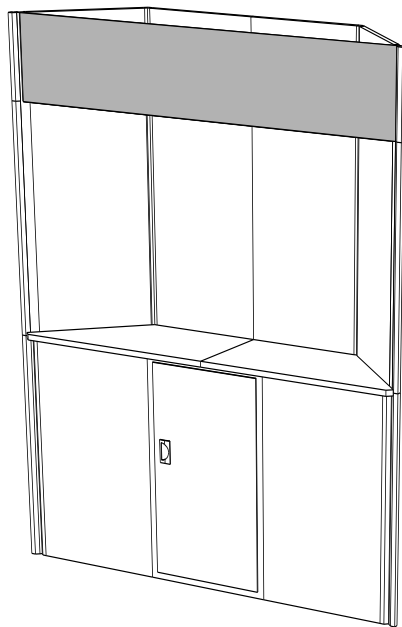

Flat Header for Trapezoidal Alcove

## GRAPHIC GUIDELINES

Showcase Bridge - 65.190/1656mm Wide

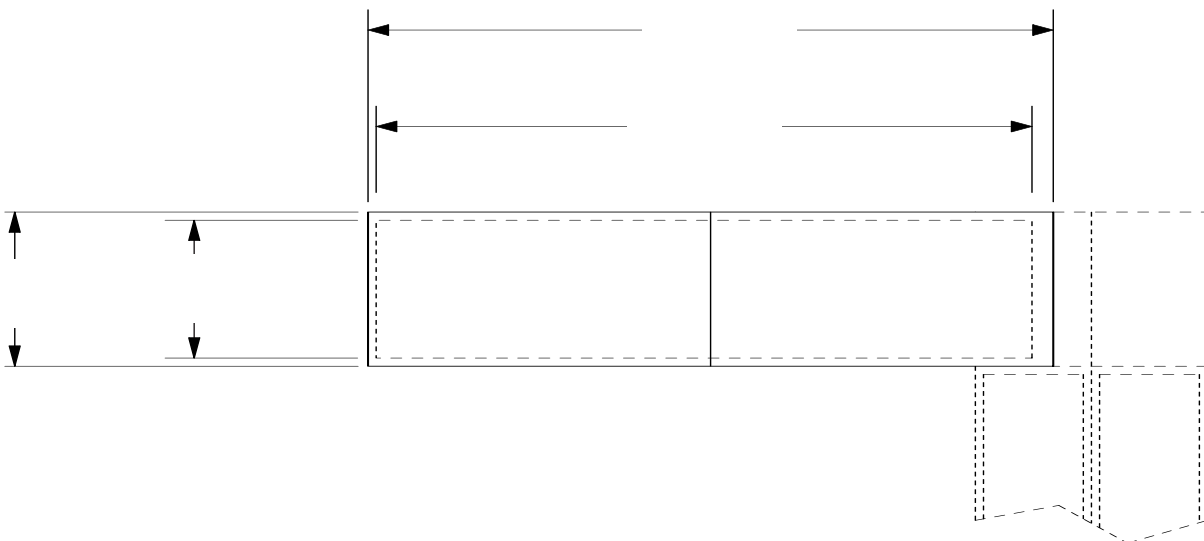
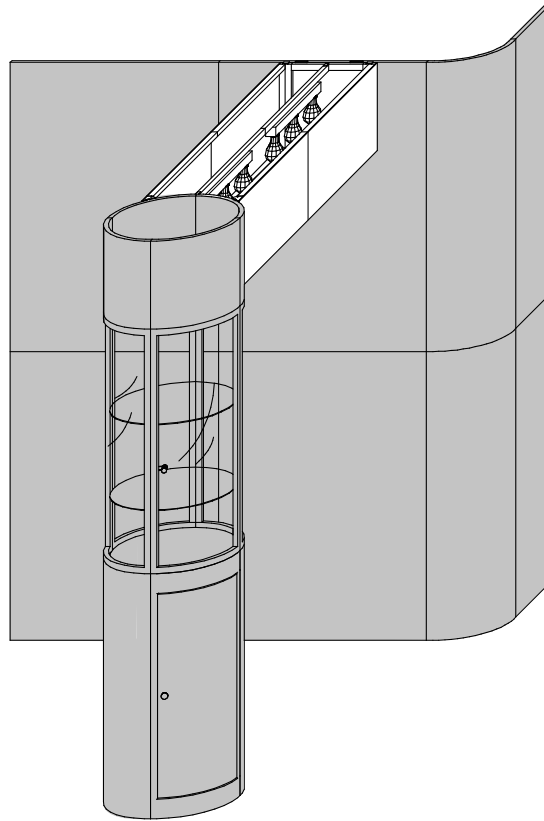

**Note: Bridge panels ship with unmounted milk plexi unless otherwise requested.**

## GRAPHIC GUIDELINES

Bridges - 55.12"/1400mm Wide

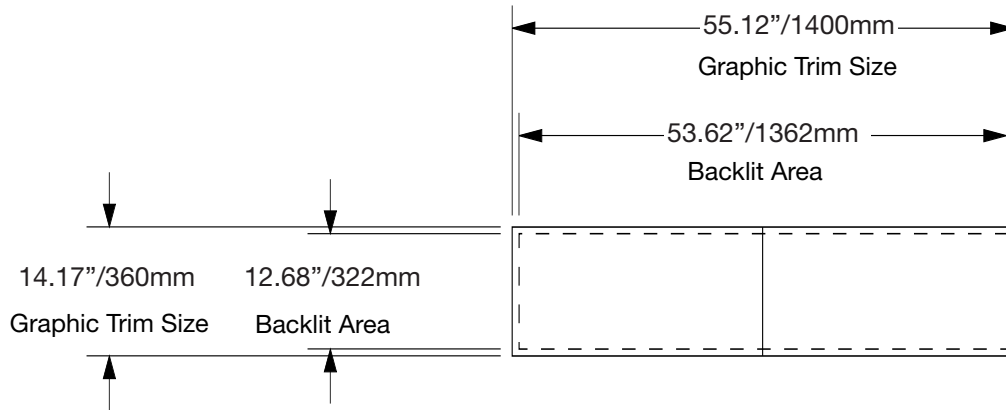
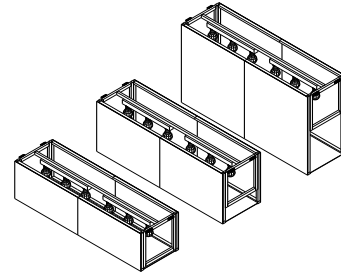

**Square Bridge - 55.12"Ø1400mmW x 14.17"Ø360mmH**

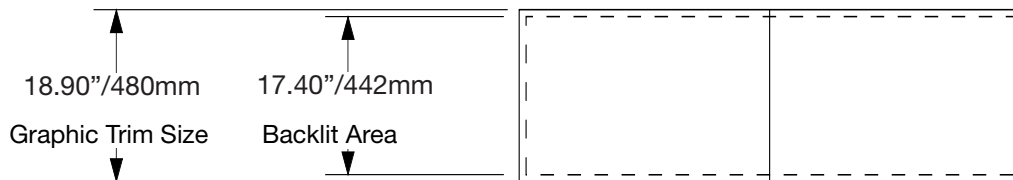

**Square Bridge - 55.12"Ø1400mmW x 18.90"Ø480mmH**

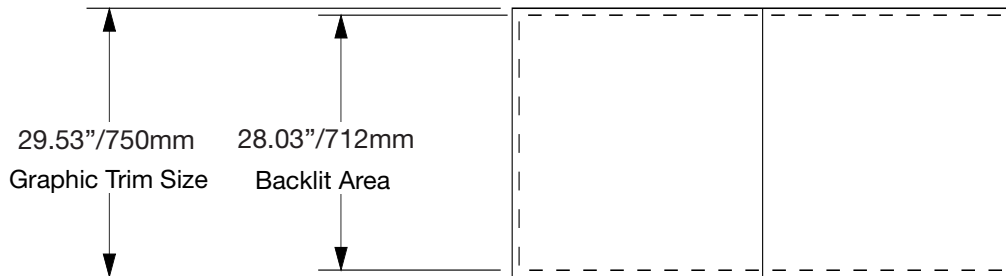

**Square Bridge - 55.12"Ø1400mmW x 29.53"Ø750mmH**

## GRAPHIC GUIDELINES

Bridges - 62.99"/1600mm Wide

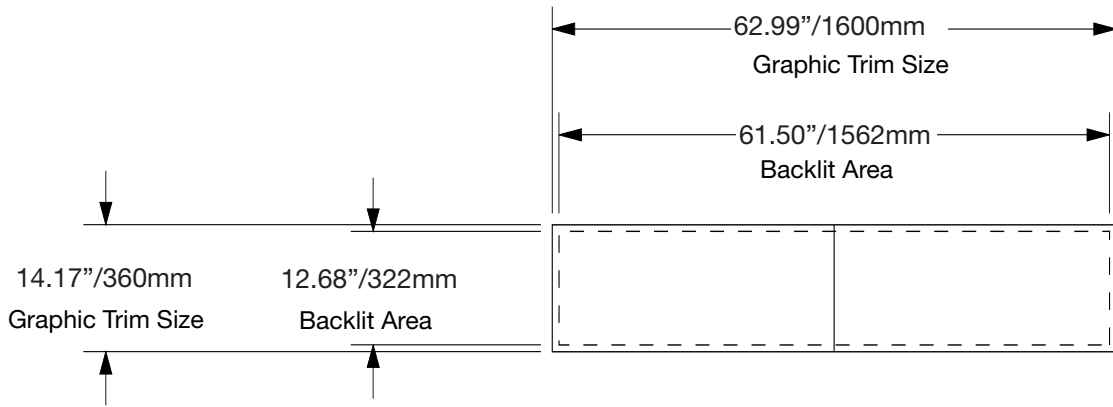
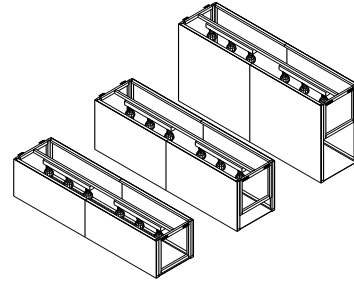

**Square Bridge - 62.99"±1600mmW x 14.17"±360mmH**

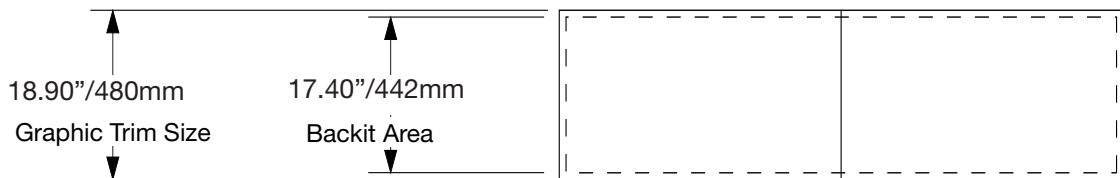

**Square Bridge - 62.99"±1600mmW x 18.90"±480mmH**

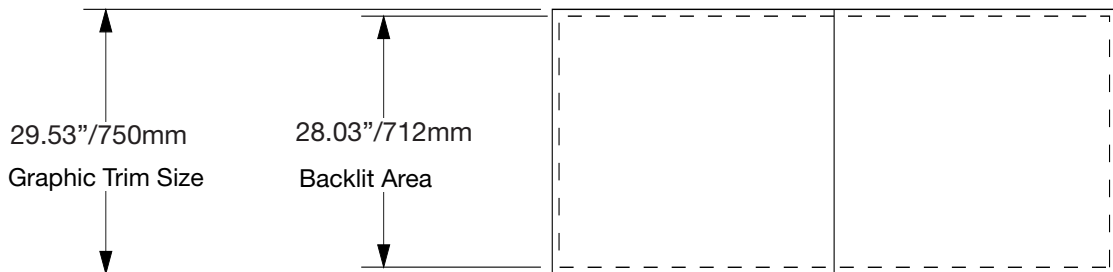

**Square Bridge - 62.99"±1600mmW x 29.53"±750mmH**

### GRAPHIC GUIDELINES

Bridges - 66.93"/1700mm Wide

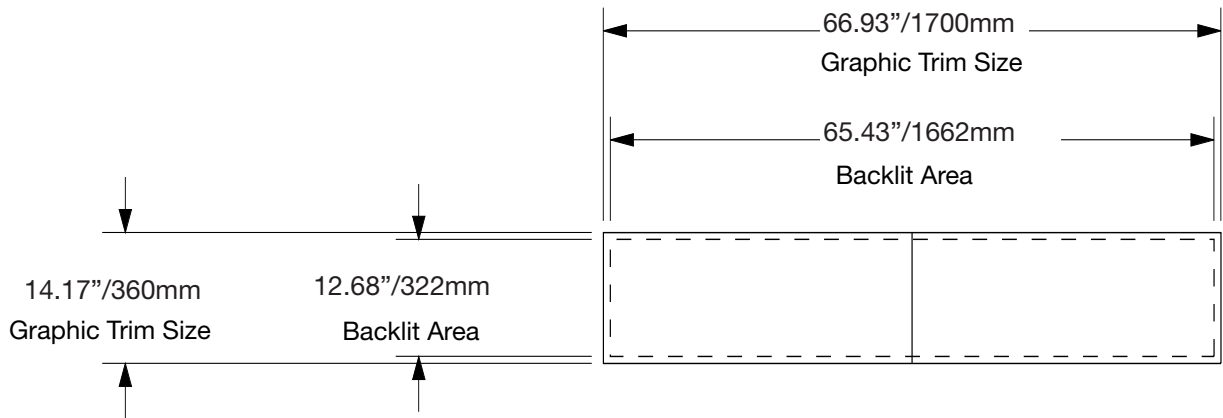
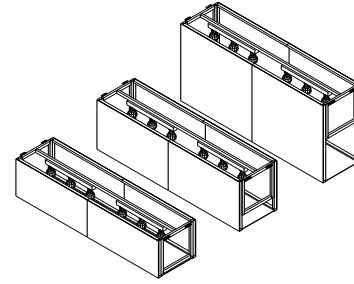

**Square Bridge - 66.93"Ø1700mmW x 14.17"Ø360mmH**

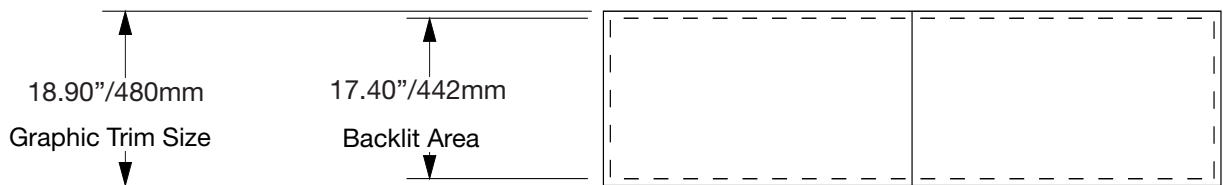

**Square Bridge - 66.93"Ø1700mmW x 18.90"Ø480mmH**

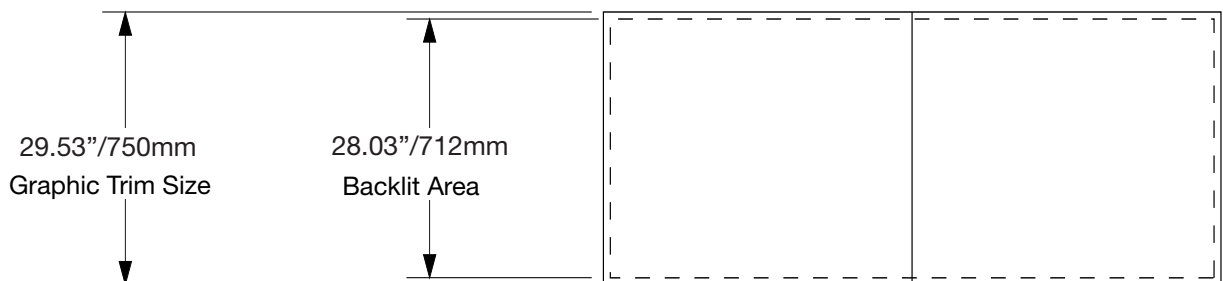

**Square Bridge - 66.93"Ø1700mmW x 29.53"Ø750mmH**

### GRAPHIC GUIDELINES

Bridges - 72.83"/1850mm Wide

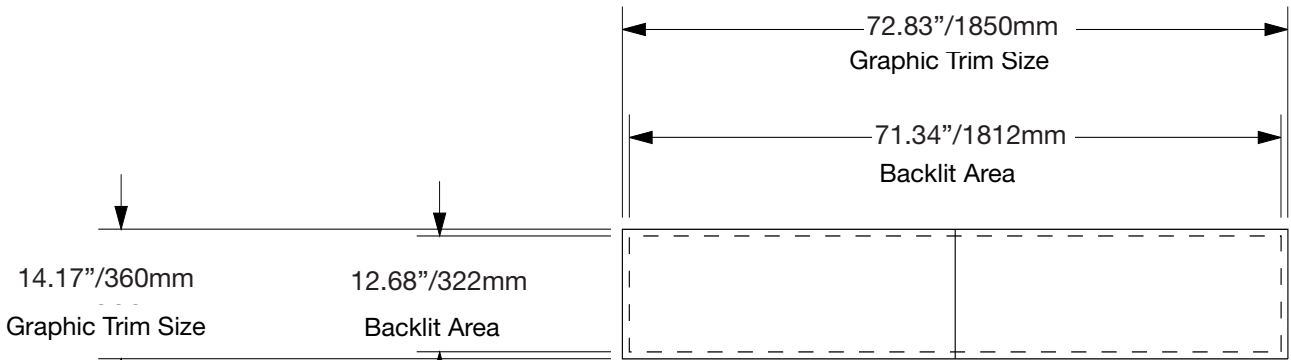
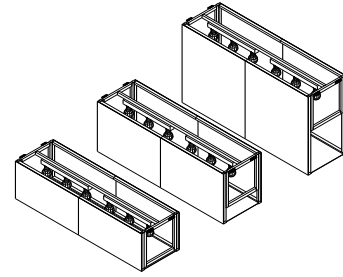

**Square Bridge - 72.83"Ø1850mmW x 14.17"Ø360mmH**

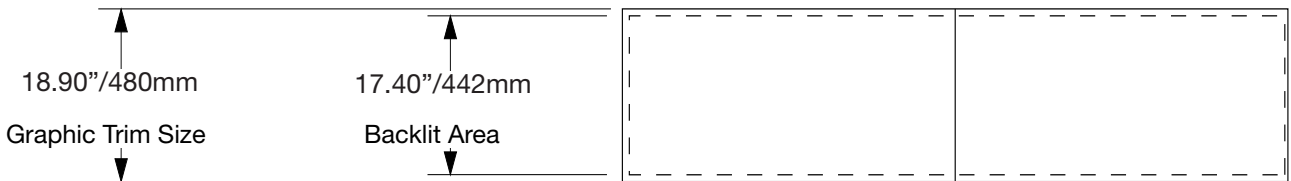

**Square Bridge - 72.83"Ø1850mmW x 18.90"Ø480mmH**

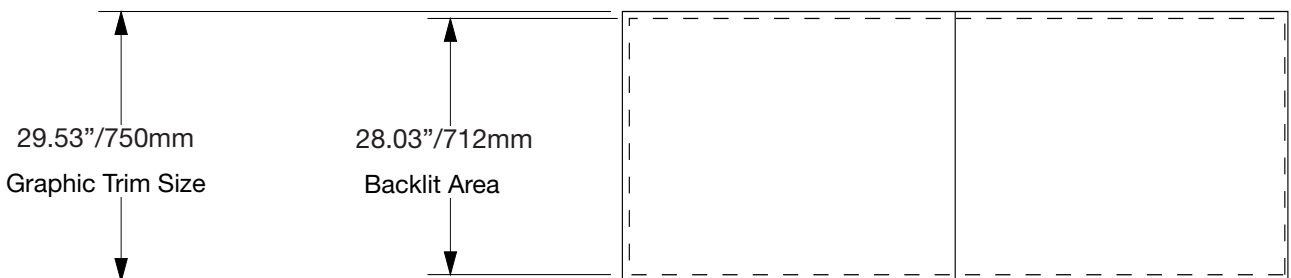

**Square Bridge - 72.83"Ø1850mmW x 29.53"Ø750mmH**



### GRAPHIC GUIDELINES

Bridges - 78.740/2000mm Wide

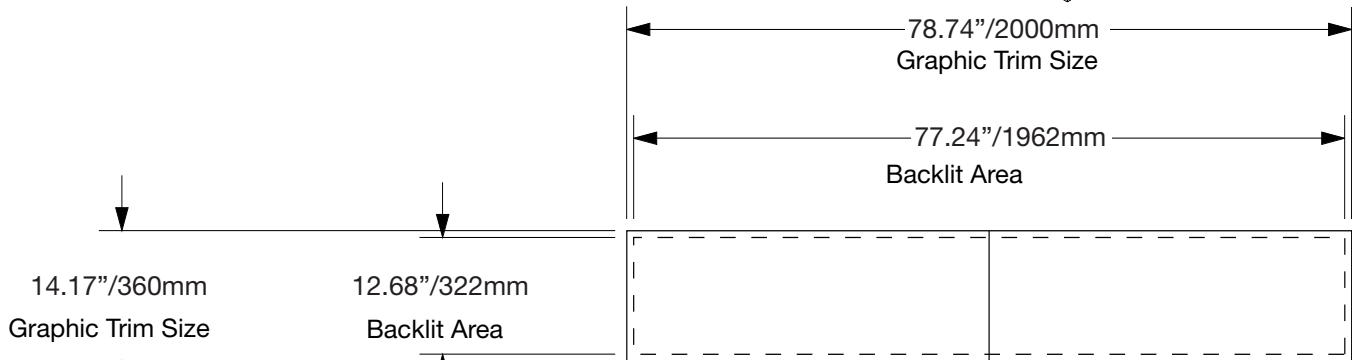
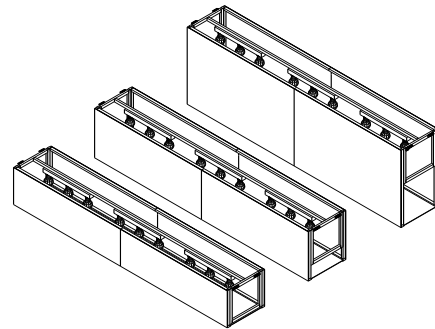

**Square Bridge - 78.740/2000mmW x 14.170/360mmH**

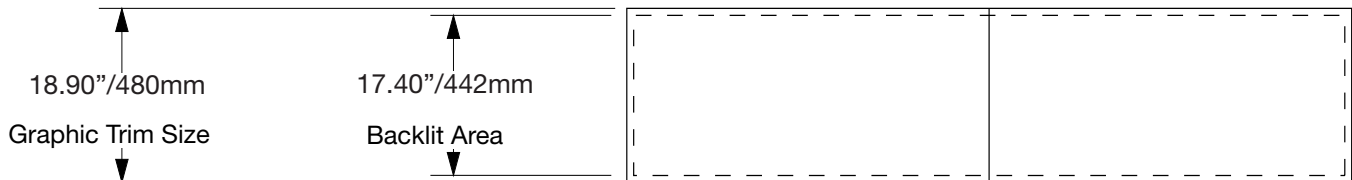

**Square Bridge - 78.740/2000mmW x 18.900/480mmH**

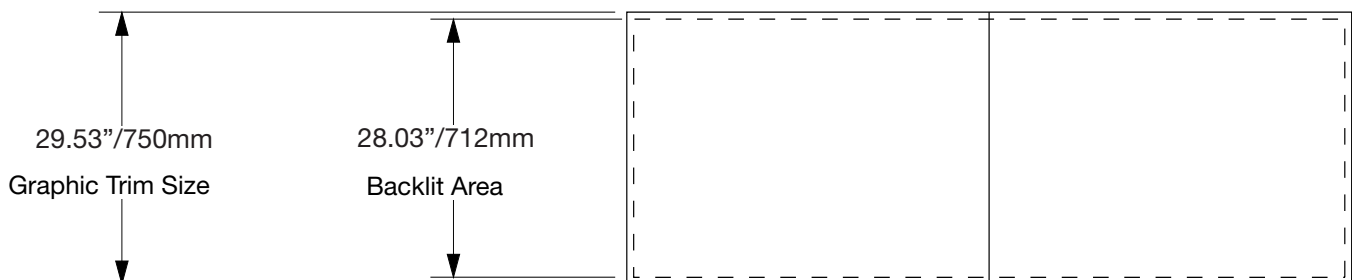

**Square Bridge - 78.740/2000mmW x 29.530/750mmH**

## GRAPHIC GUIDELINES

Bridges - 118.110/3000mm Wide

118.11"/3000mm

116.61"/2962mm

14.17"/360mm    12.68"/322mm

**Square Bridge - 118.110/3000mmW x 14.170/360mmH**

18.90"/480mm    17.40"/442mm

**Square Bridge - 118.110/3000mmW x 18.900/480mmH**

29.53"/750mm    28.03"/712mm

**Square Bridge - 118.110/3000mmW x 29.530/750mmH**

## Example of Stiffener and Magnet Mounting (with stiffeners hidden)

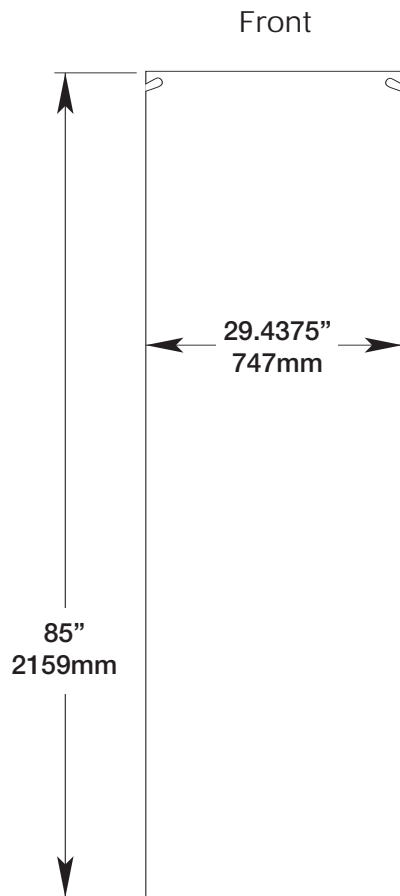

Fig. 1

Apply 25mm double backed adhesive tape to top and bottom.

Attach top and bottom stiffeners to the back of the panel so that they are not visible from the front.

Notches must be cut in graphic face for hanging.

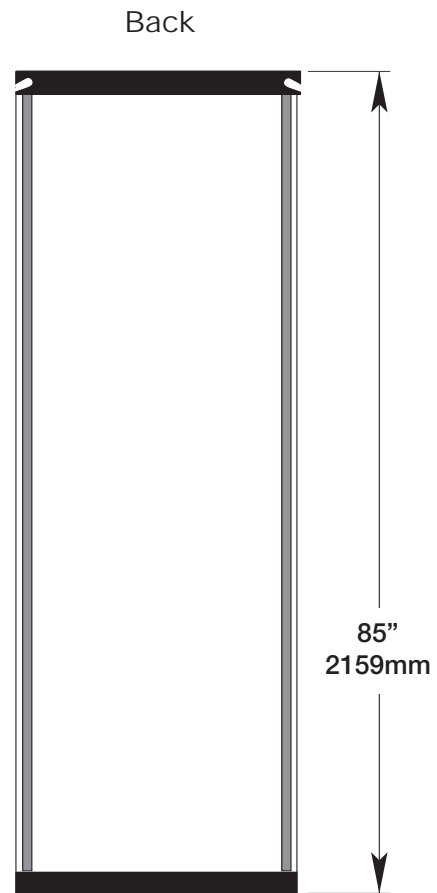
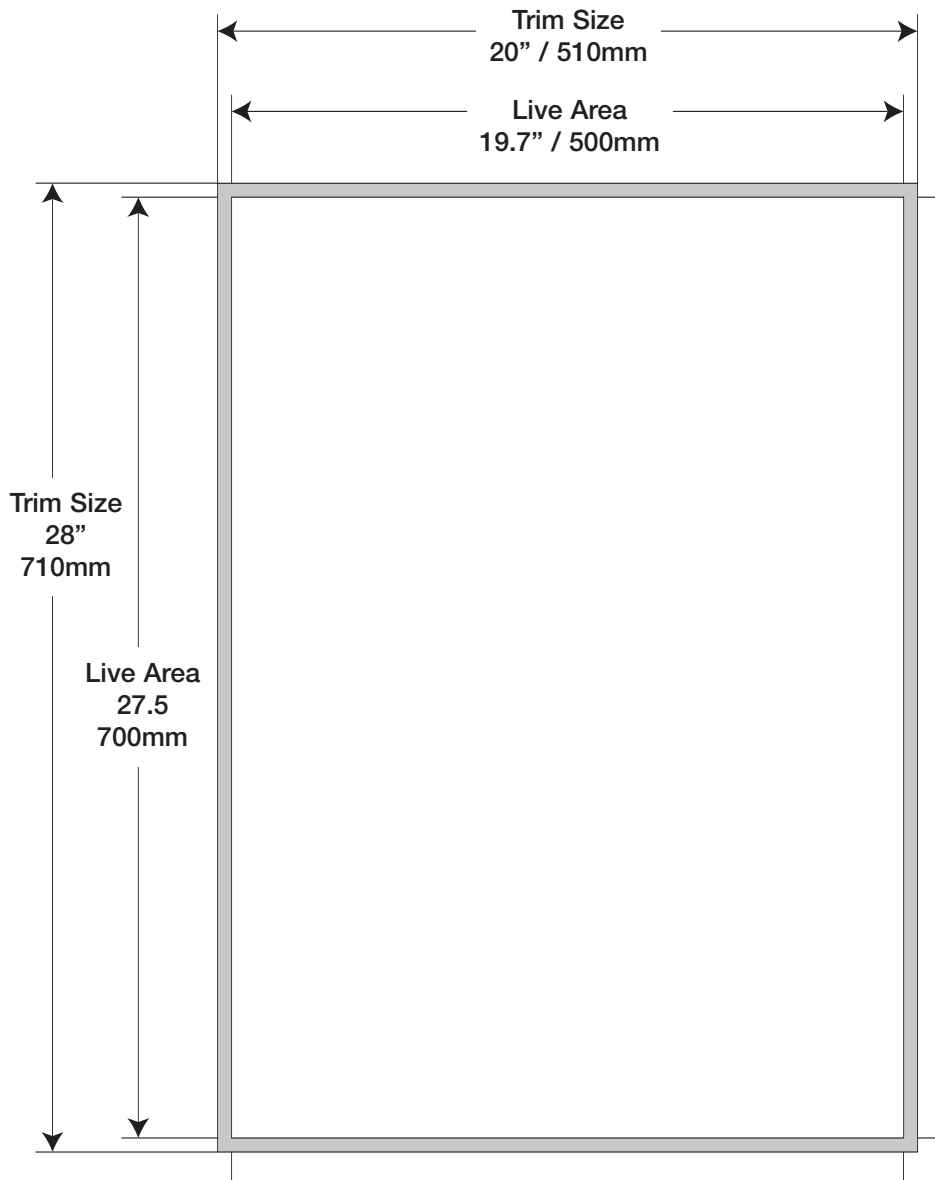
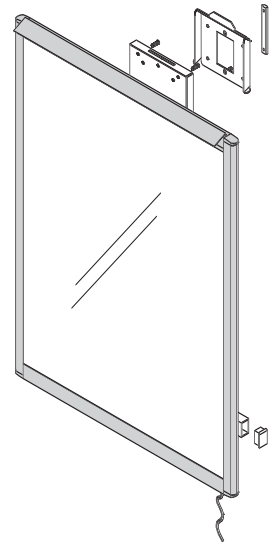

Fig. 2

Apply magnetic tape 1.5mm from outer edges

## LightBox Specifications



### Graphic Material

The recommended thickness of transparent or translucent graphic material is 0.1 to 0.3 mm

## Example of Velcro Mounting

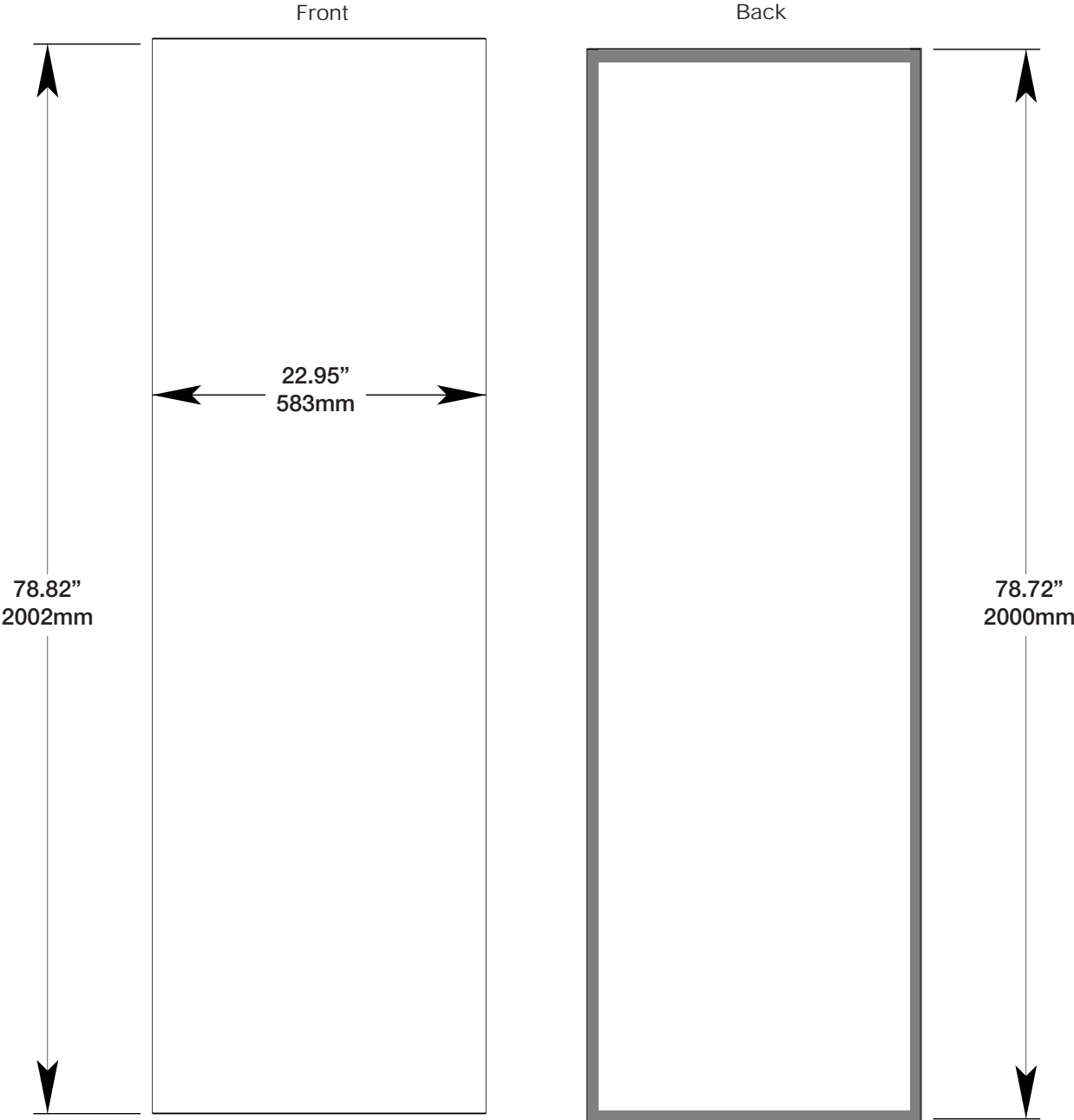

Back Side  
Apply .5" hook  
velcro to rear edges

## Graphic Specifications: Finials

### Standard

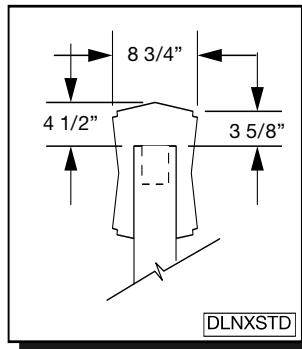
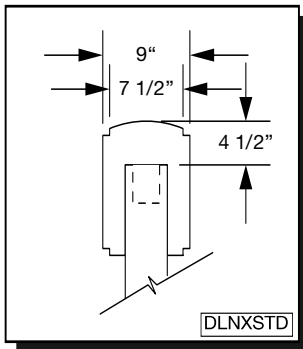
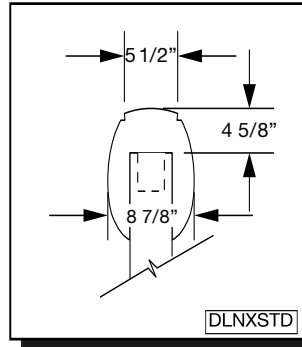
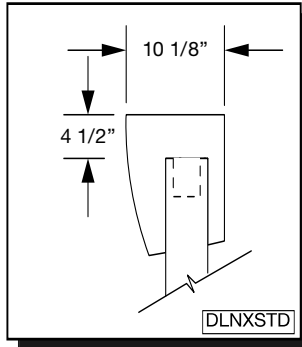
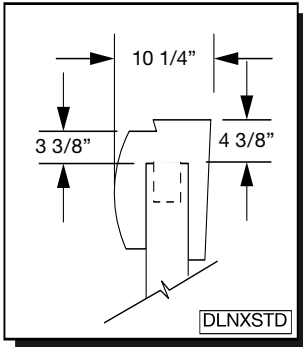

- Dimensions shown are to be used as a guideline when creating your graphics.
- It is assumed that graphics will be adhesive vinyl or similar first-surface application.
- Surfaces shown will be finished in high-pressure plastic laminate, any additional preparations for graphic application must be made by the purchaser.

### Optional

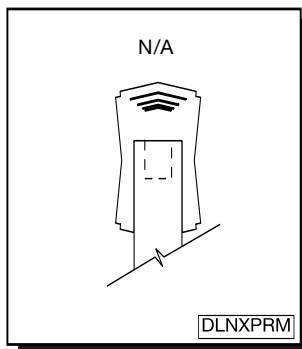
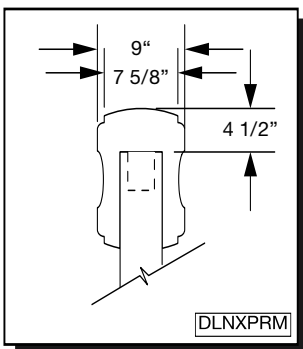
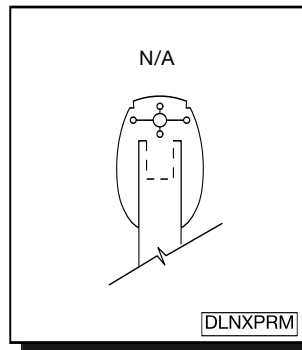
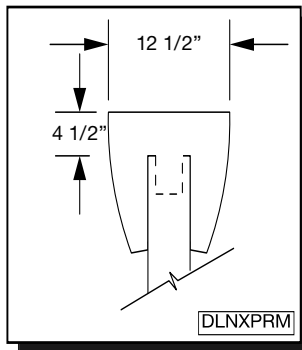
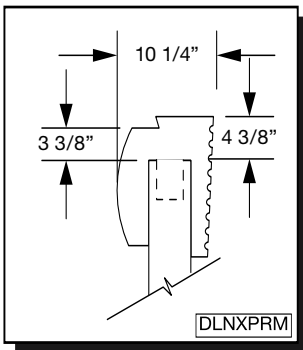

- Dimensions shown are to be used as a guideline when creating your graphics.
- It is assumed that graphics will be adhesive vinyl or similar first-surface application.
- Surfaces shown will be finished in high-pressure plastic laminate, any additional preparations for graphic application must be made by the purchaser.

## Graphic Specifications: Standard Fascia

### Standard

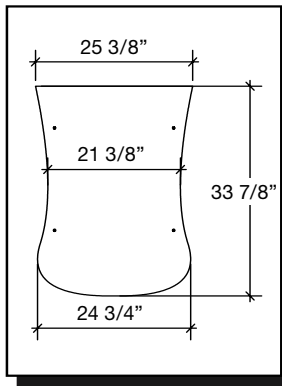
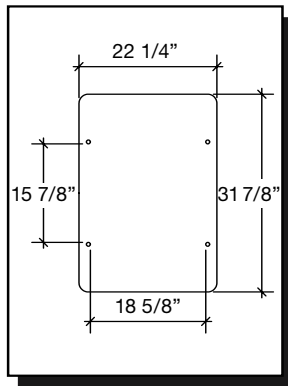
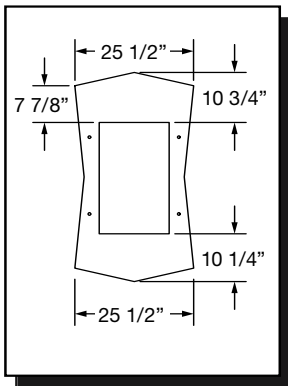
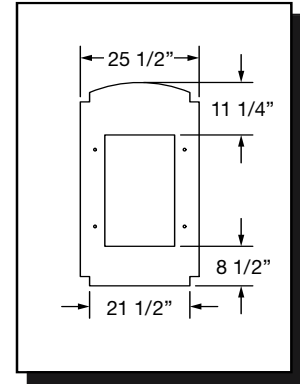
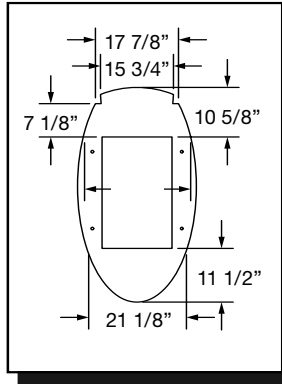
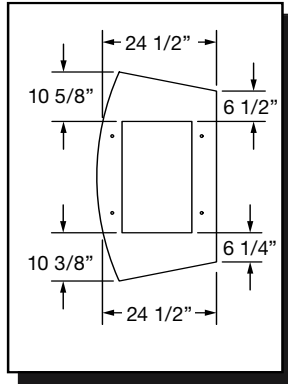
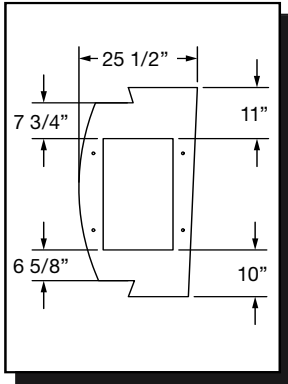

- Dimensions shown are to be used as a guideline when creating your graphics.
- It is assumed that graphics will be adhesive vinyl or similar first-surface application.
- Surfaces shown will be finished in high-pressure plastic laminate, any additional preparations for graphic application must be made by the purchaser.

## Graphic Specifications: Optional Fascia

### Optional

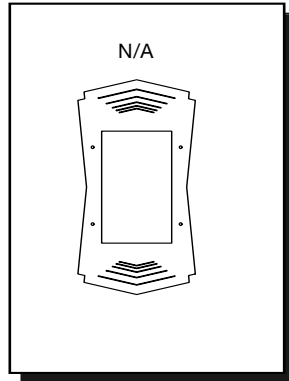
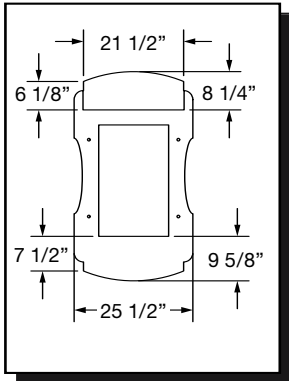
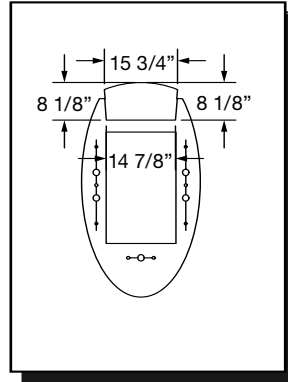
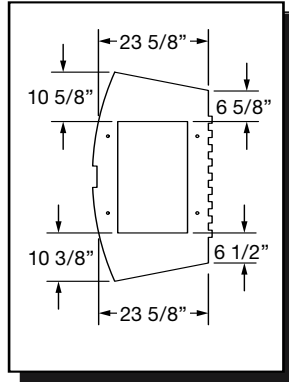
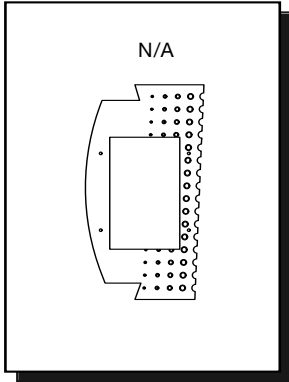

- Dimensions shown are to be used as a guideline when creating your graphics.
- It is assumed that graphics will be adhesive vinyl or similar first-surface application.
- Surfaces shown will be finished in high-pressure plastic laminate, any additional preparations for graphic application must be made by the purchaser.



## Matisse, Pollock, Reubens

Magnetic Panels (with stiffeners hidden)

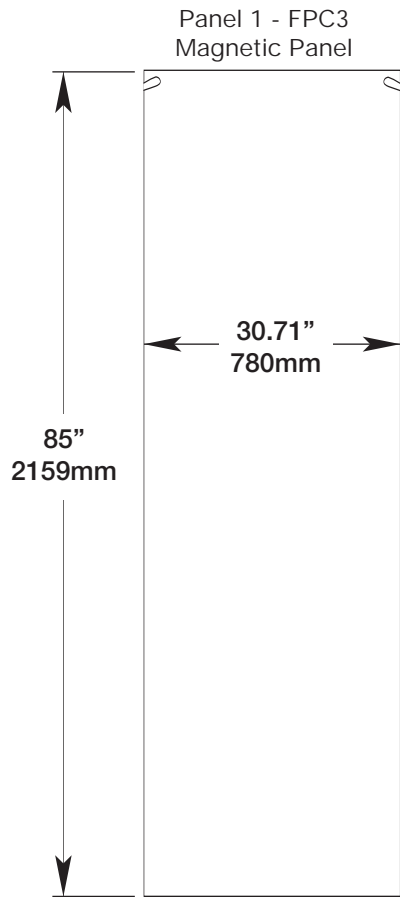

Stiffeners: **GSPLB, GSPLT**

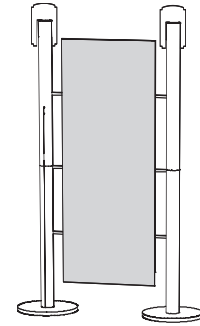

Matisse  
Single-Sided: Panel 1 (x1)  
Double-Sided: Panel 1 (x2)

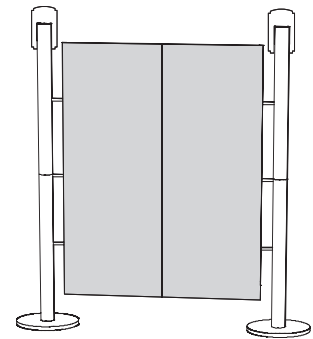

Pollock  
Single-Sided: Panel 1 (x2)  
Double-Sided: Panel 1 (x4)

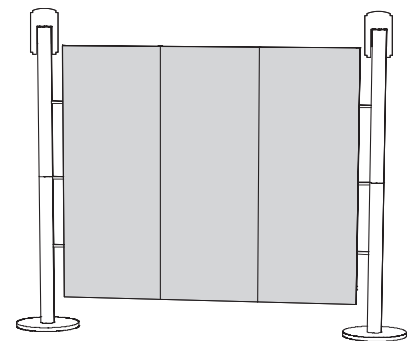

Reubens  
Single-Sided: Panel 1 (x3)  
Double-Sided: Panel 1 (x6)

\* Note: For double-sided configurations, panel measurements are the same.

## Escher

**Magnetic Panels**  
**(with stiffeners hidden)**

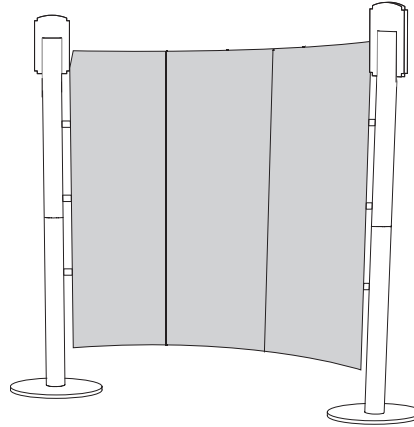

Panel 1 - Concave  
Magnetic Panel (x3)

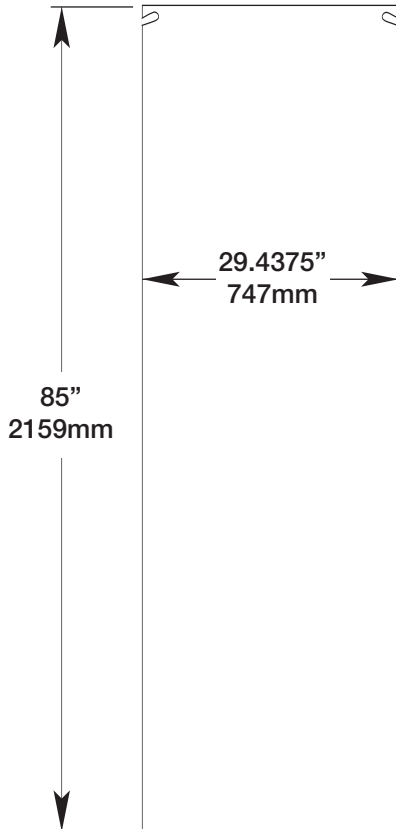

**Stiffeners: GSCLT, GSCLB**

Convex Magnetic Panel (x3)  
for Double-Sided Escher Kit

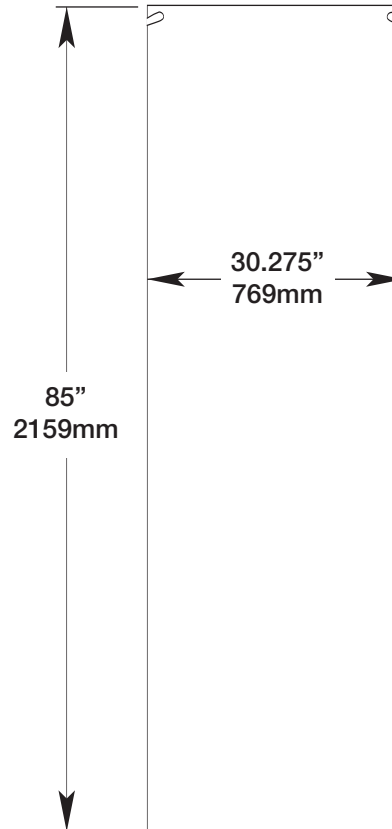

**Stiffeners: GSDLBT1, GSDLTP1**

# Titian

## Magnetic Panels (with stiffeners hidden)

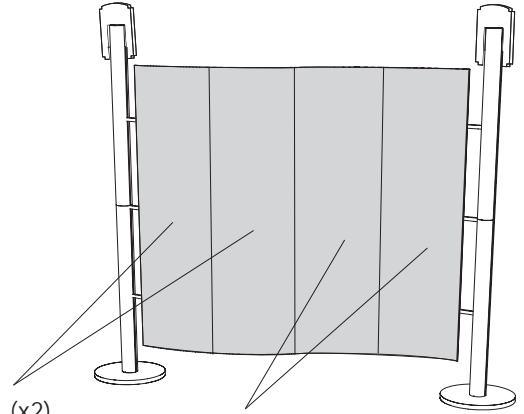

Single-Sided: Panel 1 (x2)  
Double-Sided: Panel 1 (x4)

Single-Sided: Panel 2 (x2)  
Double-Sided: Panel 2 (x4)

Panel 1 - Convex  
Magnetic Panel (x2)

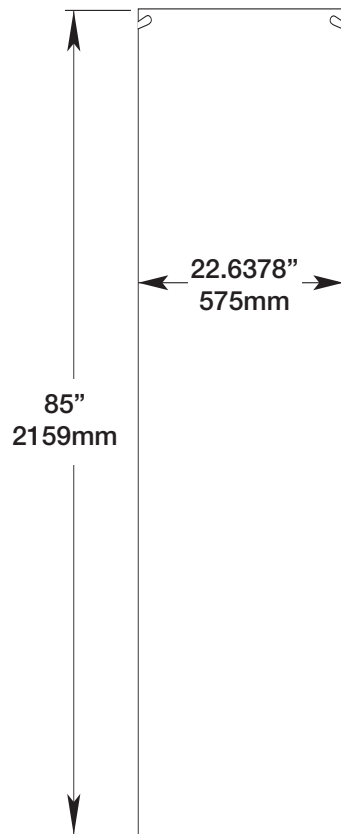

**Stiffeners: Y-GSCXT, Y-GSCXB**

Panel 2 - Concave  
Magnetic Panel (x2)

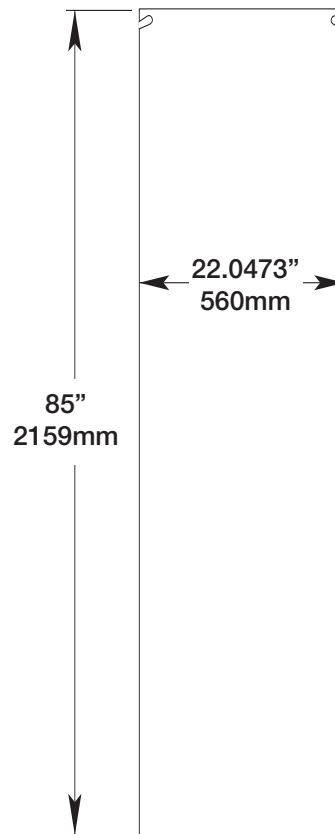

**Stiffeners: Y-GSCVT, Y-GSCVB**

\* Note: For double-sided configurations, panel measurements are the same.

## Degas Velcro® Panels

Front

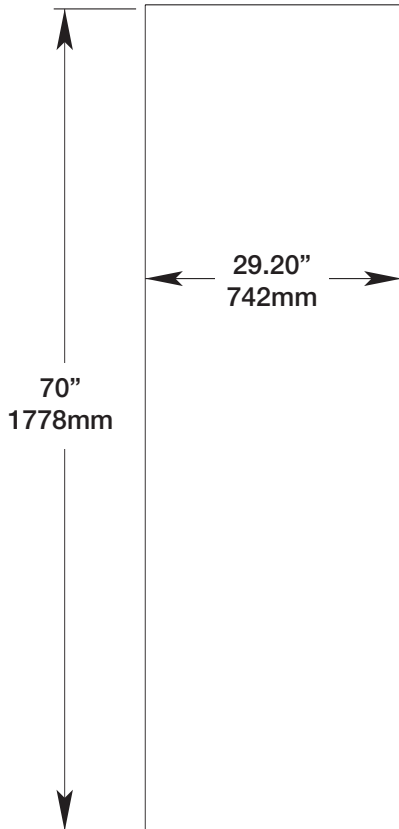

Back

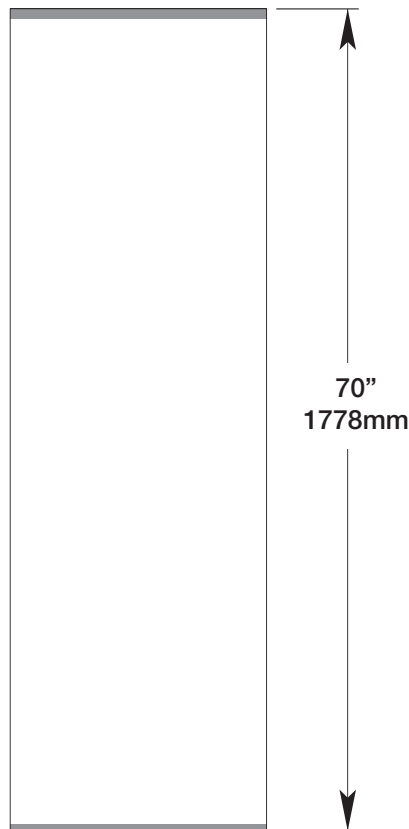

Apply magnets to inside back edges for vertical seam alignment

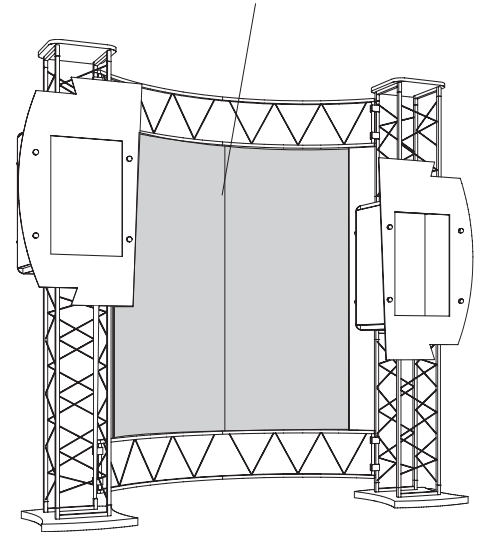

### Back Side

Apply .75" hook velcro to top and bottom.  
Edge magnets may be used to align panels.

### Backlit Graphic Option in DesignLine Cube

Back

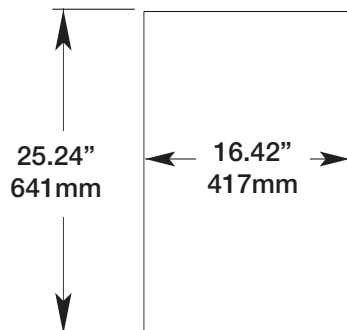

Front

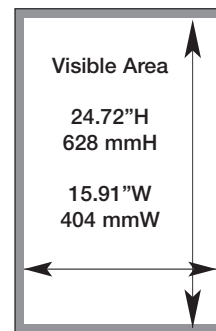

### Front Side

Apply .25 hook velcro to front edges

## Picasso

### Instand and Fabric Panels

Panel 1 - FEU3LF  
Instand Plus Flat Endcap

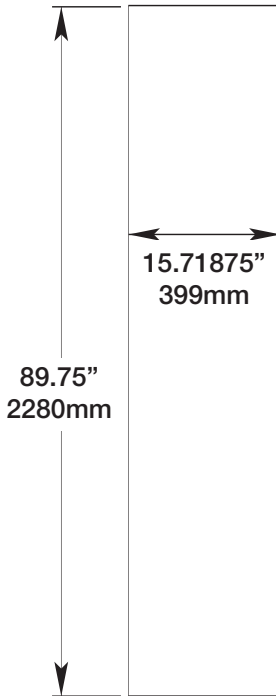

**Stiffeners: GSLFT, GSLFB**

Panel 2 - FPC3  
Instand Plus Panel (x2)

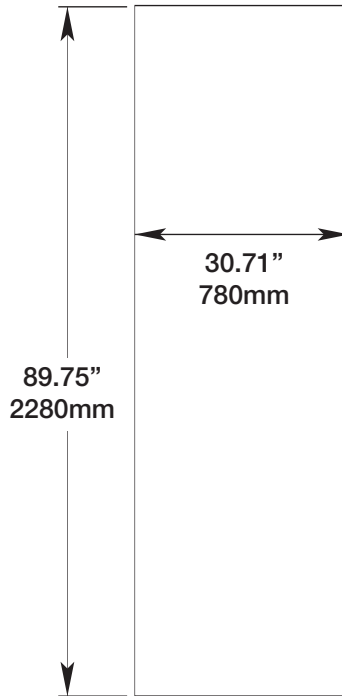

**Stiffeners: GSPLB, GSPLT**

Panel 4 - Tension Fabric\*

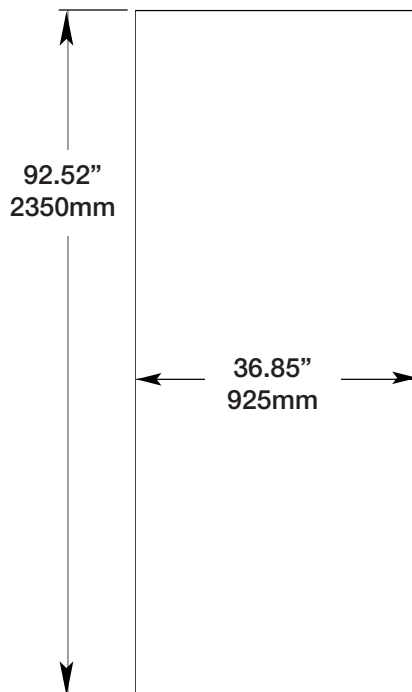

Panel 5 - Tension Fabric\*

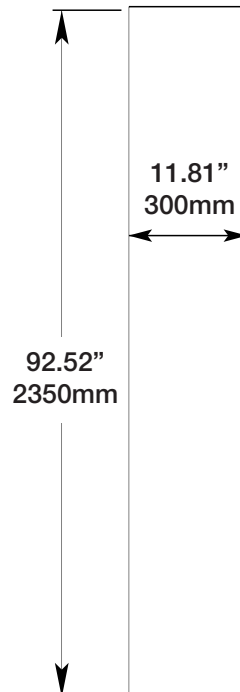

\*Image area only.  
Add 4" bleed to pole-pocket edges,  
and 2" bleed to hemmed edges.

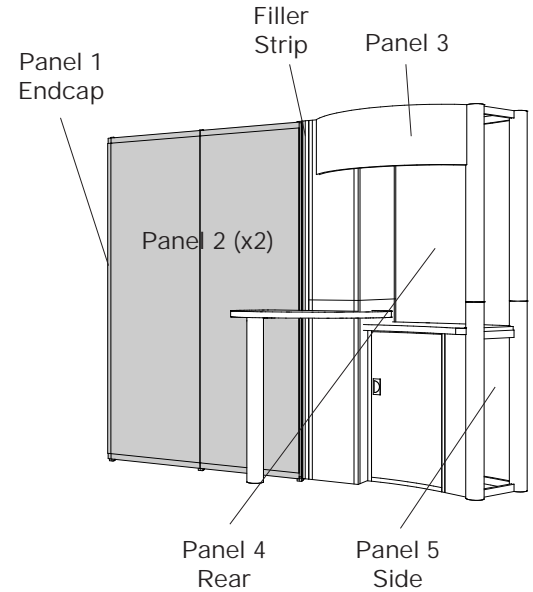

Panel 3 - Velcro Panel

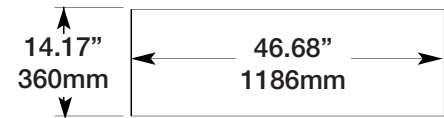

Filler Strip - FPP3SH  
attaches to  
inside edge

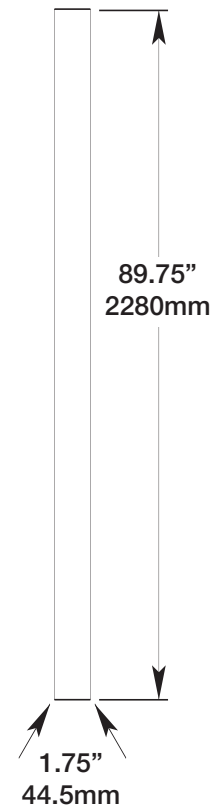

## Rembrandt

Magnetic Panels (with stiffeners hidden)

Sculpted Panels

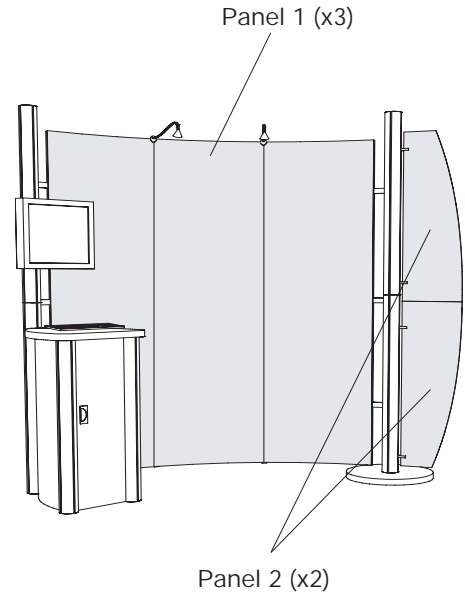

Panel 1 - FPC3  
Magnetic Panel (x3)

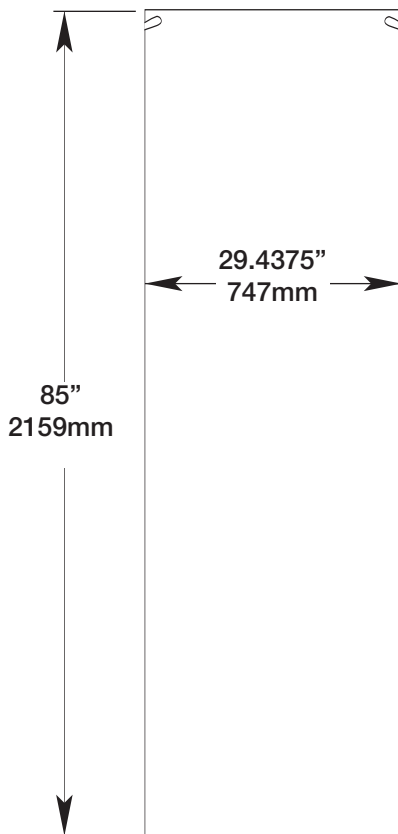

Stiffeners: GSCLT, GSCLB

Panel 3 (x2) - Laminate Panel for vinyl application  
(Templates available - Contact Solutions Studio)

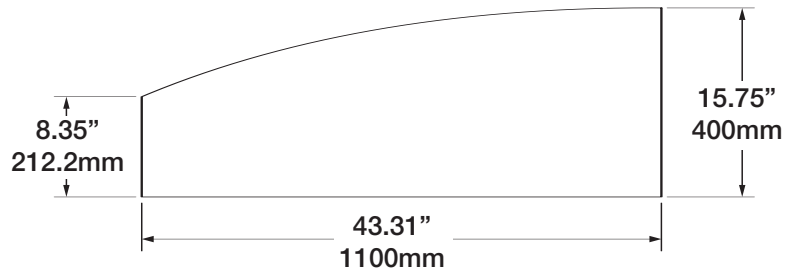

## Warhol

Instand Panels (with stiffeners hidden)

Sculpted Panels

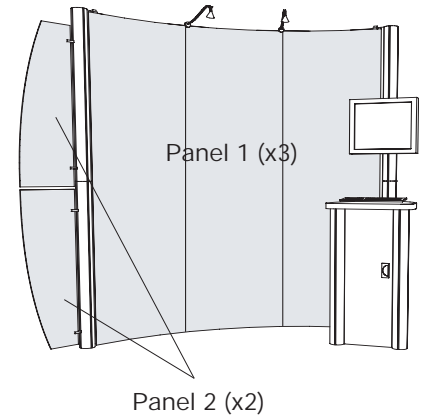

Panel 1 - FPC3  
Instand Classic Panel (x3)

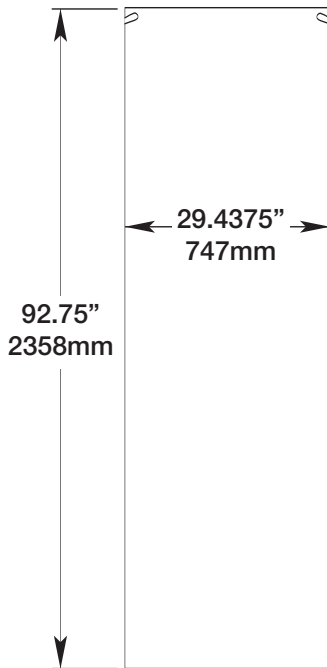

Stiffeners: GSCLT, GSCLB

Filler Strip (x2)  
attach to  
outside edges

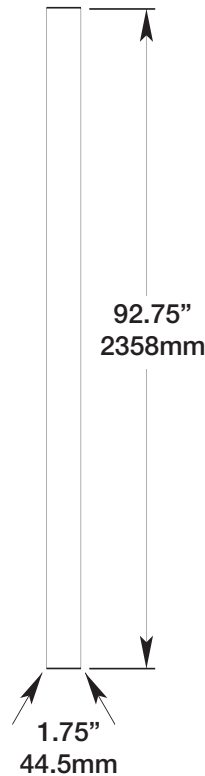

(Optional Panel)  
Instand Graphic Panel

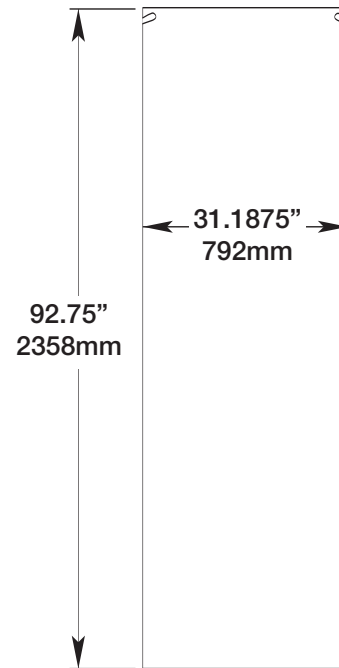

Optional Layout  
with no Filler Strips  
Use Panel 1 (x1) in center with  
Optional Panel (x2) on both sides.

Panel 2 (x2) - Laminate Panel for vinyl application  
(Templates available - Contact Solutions Studio)

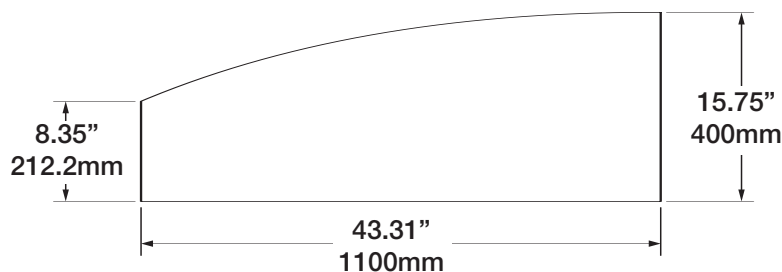

## Monet

Magnetic Panels (with stiffeners hidden)

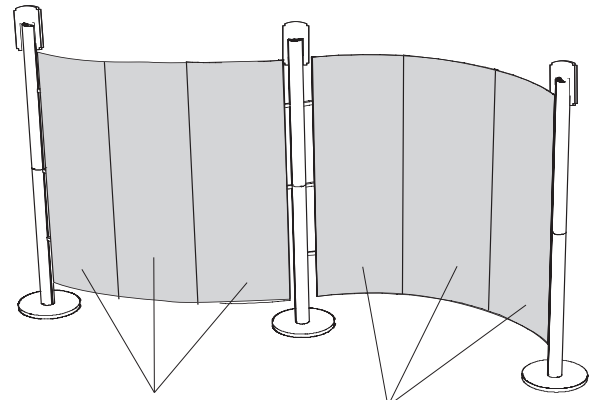

Single-Sided: Panel 1 (x3)  
Double-Sided: Panel 1 (x6)

Single-Sided: Panel 2 (x3)  
Double-Sided: Panel 2 (x6)

Panel 1 - Convex  
Magnetic Panel (x3)

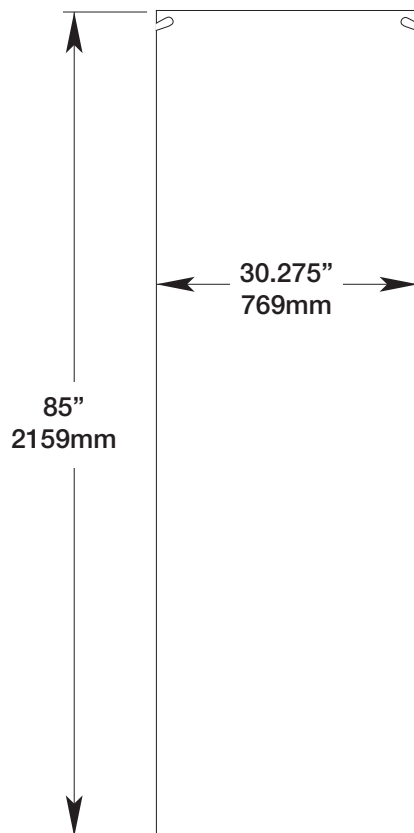

Stiffeners: GSDLBT1, GSDLTP1

Panel 2 - Concave  
Magnetic Panel (x3)

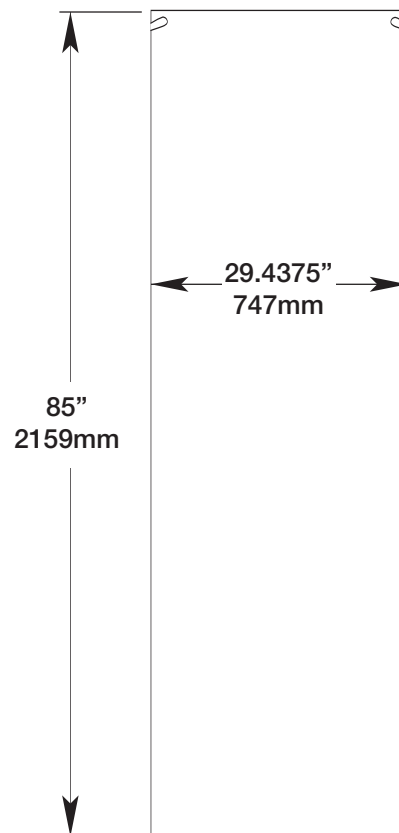

Stiffeners: GSCLT, GSCLB

\* Note: For double-sided configurations, panel measurements are the same.



# Nomadic DesignLine™

## Da Vinci

### Instand and Tension Fabric Panels

Panel 1 - FEU3SR  
Instand Classic End Cap

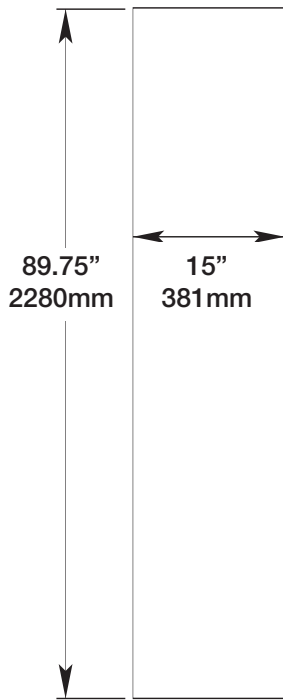

**Stiffeners: GSSRT, GSSRB**

Panel 2 - FPC3  
Instand Classic Panel (x4)

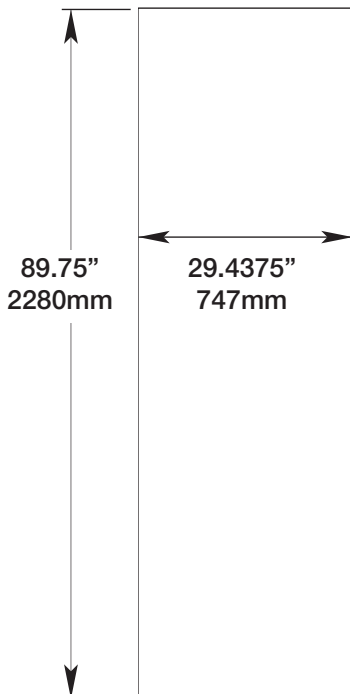

**Stiffeners: GSCLT, GSCLB**

Filler Strip  
FPP3SH  
attaches to  
inside edge

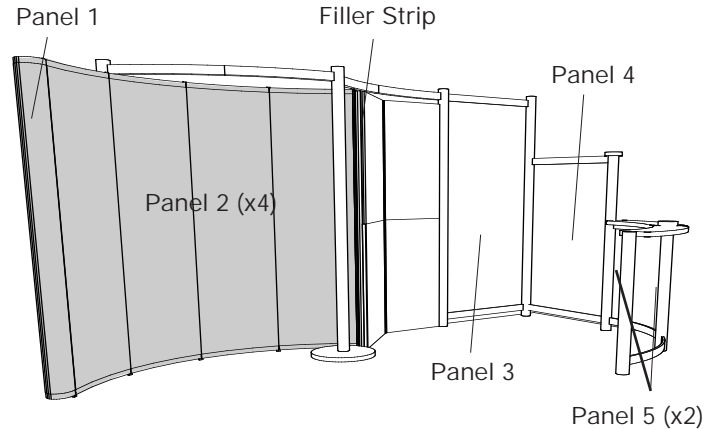
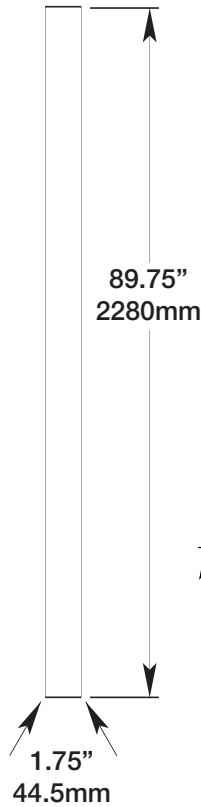

\*Image area only.  
Add 4" bleed to  
pole-pocket edges,  
and 2" bleed to  
hemmed edges.

Panel 3 - Tension Fabric\*

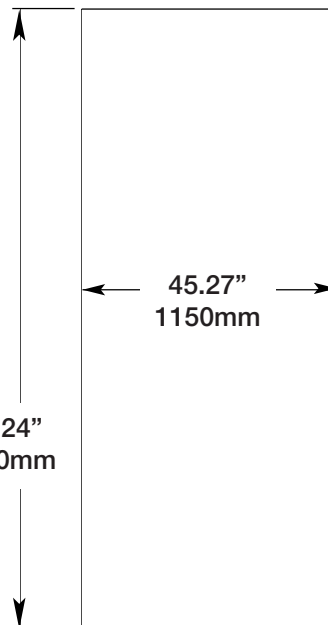

Panel 4 - Tension Fabric\*

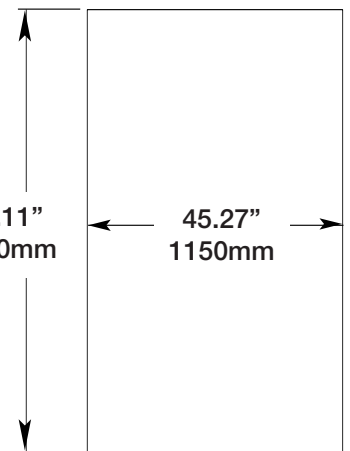

Panel 5 - Tension Fabric\* (x2)

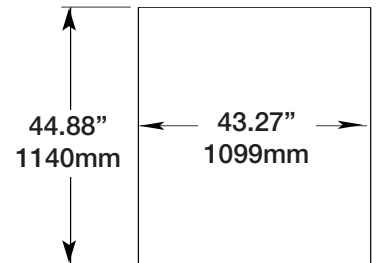

## Dali

**Magnetic Panels (with stiffeners hidden)**  
**Tension-Fabric and Sculpted Panels**

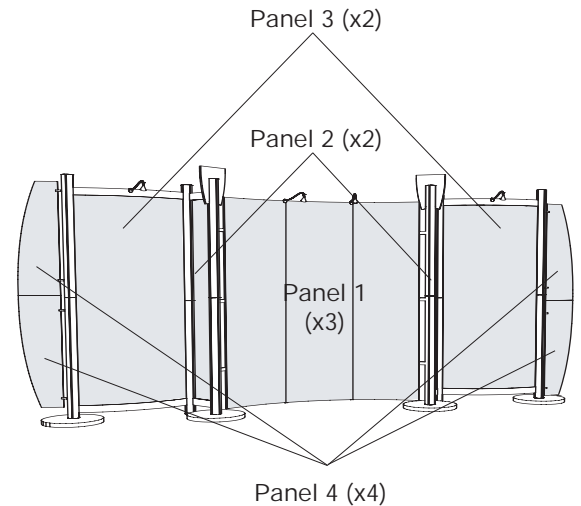

Panel 1 (x3)  
Instand Classic Panel FPC3

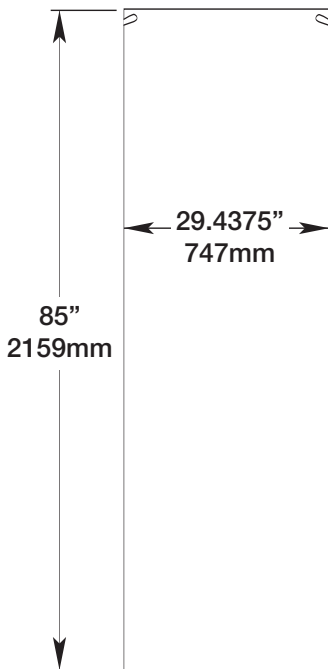

Panel 2 (x2)  
Tension Fabric\*

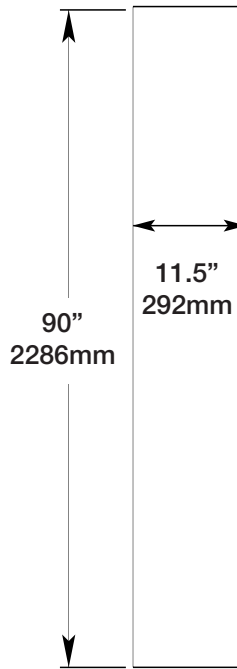

Panel 3 (x2)  
Tension Fabric\*

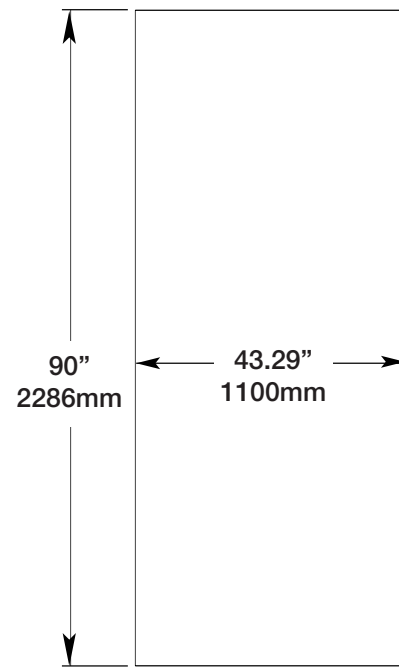

**Stiffeners: GSCLT, GSCLB**

Panel 4 (x4) - Laminate Panel for vinyl application  
(Templates available - Contact Solutions Studio)

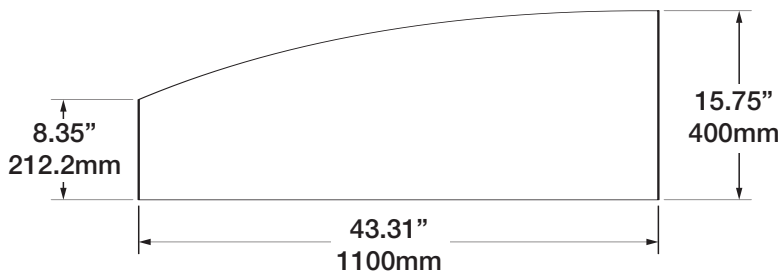

\*Image area only.  
Add 4" bleed to pole-pocket edges,  
and 2" bleed to hemmed edges.

## Raphael

Magnetic Panels (with stiffeners hidden)

Sculpted Panels

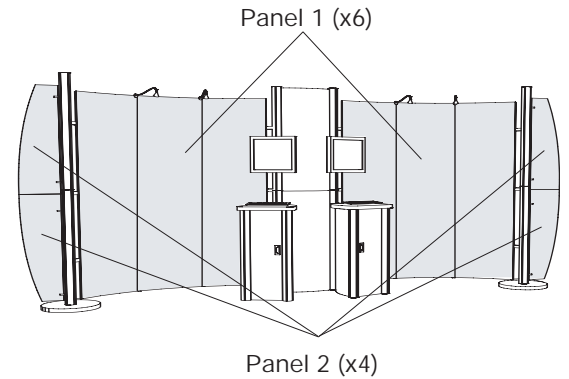

Panel 1 (x6)  
Magnetic Panels

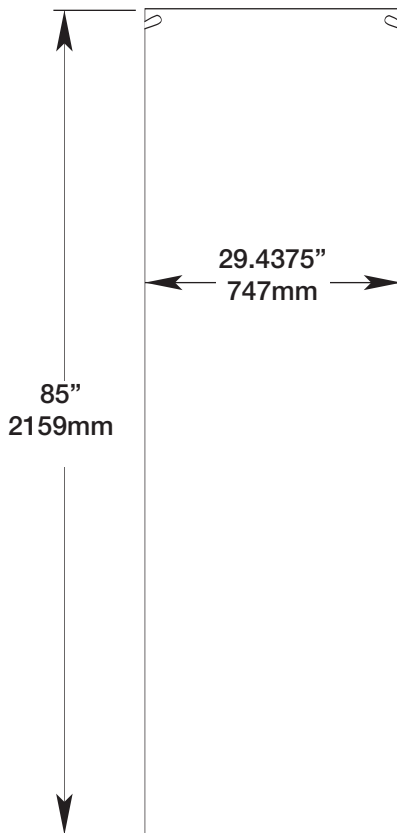

Panel 2 (x4) - Laminate Panel for vinyl application  
(Templates available - Contact Solutions Studio)

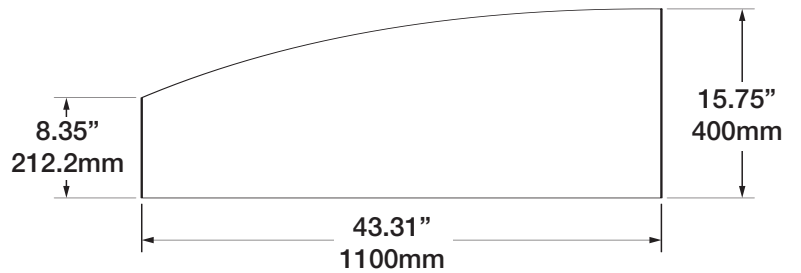

## Poussin

Instand Panels (with stiffeners hidden)

Sculpted Panels

Approx. 160 x 240 - contact  
Nomadic for specific sizing.

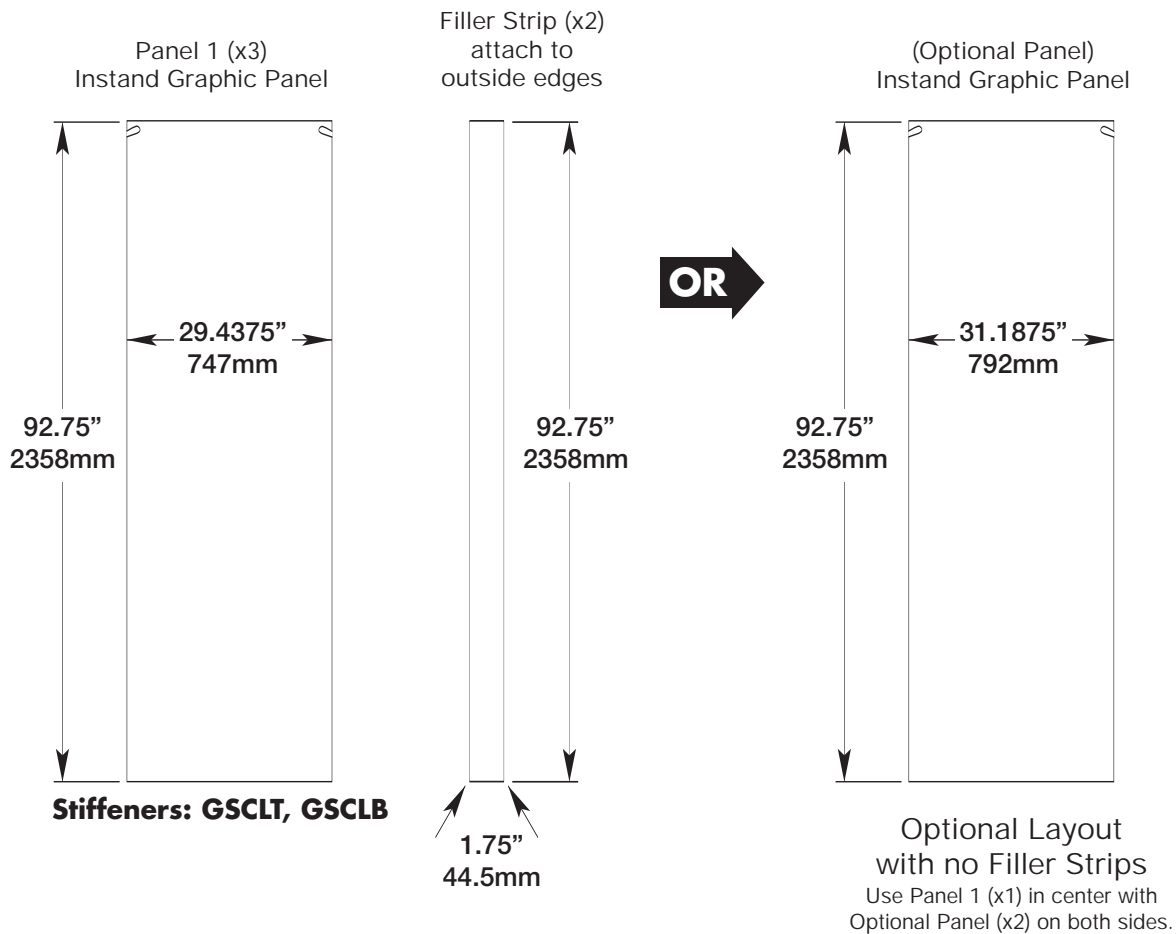
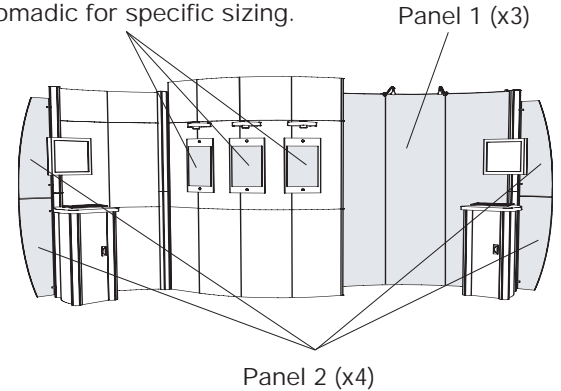

Panel 2 (x4) - Laminate Panel for vinyl application  
(Templates available - Contact Solutions Studio)

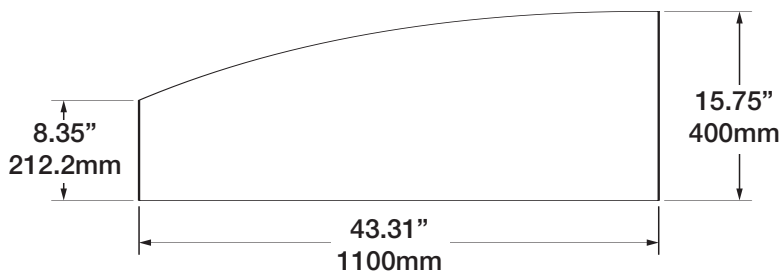

## Blake

Instand Panels (with stiffeners hidden)

Sculpted Panels

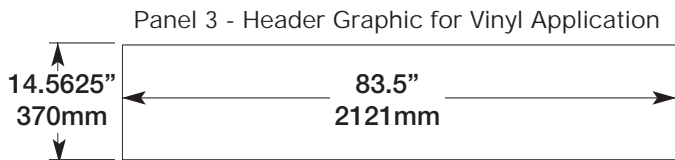
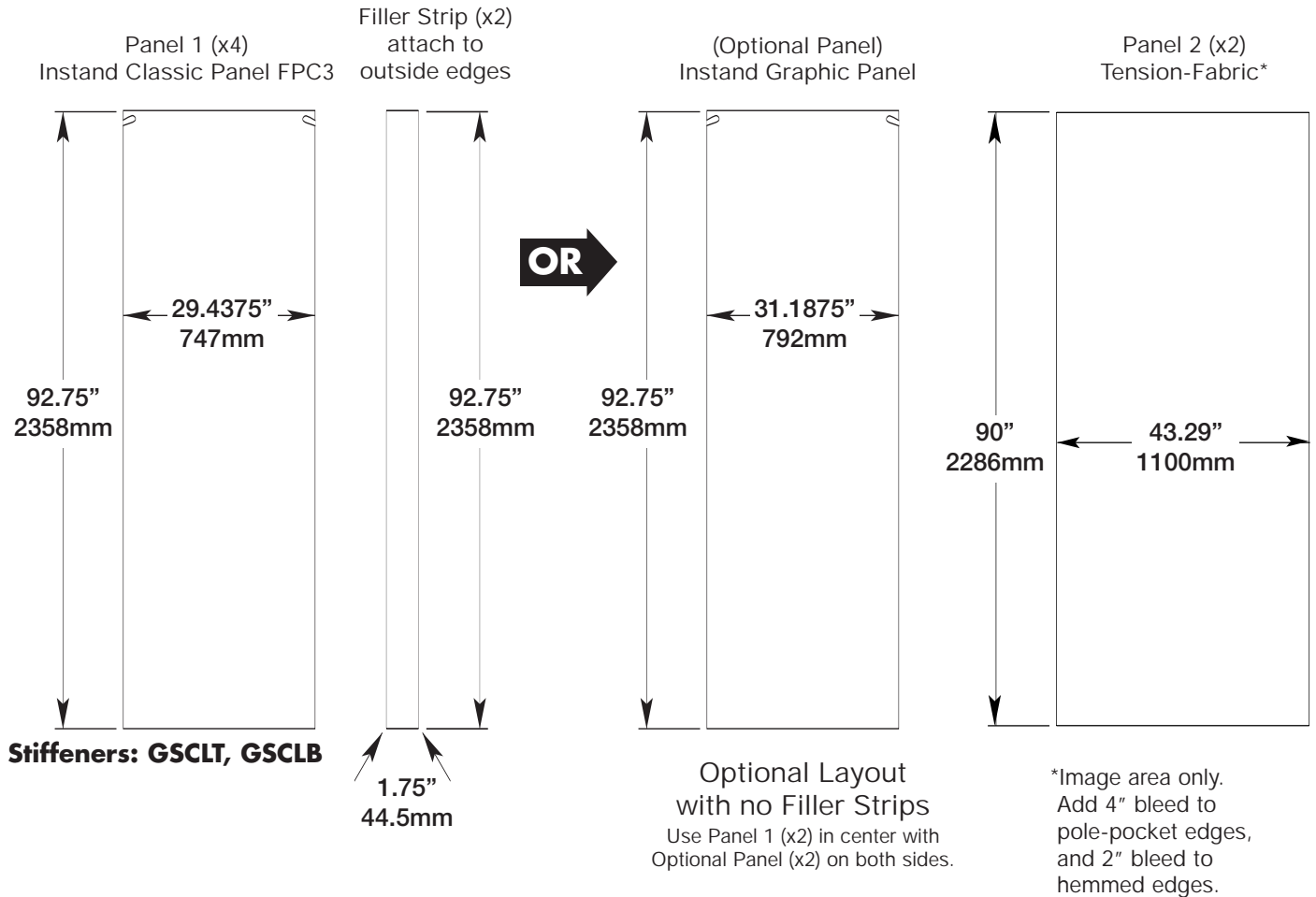
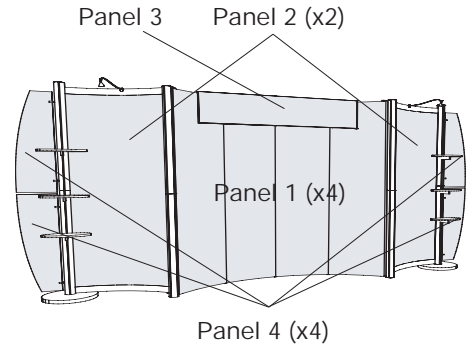

Panel 4 (x4) - Laminate Panel for vinyl application  
(Templates available - Contact Solutions Studio)

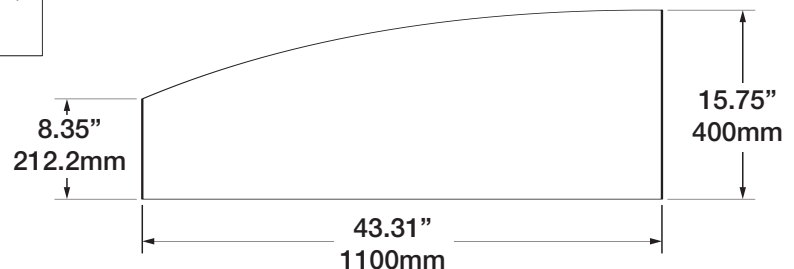

## Michelangelo

### Sculpted and Tension-Fabric Panels

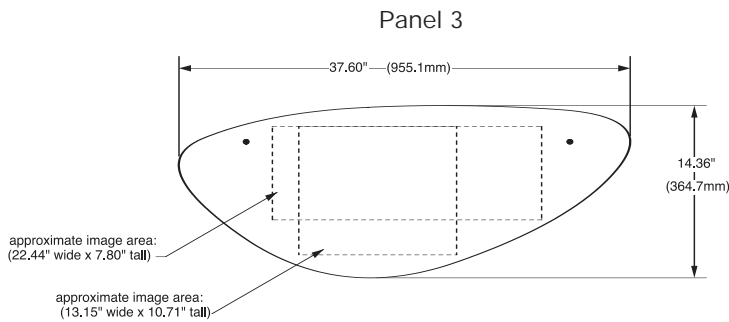
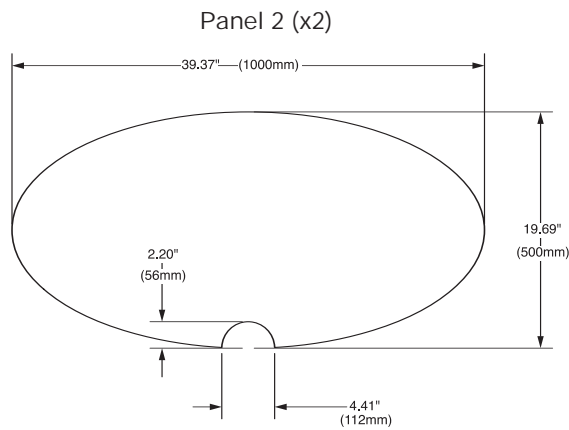
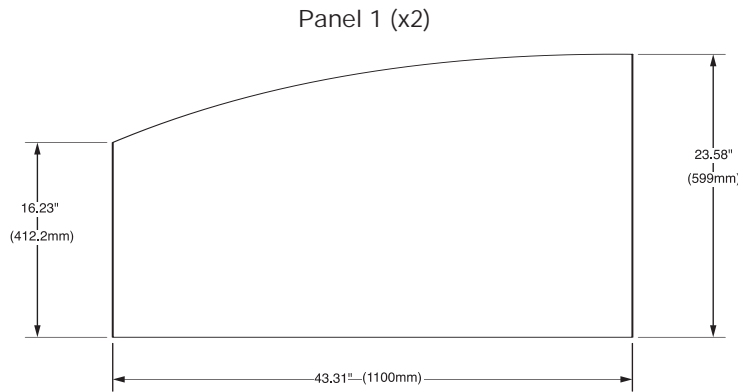

Panel 4 (x4) - Laminate Panel for vinyl application  
(Templates available - Contact Solutions Studio)

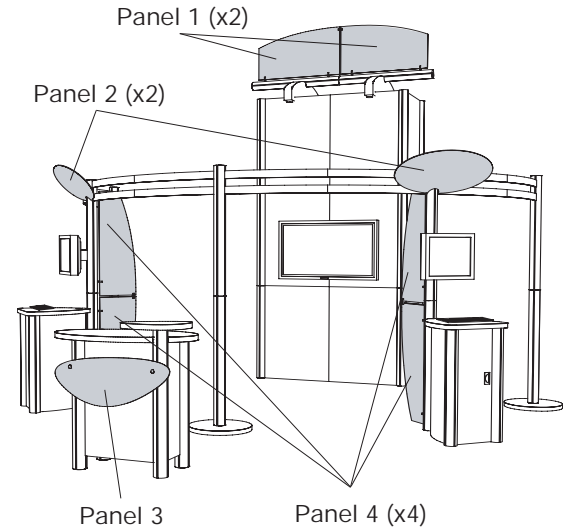
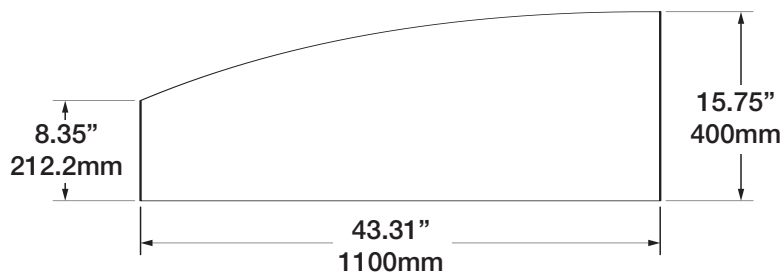

## Botticelli

### Velcro® Panels

Panel 1  
Detachable Velcro Panel

Front

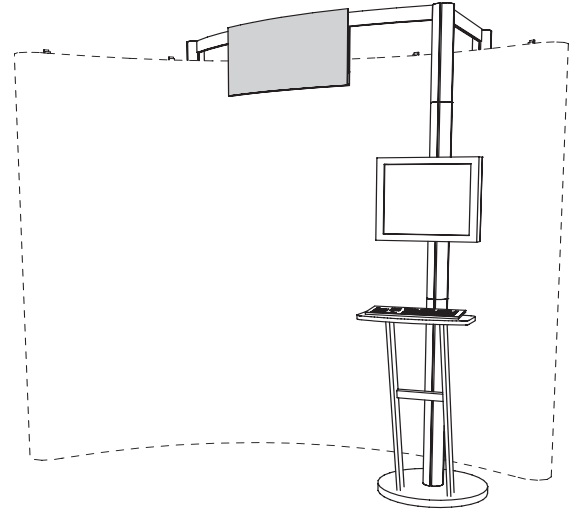
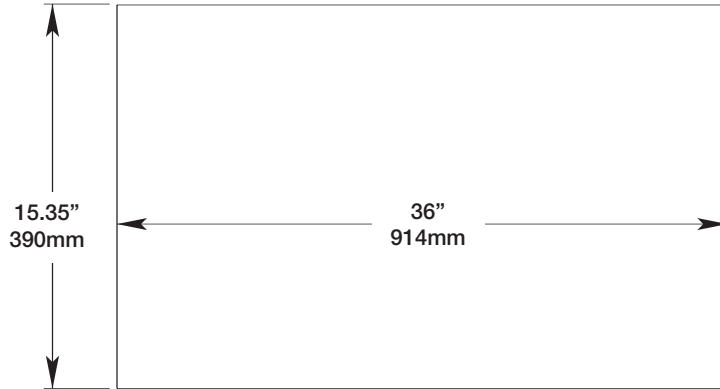

Back



Back Side  
Apply .5" hook  
velcro to rear edges

# Whistler

## Velcro® Panels

Panel 1  
Detachable Velcro Panel

Front

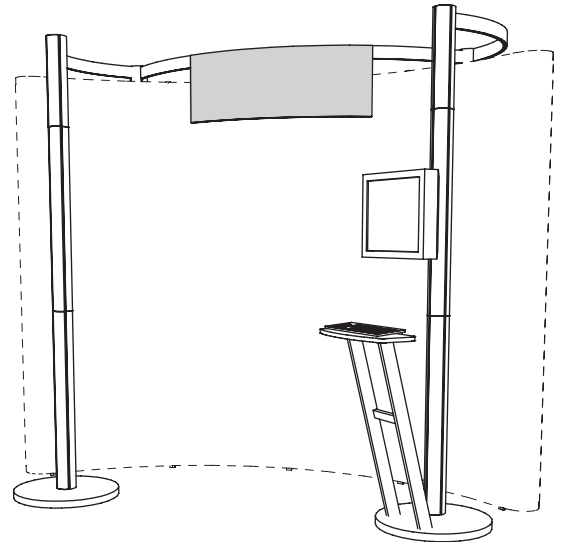
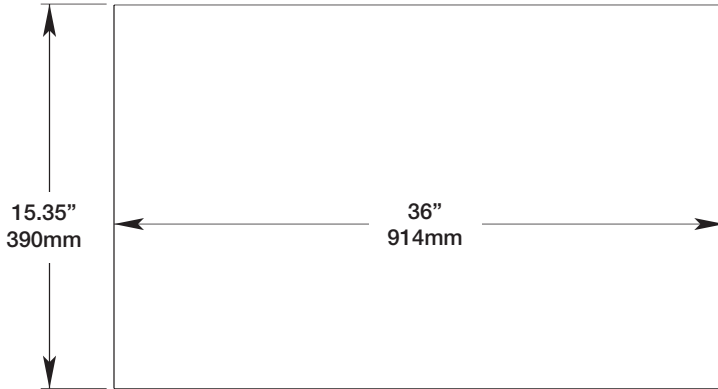

Back



Back Side  
Apply .5" hook  
velcro to rear edges



## Goya

### Tension Fabric and Sculpted Panels

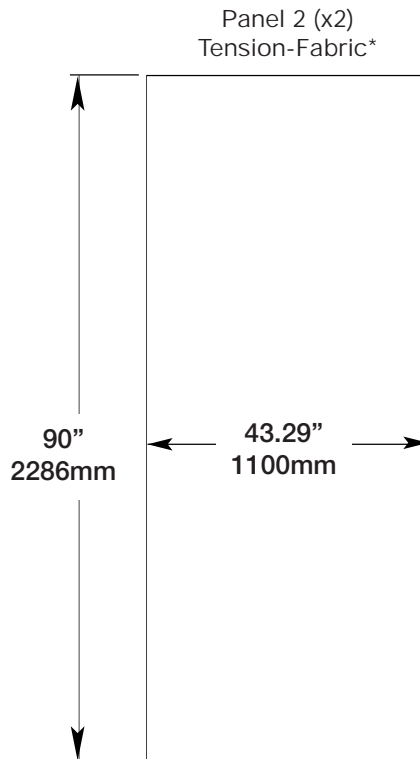
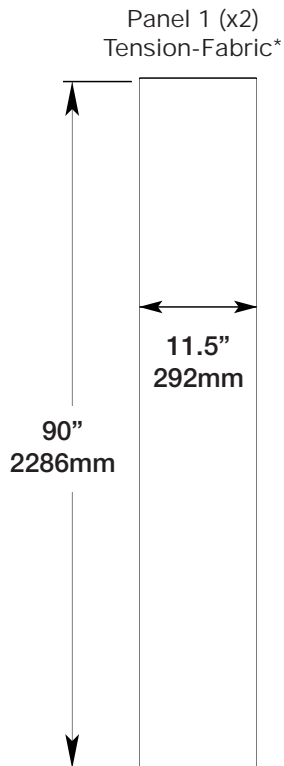
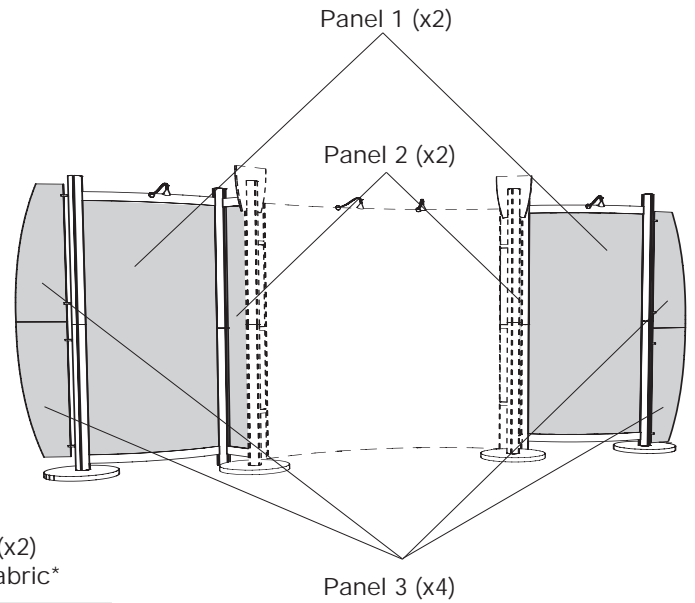

\*Image area only.  
Add 4" bleed to pole-pocket edges,  
and 2" bleed to hemmed edges.

Panel 3 (x4) - Laminate Panel for vinyl application  
(Templates available - Contact Solutions Studio)

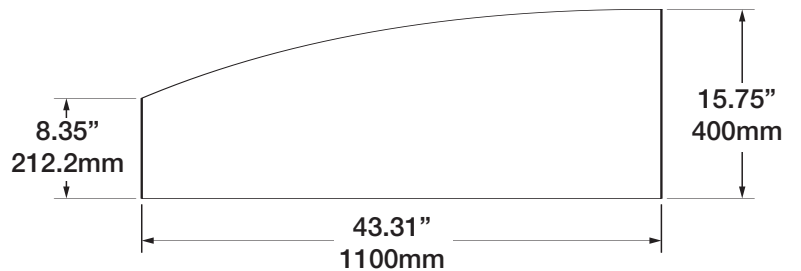

**Cassatt**  
Sculpted Panel

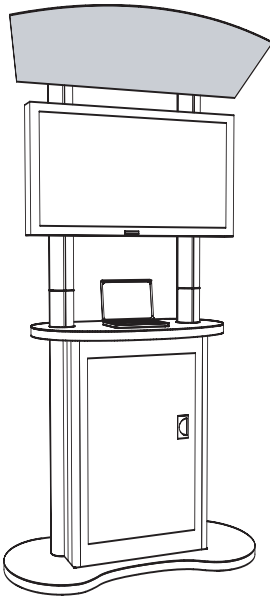

Panel 1 - Laminate panel for vinyl application  
(Templates available - Contact Solutions Studio)

## Rivera Sculpted Panels

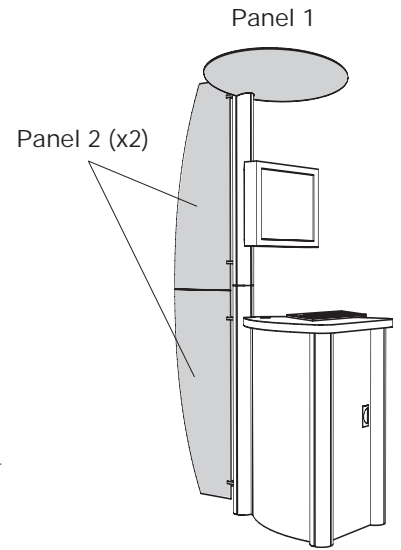

Panel 1 - Laminate panel for vinyl application

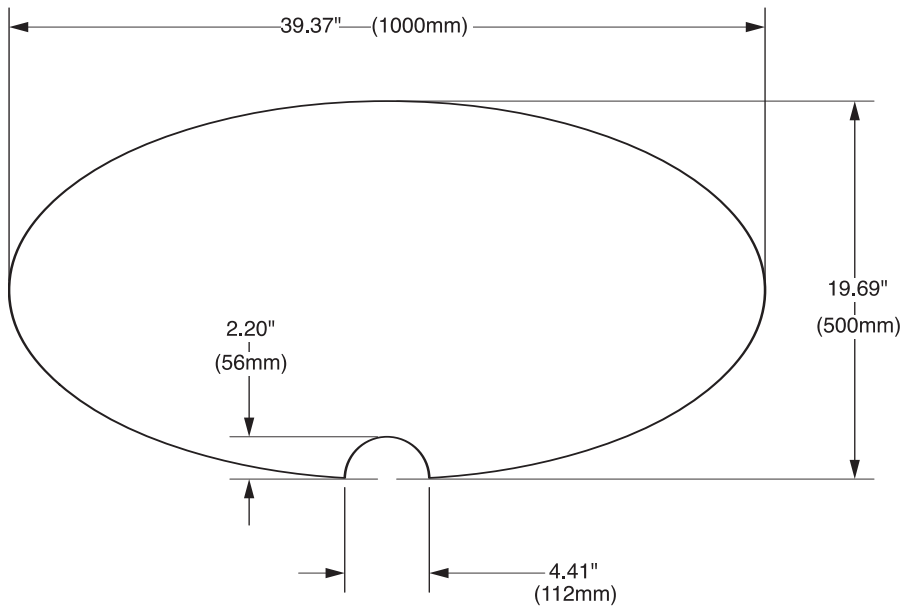

Panel 2 (x2) - Laminate Panel for vinyl application  
(Templates available - Contact Solutions Studio)

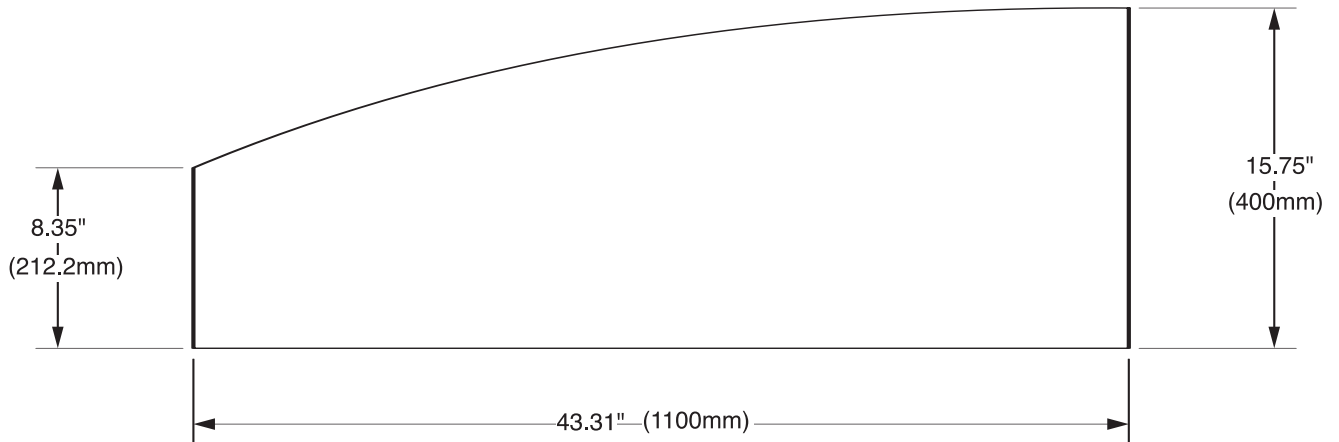

**Giovanni**  
Sculpted Panel

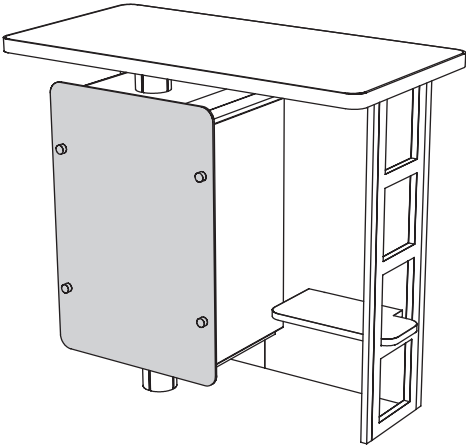

Panel 1 - Laminate panel for vinyl application  
(Templates available - Contact Solutions Studio)

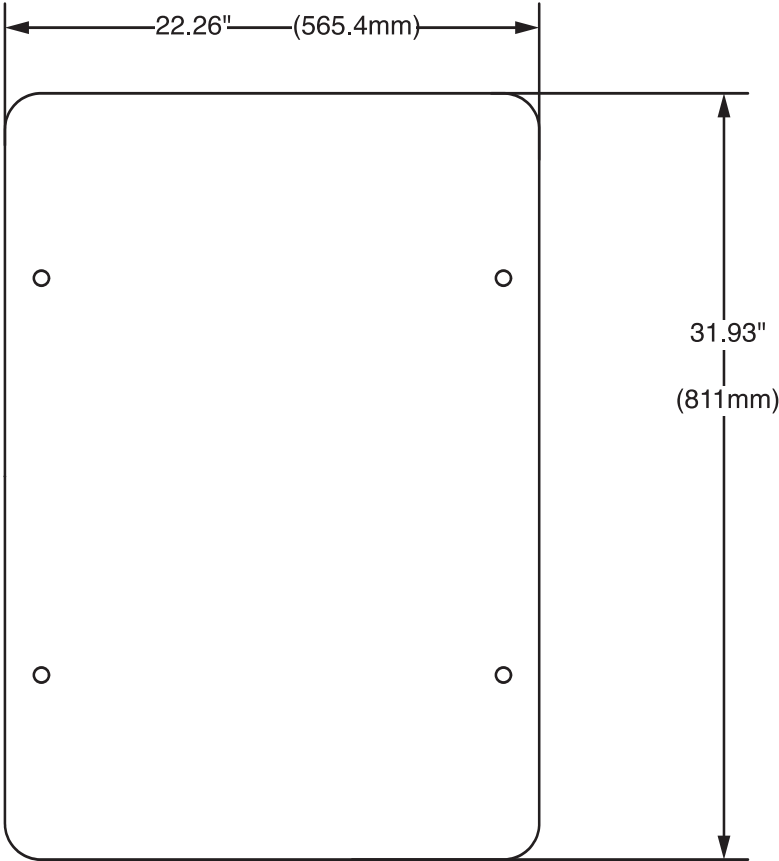

## Watteau Sculpted Panel

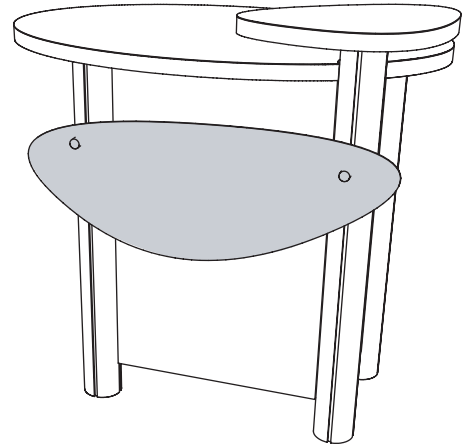

Panel 1 - Laminate panel for vinyl application  
(Templates available - Contact Solutions Studio)

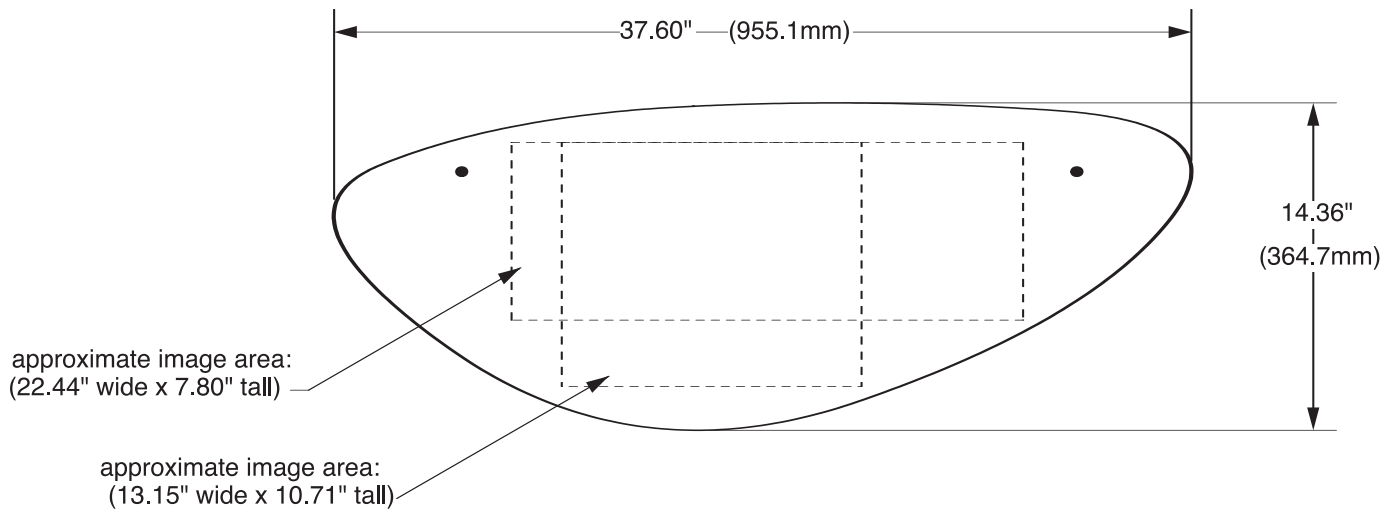

## Serov Sculpted Panel

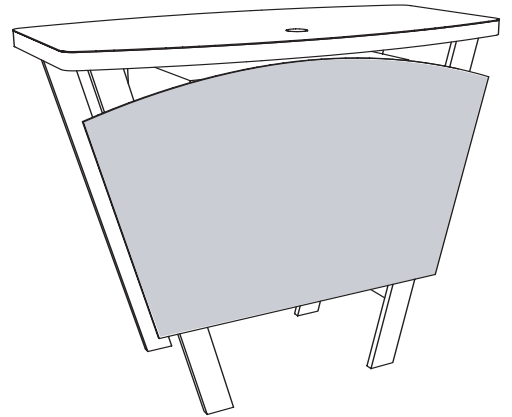

Panel 1 - Laminate panel for vinyl application  
(Templates available - Contact Solutions Studio)

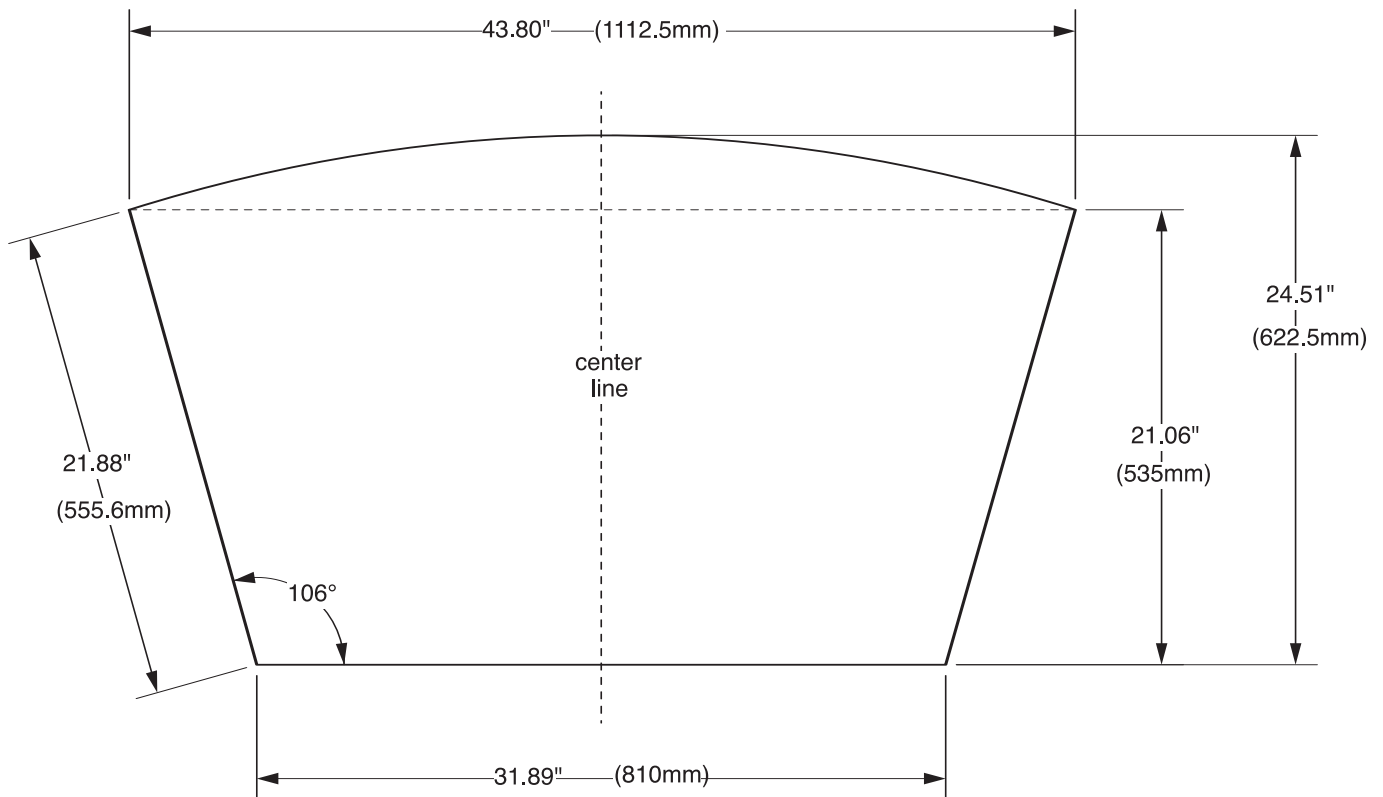

**O'Keeffe**  
Sculpted Panel

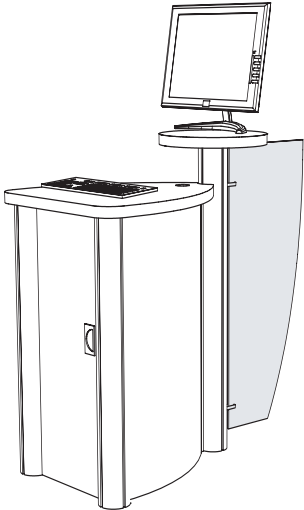

Panel 1 - Laminate Panel for vinyl application  
(Templates available - Contact Solutions Studio)

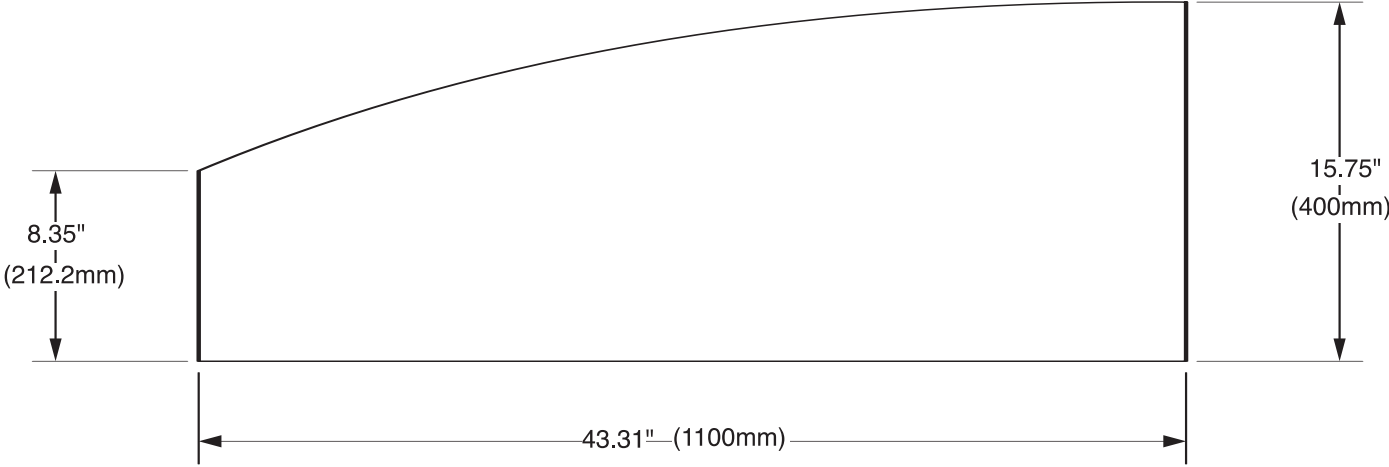

**Rodin**  
Counter Wrap Panel

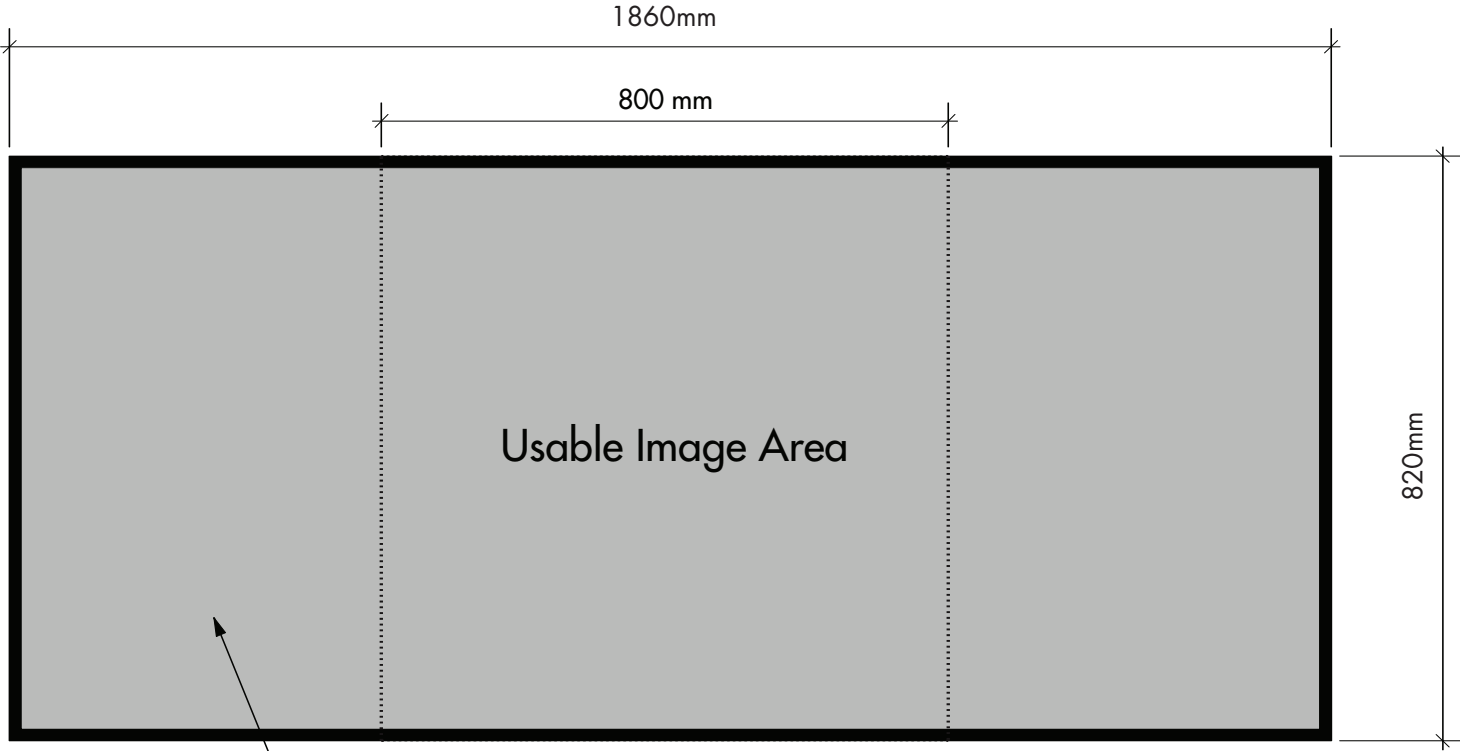
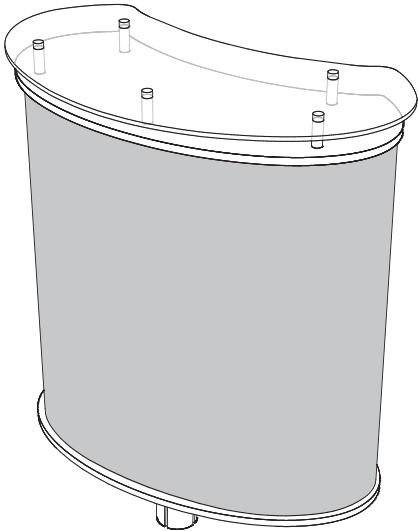

Panel Trim Size is 820mm x 1860mm with 13mm loop velcro on all four sides





## SignLine®

Fabric graphics for banner stands should have the 2" bleed. Finishing of these graphics will be with a hot knife.

| <u>Banner Stand</u> | <u>Graphic Image Area Sizes</u> |
|---------------------|---------------------------------|
| SignLine Express    | 33.5" x 87"                     |
| SignLine Swift      | 33.5" x 87"                     |
| SignLine Standard   | 68" x 33.5"                     |
|                     | 68" x 36.75"                    |
|                     | 68" x 41.5"                     |
|                     | 92" x 33.5"                     |
|                     | 92" x 36.75"                    |
|                     | 92" x 41.5"                     |
| SignLine Lite       | 84" x 31"                       |

\* Note: Sizing assumes dye sub printed graphic is on poly knit material.

## SignLine Express Graphic Attachment Instructions

**Step One:** Attach top rear of graphic panel to double sided tape on graphic hanger bar.  
(Diag. A)

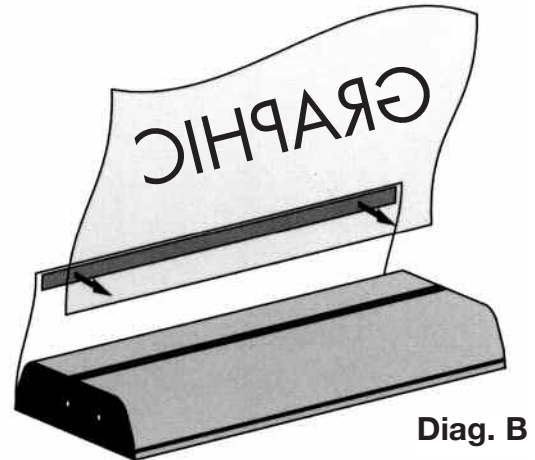
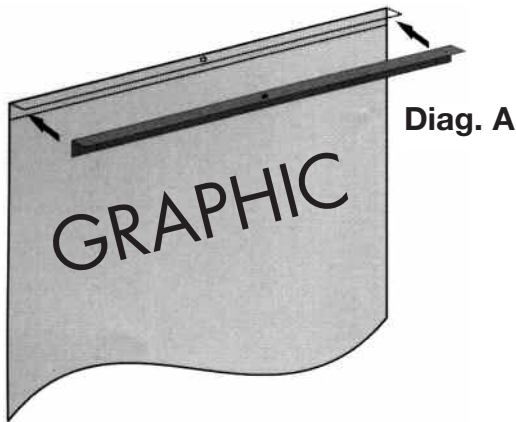

**Step Two:** Attach front bottom edge of graphic panel to double sided tape on leader sheet, as shown. **Graphic must be parallel to the header.** (Diags. B&C)

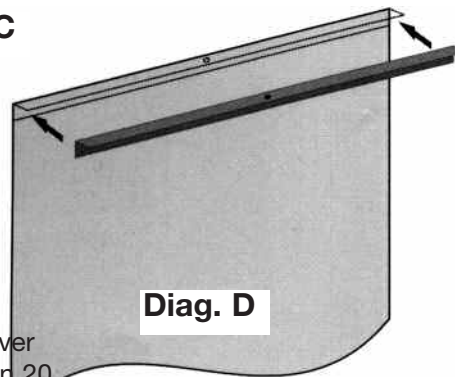
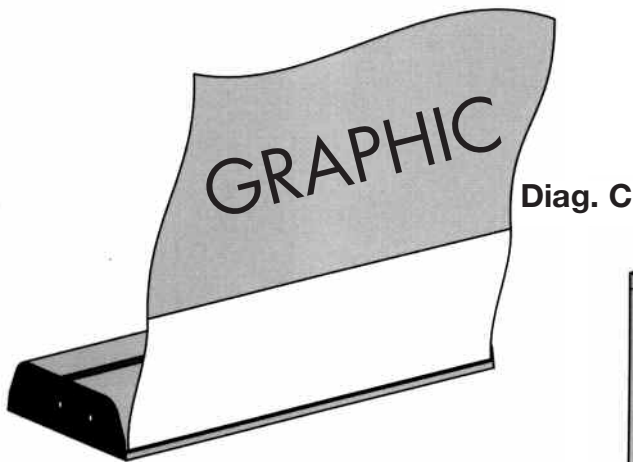

**Step Three:** Use a standard flat headed screwdriver to wind graphic into unit. We recommend between 20 and 24 complete clockwise turns to achieve optimum tension, although this may vary (+ / -) with different styles of graphic materials.  
(Diag. D)

To untension graphic panel, place screwdriver into slot and push to disengage ratchet. Hold in and turn counter-clockwise until tension in spring is released. To remove graphic panel carefully peel it off leader sheet. The graphic hanger may be removed or replaced.

## SignLine Swift

### Graphic Attachment Instructions

**Step One:** Apply the top rear of the graphic panel to the hanger bar.  
 (Diag. A)

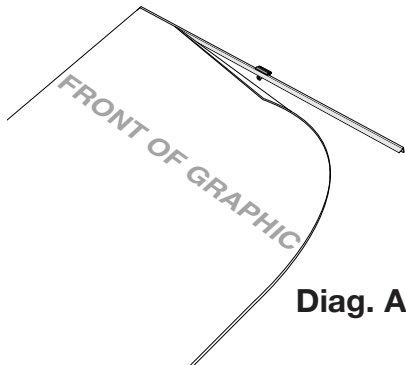

**Step Two:** Apply the bottom of the graphic panel to the leader strip.  
**Graphic must be parallel to the header.** (Diag. B)

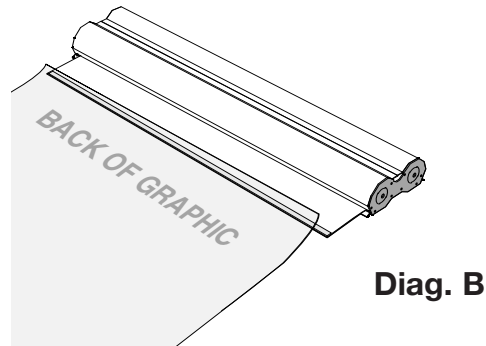

**Step Three:** Using a large flat head screwdriver, turn the screw head in a clockwise direction until the graphic panel retracts into the bannerstand.  
 (Diag. C)

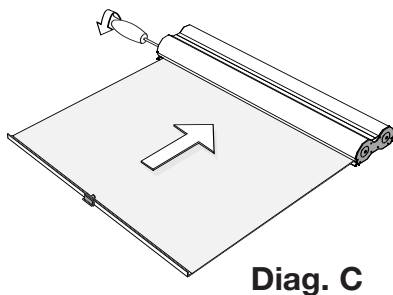

**Step Four:** If problems occur with the graphic panel leaning to one side, let the graphic panel down. Slowly turn the screw head 3-4 times in an anti-clockwise direction to release the excessive tension on the graphic panel.  
 (Diag. D)

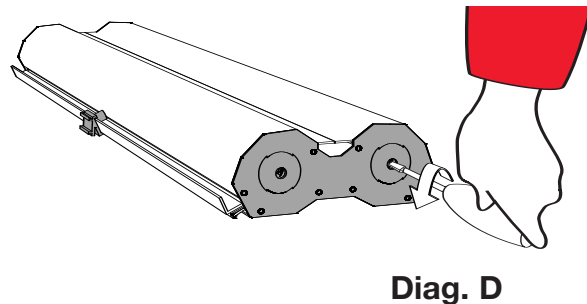

**Step Five:** To change the graphic panel the tension needs to be released. To release the tension push in the screw head firmly while the graphic panel is set up. Use a narrow cylindrical object e.g a pen.  
 (Diag. E)

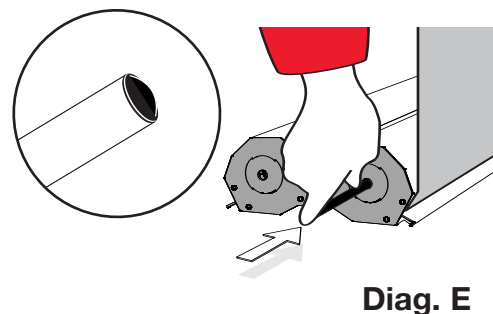

Top

Image Height:  
7'

Image Height:  
5'

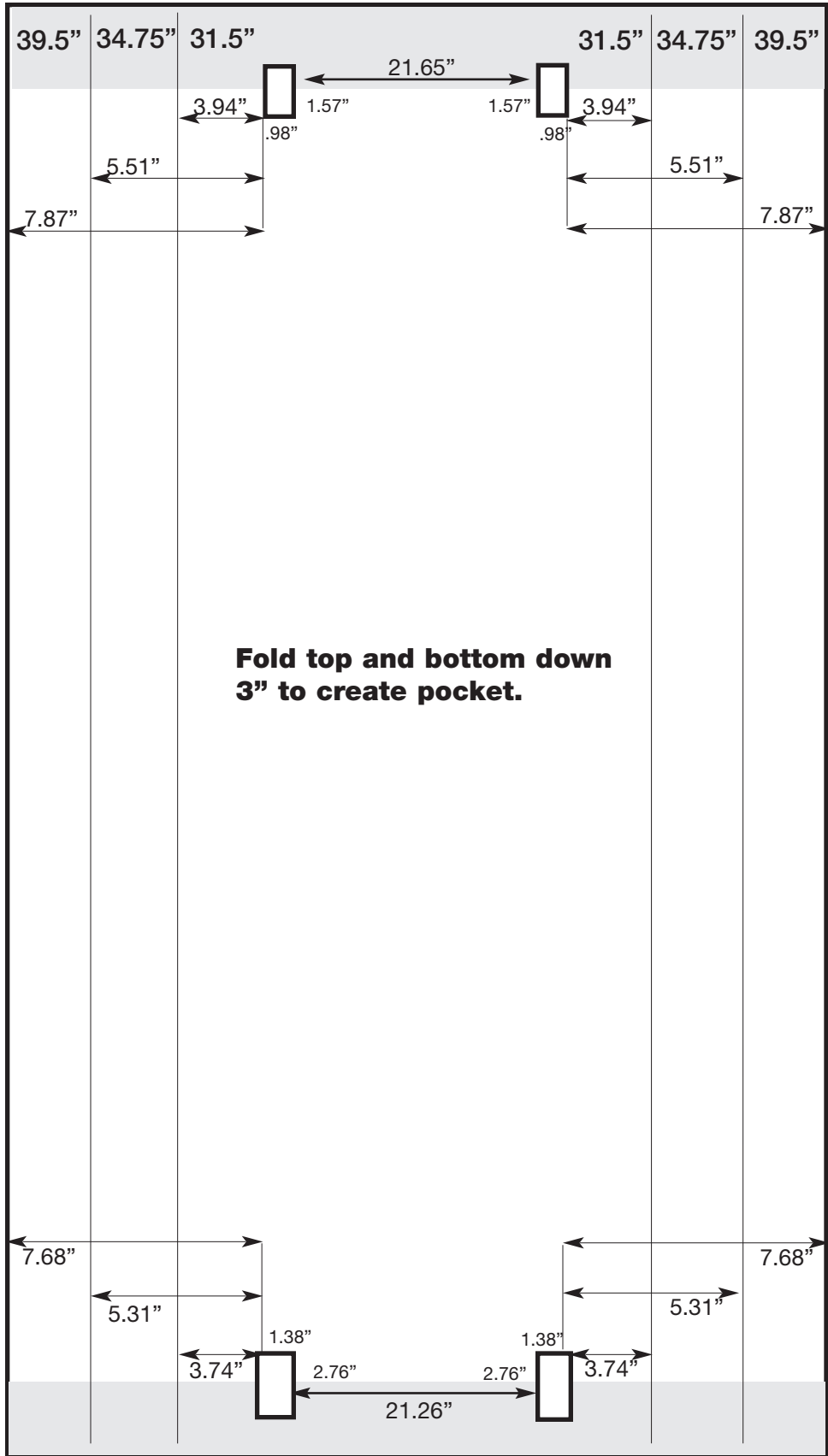

3"

Trim Size:  
7'6"

Trim Size:  
5'6"

3"

\* Note: Trim white rods with hacksaw to match selected graphic width.  
Add 3" to top and bottom of image area for pocket.

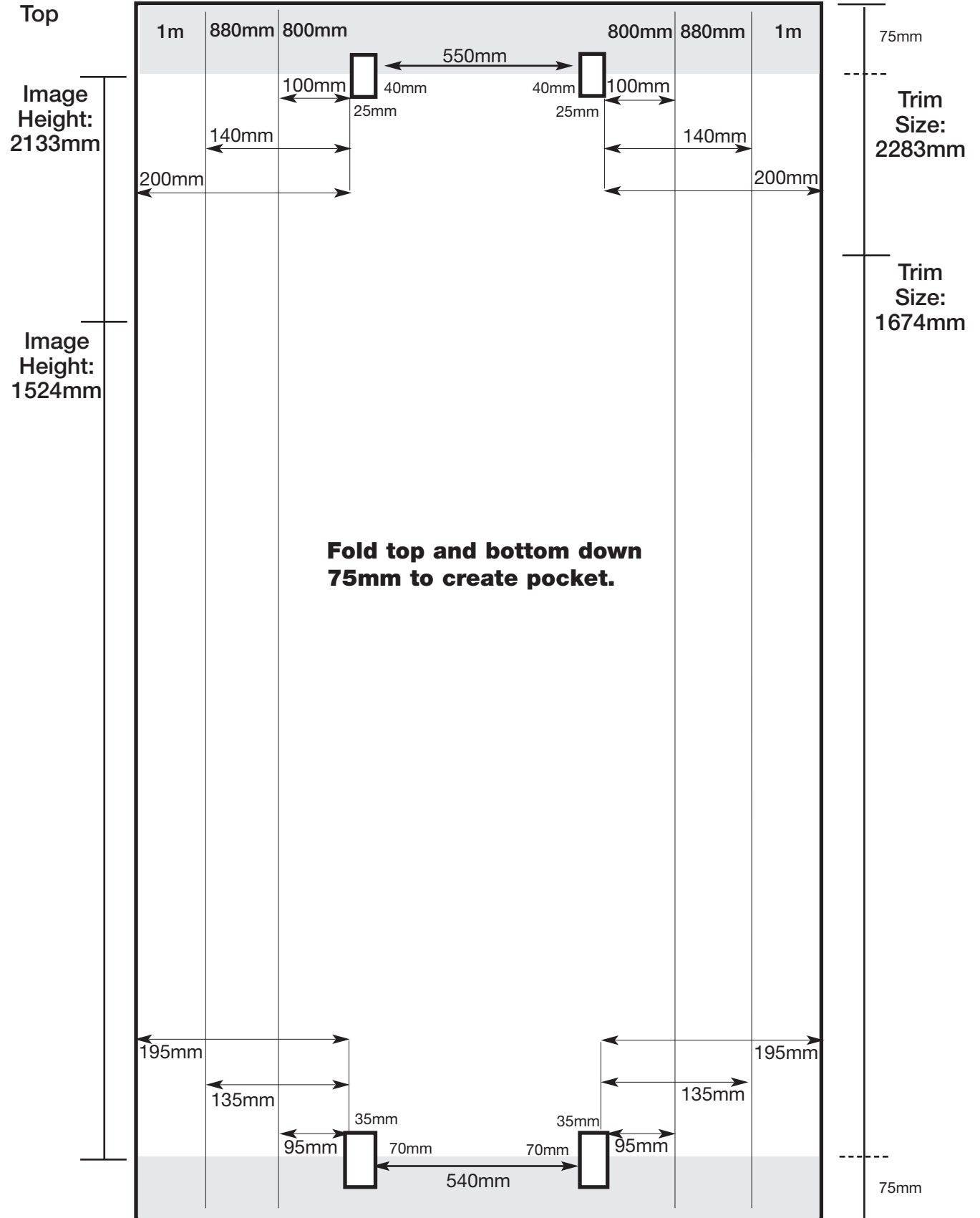

\* Note: Trim white rods with hacksaw to match selected graphic width.  
Add 75mm to top and bottom of image area for pocket.

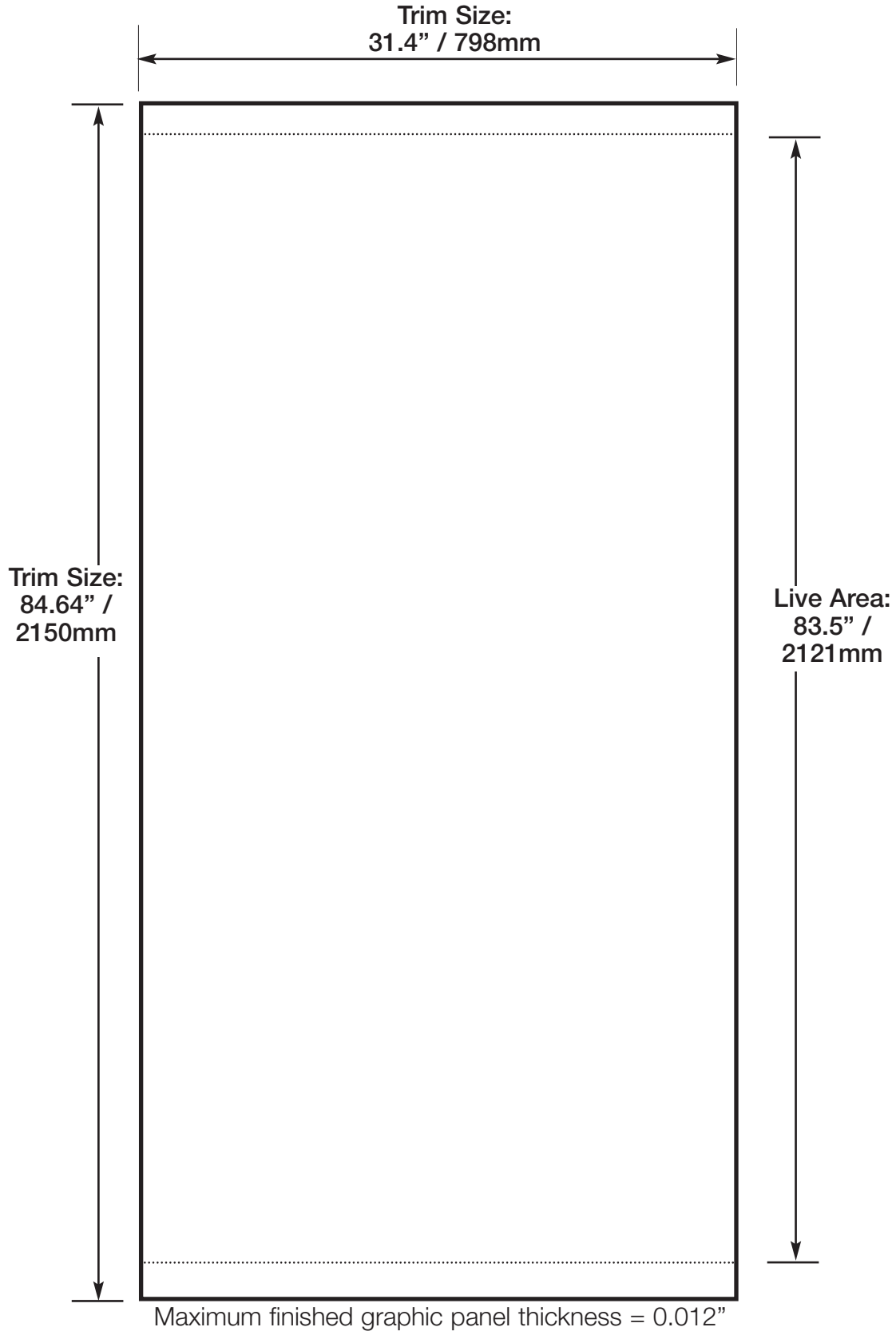

\* **Note: Dimensions shown not to scale.**

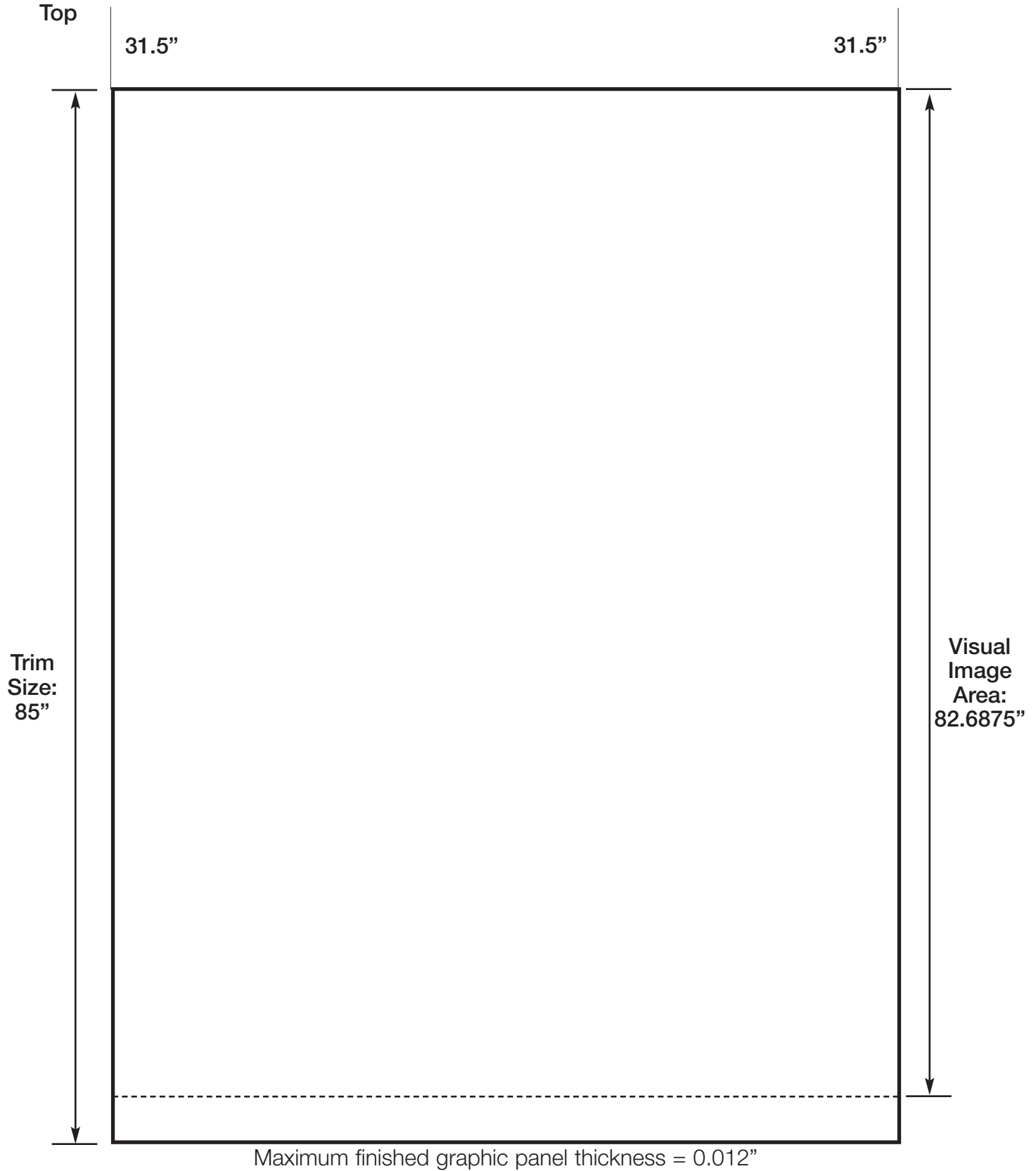

\* **Note:** Make the image flush to the top.  
The extra space is for the bottom to attach to the feeder sheet.  
Dimensions shown not to scale.

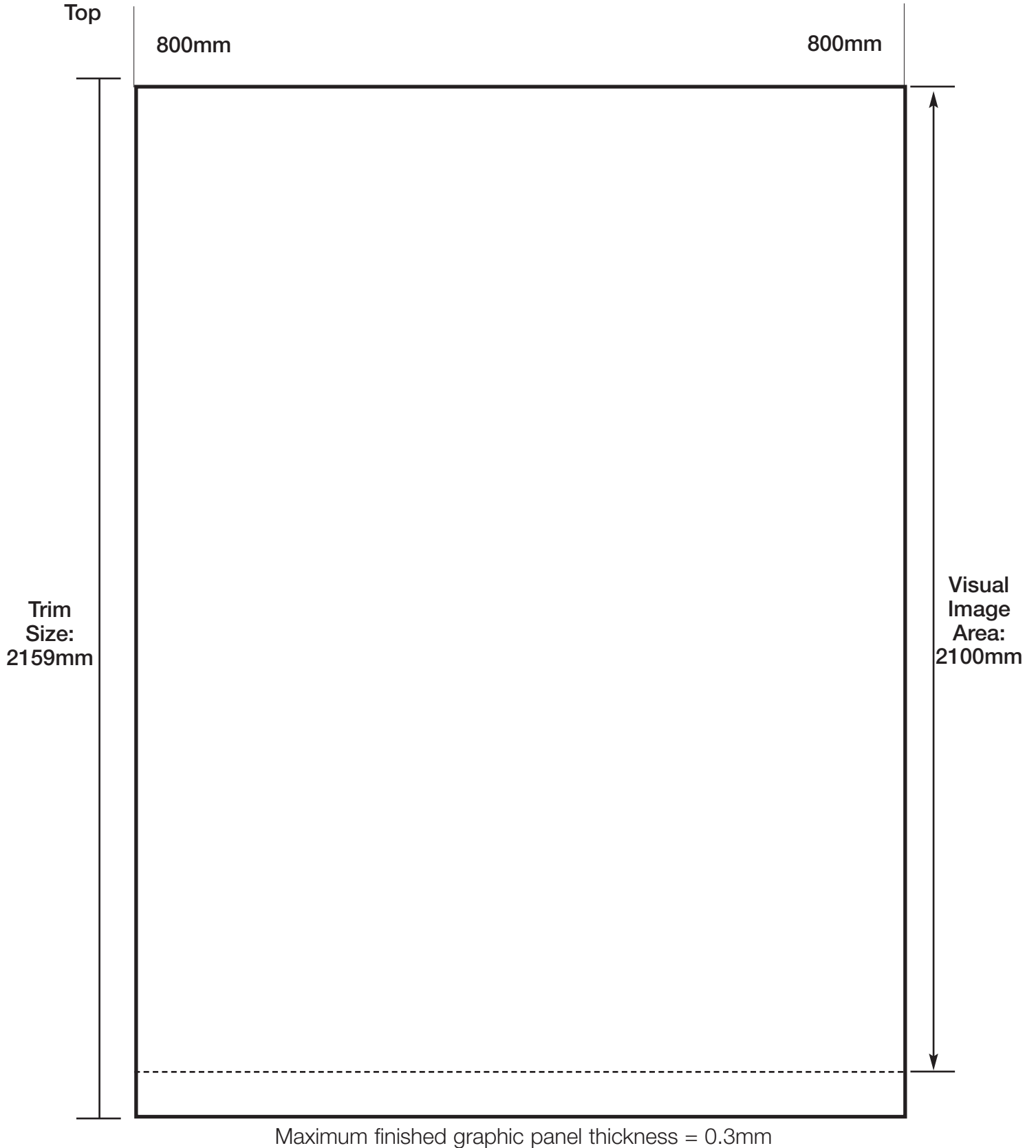

**\* Note: Make the image flush to the top.**  
The extra space is for the bottom to attach to the feeder sheet.  
Dimensions shown not to scale.

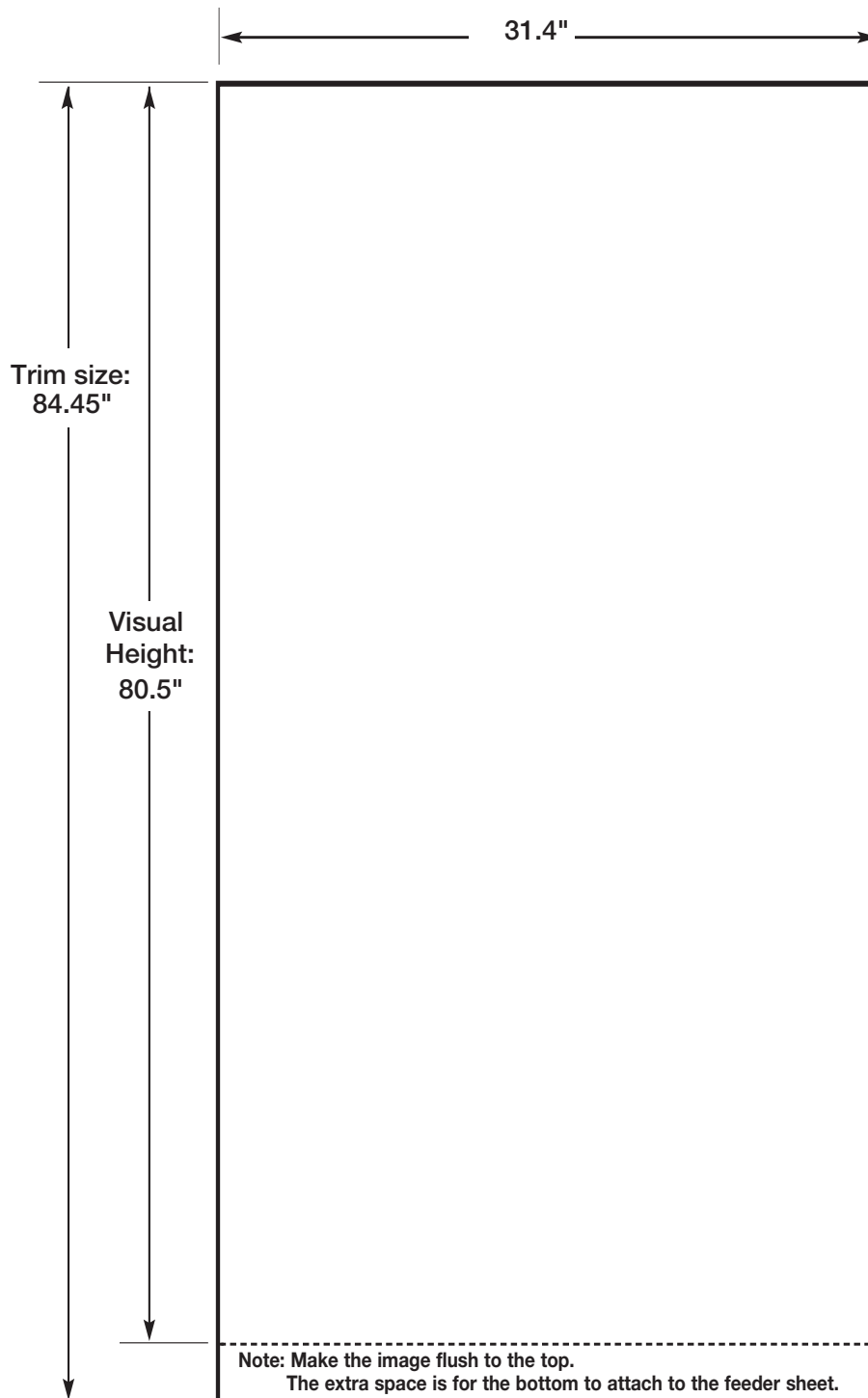

**Digital prints on film****Guidelines for Graphic Panel Thickness**

1. The graphic print must be pliable and suitable for roller bannerstands.  
We recommend an opaque film which must have a maximum thickness of 0.3mm.
2. A PVC laminating film should be used for protecting the graphic and should be used on the front side only. We recommend a maximum thickness of 0.15mm.

## Digital prints on film

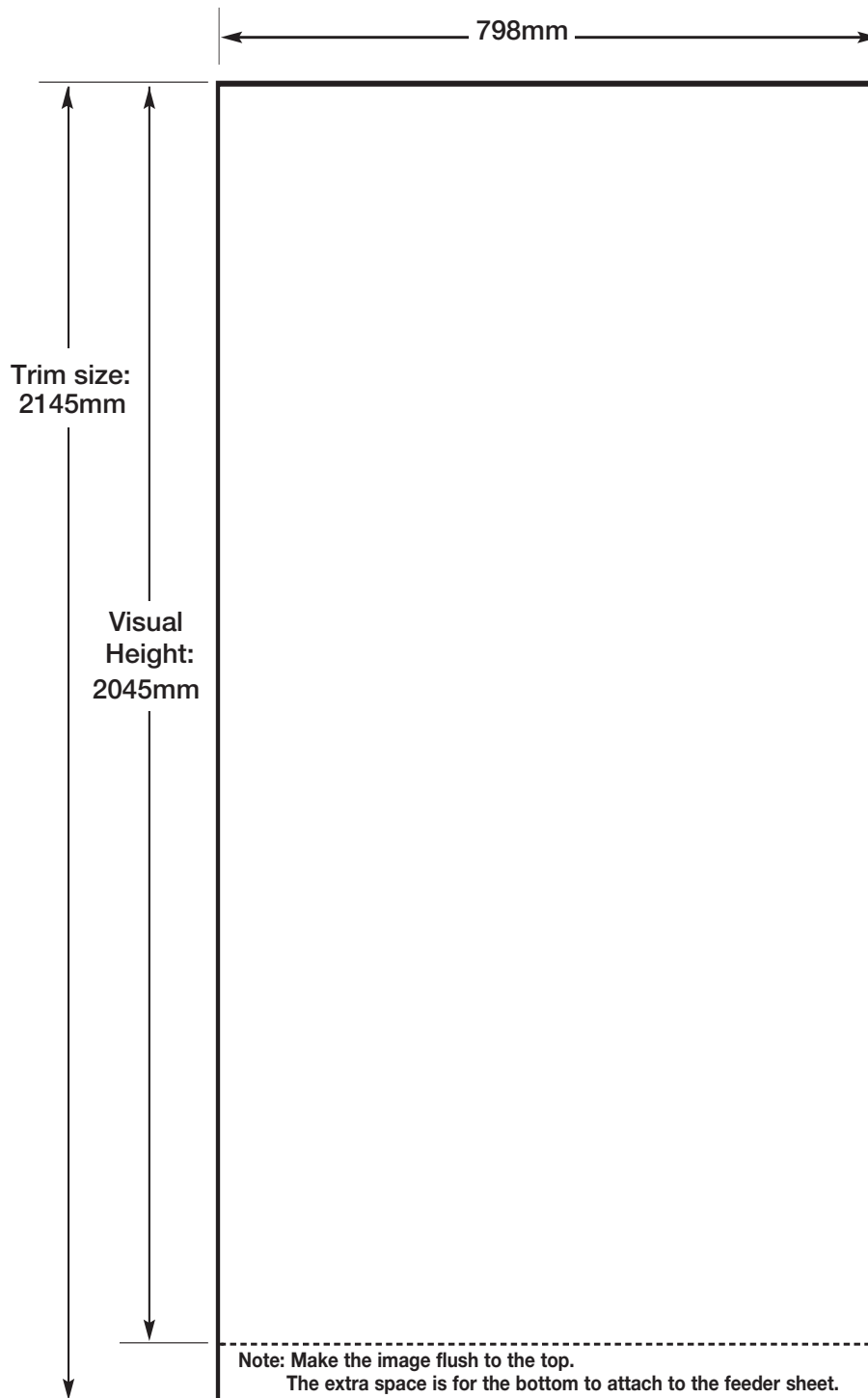

### Guidelines for Graphic Panel Thickness

1. The graphic print must be pliable and suitable for roller bannerstands.  
We recommend an opaque film which must have a maximum thickness of 0.3mm.
2. A PVC laminating film should be used for protecting the graphic and should be used on the front side only. We recommend a maximum thickness of 0.15mm.

## Headers

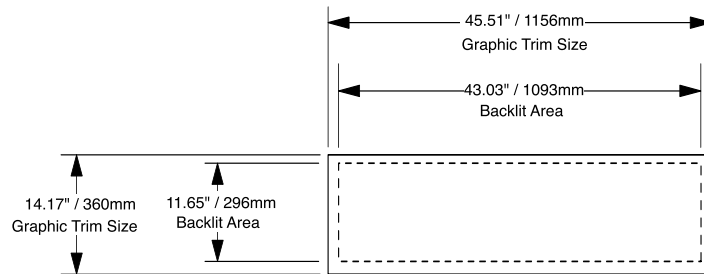
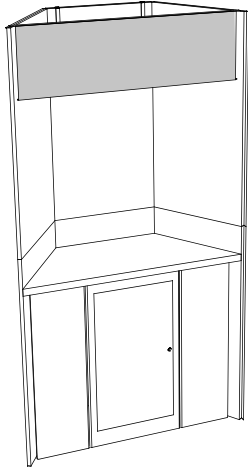

Flat Backlit Header for Single Alcove

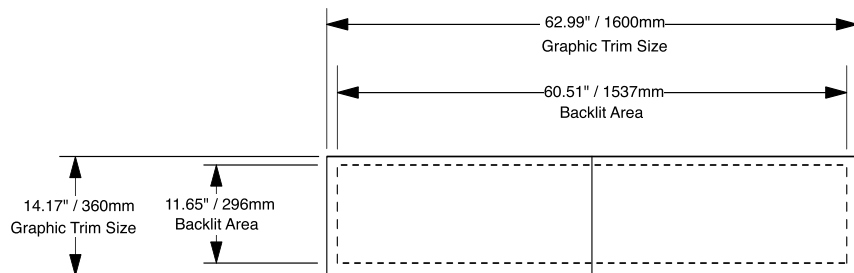
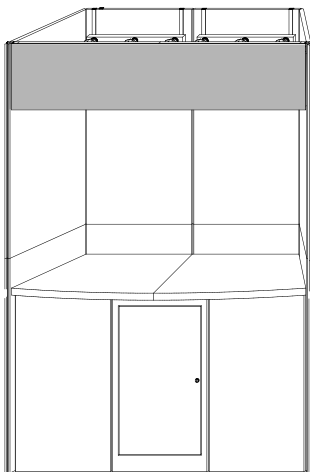

Flat Backlit Header for Double Alcove

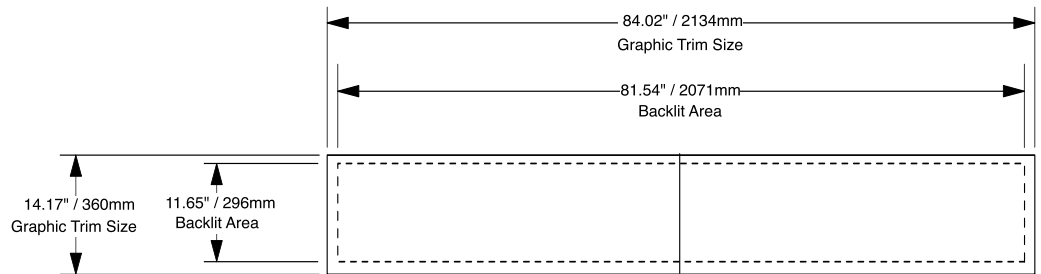
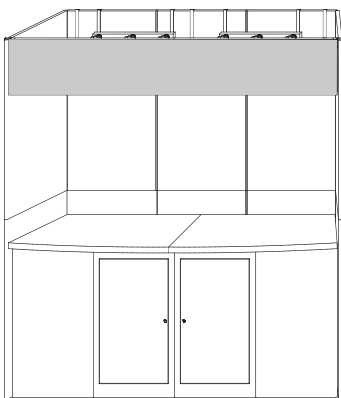

Flat Backlit Header for Triple Alcove

## Star Kit with Header

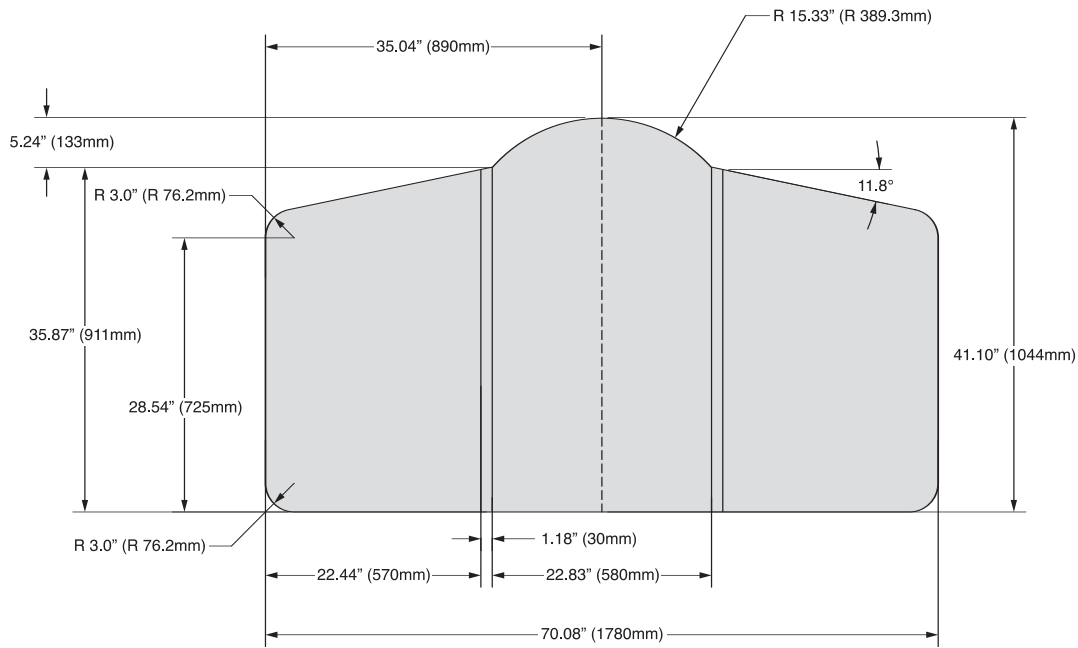

**Star Kit with Arch Header**

**Star Kit with Peak Header**

## Celebrity Kit with Header

**Celebrity Kit with Arch Header**

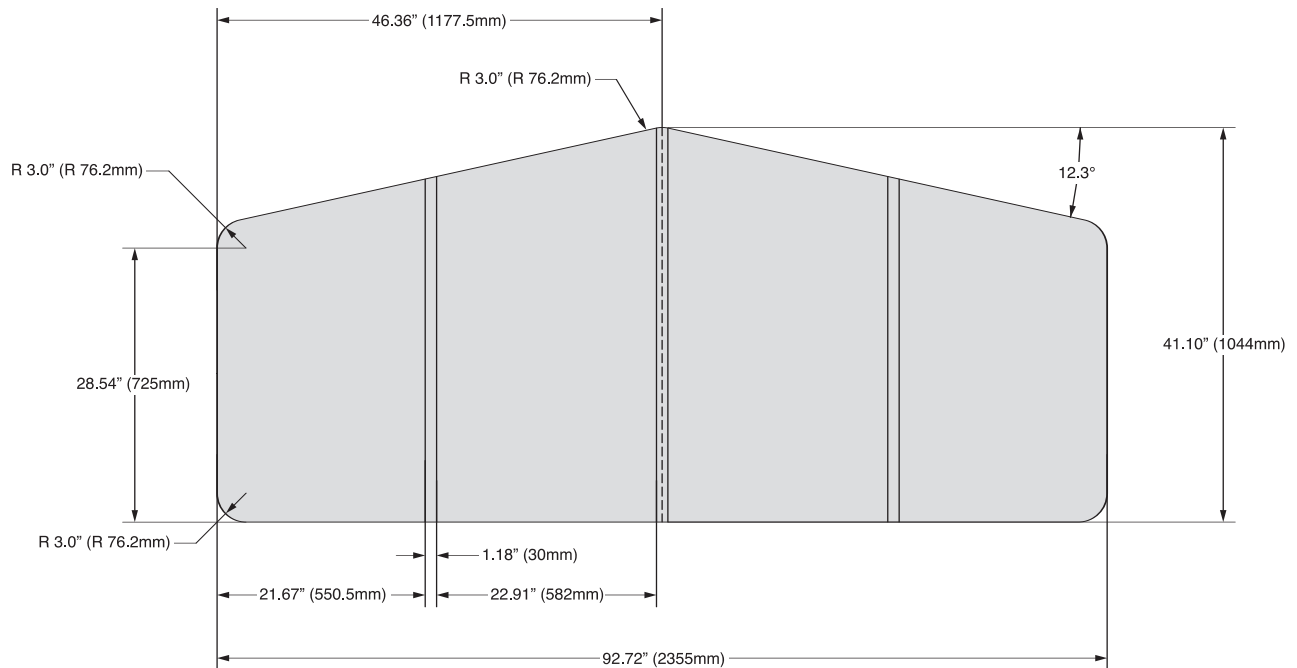

**Celebrity Kit with Peak Header**

# RollOne Case

## Graphic Wrap

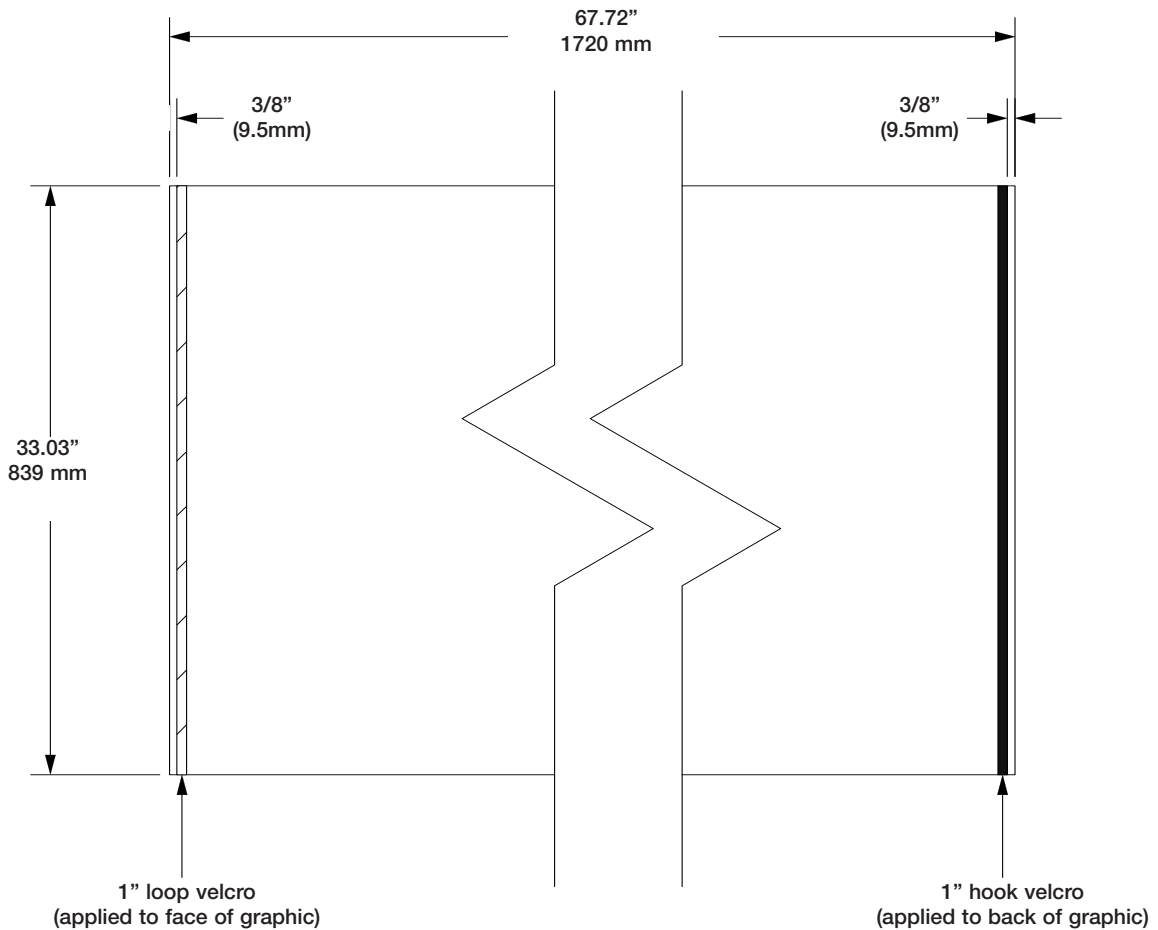
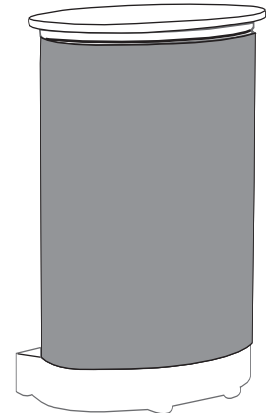

Note: When positioned on RollOne case, graphic will overlap horizontally by 1 1/8" (28.6mm)

## FabriCounter Graphics Wrap

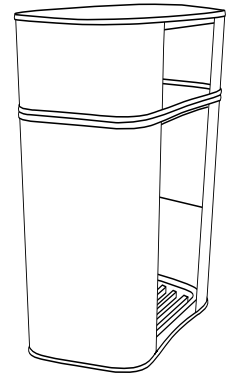

Front

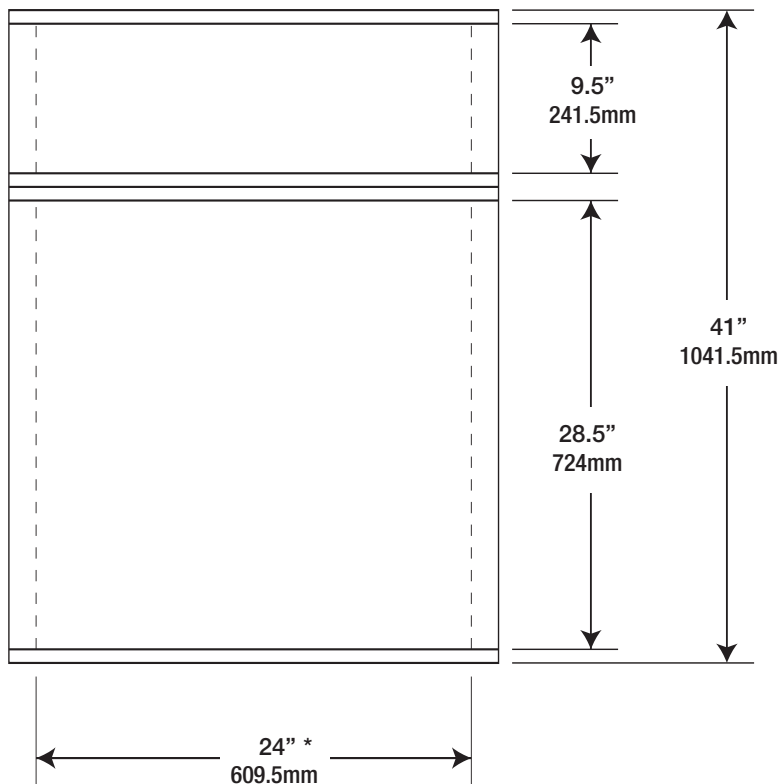

Top

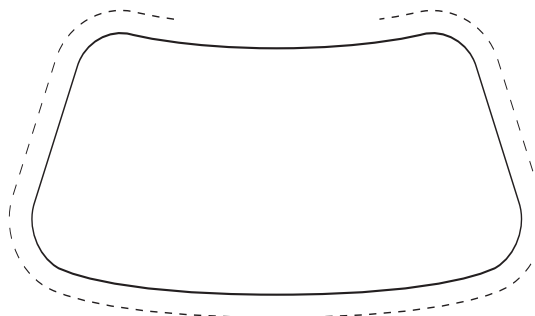

wraparound graphic  
header dimensions:  
width: 65" x height: 9.5"

**\* Note:**

Graphics designed to fit the front of the case and not wrap around the edges should be no larger than 24 inches wide.

## Rolluxe Counter

Graphics Conversion

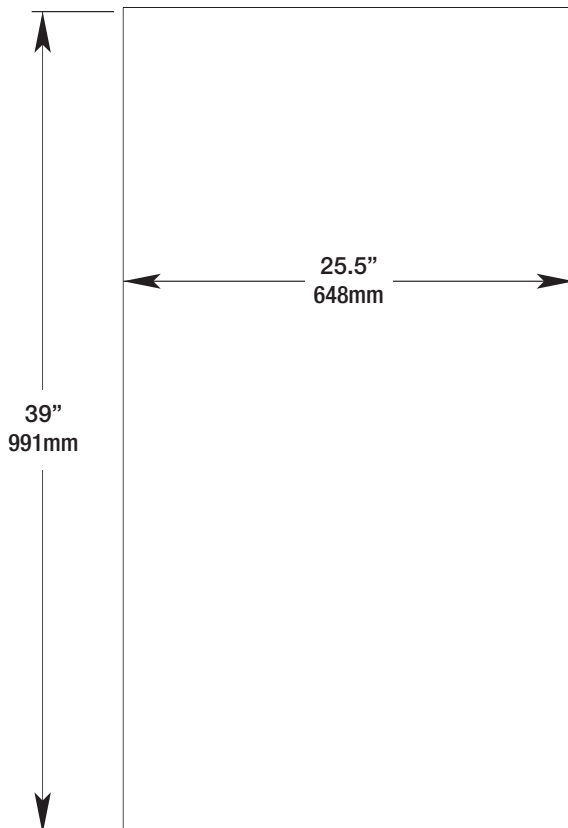
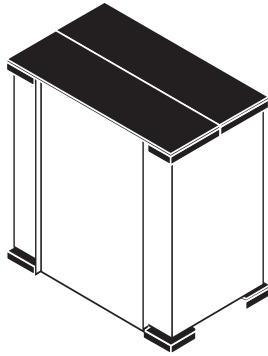

## Rolluxe Pedestal

Graphics Conversion

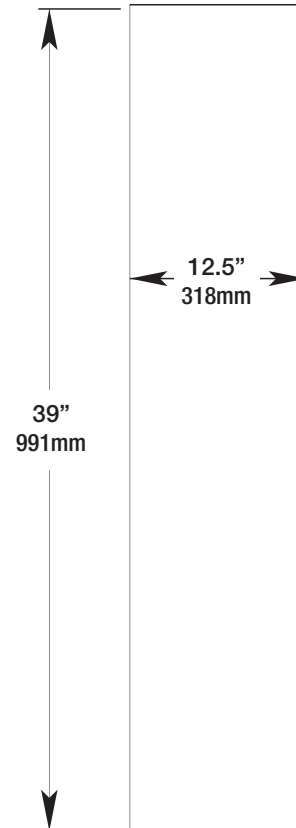
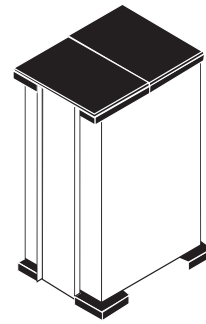



## Classic Counter Graphics Insert

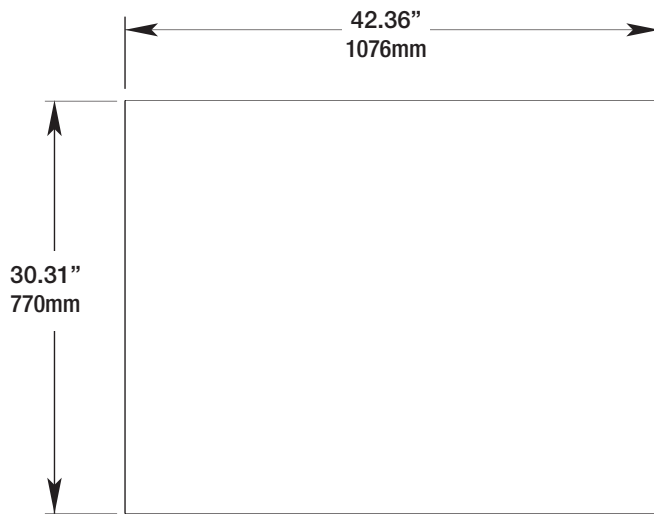
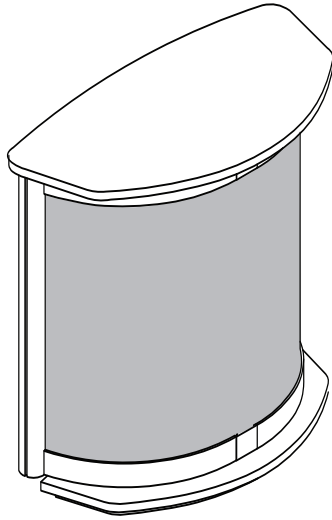

## Plus Counter Graphics Insert

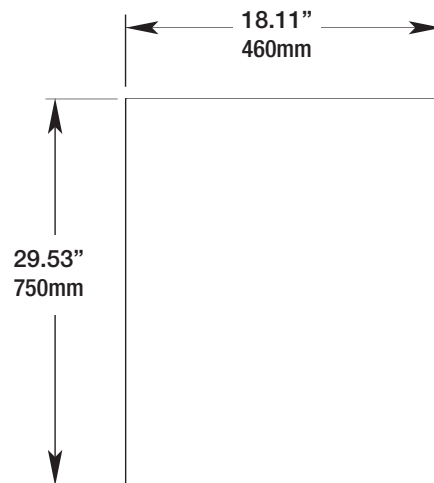
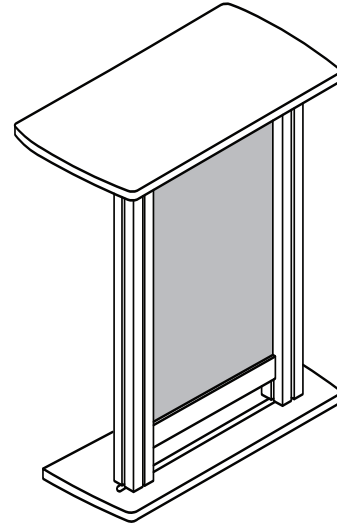

# Nomadic Display<sup>®</sup>

Misc Items  
Graphic Production Materials

## Instand (I)

| Code        | Qty. | Description  | Total Lbs. | Unit Price \$ | Total Price \$ |
|-------------|------|--|------------|---------------|----------------|
| GSCLB       | 1    | Classic Panel Bottom Stiffener   | 0.90       | 5             | 5              |
| GSCLBB      | 1    | Classic Back Panel Bottom Stiffener  | 3.80       | 5             | 5              |
| GSCLBR      | 1    | Reduced Quad Classic Panel Bottom Stiffener                                  | 0.00       | 5             | 5              |
| GSCLT       | 1    | Classic Panel Top Stiffener  | 0.90       | 5             | 5              |
| GSCLTB      | 1    | Classic Back Panel Top Stiffener   | 3.80       | 5             | 5              |
| GSCLTR      | 1    | Reduced Quad Classic Panel Top Stiffener                                     | 0.00       | 5             | 5              |
| GSPLB       | 1    | Plus Panel Bottom Stiffener  | 0.90       | 5             | 5              |
| GSPLT       | 1    | Plus Panel Top Stiffener   | 0.90       | 5             | 5              |
| GT3M36      | 1    | 180'/55m Roll of Double Sided Adhesive Tape (new)                            | 13.80      | 51            | 51             |
| GSHFB       | 1    | Hinged Filler Panel Bottom Stiffener   | 0.02       | 2             | 2              |
| GSHT        | 1    | Hinged Filler Panel Top Stiffener  | 0.02       | 2             | 2              |
| GSLFB       | 1    | Large Flat End Cap Bottom Stiffener  | 0.90       | 5             | 5              |
| GSLFT       | 1    | Large Flat End Cap Top Stiffener   | 0.90       | 5             | 5              |
| GSLRB       | 1    | Large Round End Cap Bottom Stiffener   | 0.90       | 5             | 5              |
| GSLRT       | 1    | Large Round End Cap Top Stiffener  | 0.90       | 5             | 5              |
| GSSFB       | 1    | Small Flat End Cap Bottom Stiffener  | 0.90       | 5             | 5              |
| GSSFT       | 1    | Small Flat End Cap Top Stiffener   | 0.90       | 5             | 5              |
| GSSRB       | 1    | Small Round End Cap Bottom Stiffener   | 0.90       | 5             | 5              |
| GSSRT       | 1    | Small Round End Cap Top Stiffener  | 0.90       | 5             | 5              |
| GEPSM3      | 1    | Three Quad High Plus Large Round PVC End Cap with Stiffener                  | 2.50       | 154           | 154            |
| GESSM3      | 1    | Three Quad High Small Round Lexan End Cap with Stiffeners an                 | 2.00       | 135           | 135            |
| GSAT        | 1    | Plus Panel 27 5/16/693.5mm Aluminum Stiffeners Bar with Adhesive Tape        | 1.24       | 5             | 5              |
| GSATLF      | 1    | Large Flat End Cap Aluminum Stiffener Bar with Adhesive Tape                 | 1.24       | 5             | 5              |
| GTDS180     | 1    | 180'/55m Roll of Double Sided Adhesive Tape                                  | 13.80      | 51            | 51             |
| GLHL        | 1    | Headliner Lexan Panel (14.5/368mm H x 10'/3m W x 25mil)                      | 6.00       | 51            | 51             |
| GTF         | 1    | 100'/30m Roll of B Foam Backed Magnetic Tape                                 | 12.00      | 51            | 51             |
| GTFA        | 1    | 100'/30m Roll of A Foam Backed Magnetic Tape                                 | 0.00       | 31            | 31             |
| GTMA100     | 1    | 100'/30m Roll of A Magnetic Tape   | 5.00       | 31            | 31             |
| GTMB100     | 1    | 100'/30m Roll of 1/2/12mm B Magnetic Tape                                    | 9.00       | 31            | 31             |
| GTVH150     | 1    | 300'/46m Roll of 1/2/3mm Velcro Hook Tape                                    | 2.30       | 205           | 205            |
| GTVH300     | 1    | 300'/92m Roll of 1/4/6mm Velcro Hook Tape                                    | 2.30       | 205           | 205            |
| YGSSRRT     | 1    | Reduced Qaud Small Round End Cap Top Stiffener                               | 0.5        | 5             | 5              |
| YGSSRRB     | 1    | Reduced Quad Small Round End Cap Bottom Stiffener                            | 0.5        | 5             | 5              |
| YGESDT      | 1    | Dual End Cap Top Stiffener   | 1.05       | 5             | 5              |
| YGESDB      | 1    | Dual End Cap Bottom Stiffener  | 1.05       | 5             | 5              |
| YGSTT       | 1    | Trapezoidal End Cap Top Stiffener  | 1.30       | 5             | 5              |
| YGSTB       | 1    | Trapezoidal End Cap Bottom Stiffener   | 0.80       | 5             | 5              |
| YGSPSHRT    | 1    | Right or Left Single Hinged or Medium Double Hinged Top Stiffener            | 0.9        | 5             | 5              |
| YGSPSHRB    | 1    | Right or Left Single Hinged or Medium Double Hinged Bottom Stiffener         | 0.9        | 5             | 5              |
| YGSPCST     | 1    | Small Connecting Plus Panel Top Stiffener                                    | 0.80       | 5             | 5              |
| YGSPCSB     | 1    | Small Connecting Plus Panel Bottom Stiffener                                 | 0.80       | 5             | 5              |
| YGSBPHT     | 1    | Custom Hinged Bubble Panel Top Stiffener - 889mm Wide                        | 3.80       | 21            | 21             |
| YGSBPHB     | 1    | Custom Hinged Bubble Panel Bottom Stiffener - 889mm Wide                     | 3.80       | 21            | 21             |
| YGEU3CST-01 | 1    | Three Quad high large flat rectangular tower fabric end cap top stiffener    | 0.90       | 5             | 5              |
| YGEU3CSB-01 | 1    | Three Quad high large flat rectangular tower fabric end cap bottom stiffener | 0.90       | 5             | 5              |
| YGSIT       | 1    | In Cap Top Stiffener   | 0.90       | 5             | 5              |
| YGSIB       | 1    | In Cap Bottom Stiffener  | 0.90       | 5             | 5              |

# Nomadic Instand<sup>®</sup>

**Misc Items**  
**Graphic Production Materials**

## Traveler (T)

| <b>Code</b> | <b>Qty.</b> | <b>Description</b>                   | <b>Total<br/>Lbs.</b> | <b>Unit<br/>Price \$</b> | <b>Total<br/>Price \$</b> |
|-------------|-------------|--------------------------------------|-----------------------|--------------------------|---------------------------|
| GSCLB       | 1           | Classic Panel Bottom Stiffener       | 0.90                  | 5                        | 5                         |
| GSCLT       | 1           | Classic Panel Top Stiffener          | 0.90                  | 5                        | 5                         |
| GSLRB       | 1           | Large Round End Cap Bottom Stiffener | 0.90                  | 5                        | 5                         |
| GSLRT       | 1           | Large Round End Cap Top Stiffener    | 0.90                  | 5                        | 5                         |

## Ideal (I)

| <b>Code</b> | <b>Qty.</b> | <b>Description</b>                                | <b>Total<br/>Lbs.</b> | <b>Unit<br/>Price \$</b> | <b>Total<br/>Price \$</b> |
|-------------|-------------|---|-----------------------|--------------------------|---------------------------|
| GSCLB       | 1           | Classic Panel Bottom Stiffener                    | 0.90                  | 5                        | 5                         |
| GSCLT       | 1           | Classic Panel Top Stiffener                       | 0.90                  | 5                        | 5                         |
| GSCLTB      | 1           | Classic Back Panel Top Stiffener                  | 3.8                   | 5                        | 5                         |
| GSCLTR      | 1           | Reduced Quad Classic Panel Top Stiffener          | 2.2                   | 5                        | 5                         |
| YGSSRRT     | 1           | Reduced Qaud Small Round End Cap Top Stiffener    | 0.5                   | 5                        | 5                         |
| YGSSRRB     | 1           | Reduced Quad Small Round End Cap Bottom Stiffener | 0.5                   | 5                        | 5                         |

**Aliasing**

The stair-stepped pattern in a bitmap image when the resolution is too low for the size of the output; also called “jaggies”.

**Anti-aliasing**

The smoothing of the rough edge pattern by averaging and blending of the boundaries and increasing the resolution.

**Banding**

Break up of graduated colours into larger blocks (bands) of single colour instead of a smooth transition; caused by insufficient colour ranges (less than 24-bit colour).

**Bleeding**

Spreading of ink into the paper or on the surface causing diffusion of the surroundings of shapes and indistinct edges.

**Bubble Jet**

Thermal inkjet printing systems associated with low cost desktop printers. The term is also used by Canon to describe thermal inkjet.

**Calibration**

Optimising settings for a printer/ink/media combination to known specifications in order to achieve accurate and consistent reproduction of the final print.

**CMYK**

Subtractive colour coding system used in inkjet printers for combining primary colours (Cyan, Magenta, Yellow and Black) to produce a full colour image.

**Coating**

Inkjet receptive layer on a film or paper that fixes inks.

**Cockle**

Puckering or warping of an image after printing due to uneven surface, excessive humidity or oversaturation of ink.

**Cold Lamination**

Application of a clear self-adhesive film (PVC or polyester) to protect a print or other substrate; may contain UV-filters; uses pressure sensitive adhesives. Cold lamination is appropriate when heat would adversely affect the substrate. The surface finish of the lamination film will determine the appearance of the print: gloss film for crisp colours, satin for a silky shine, matt for nonreflective applications. Prints must be completely dry before lamination to avoid bubbles due to trapped moisture.

**Colorimeter**

Optical device that measures colour values of reflected or emitted light by filtering into red, green and blue.

**Colour Management**

Coordination and control of colour representation in a chain of input, display and output devices.

**Colour Profile**

See ICC Profile.

**Continuous Inkjet**

Process where ink is forced through a printing nozzle at a steady flow. The droplets are electrically charged and either directed onto a substrate or deflected away into a collection system.

**Contour Cutting**

Cutting around outlines of a printed image on a self-adhesive media with a printer capable of “print-and-cut”.

**Contrast**

A measure of the ratio of brightness between the lightest and the darkest areas in an image.

**Cropping**

A process whereby a portion of an image is removed, usually from the outside of the image, to eliminate unwanted areas

**Cyan**

The “blue” colour in 4-colour CMYK printing; commonly know as process cyan

### **Dithering**

Method for simulating shades of grey of colour by only limited number and by varying size and shape of pixels.

### **Digital Printer**

Any printer capable of transforming digital data files into material copies. The most common printing technologies are thermal inkjet, piezoelectric inkjet, thermal transfer, electrostatic, offset and laser.

### **Dot**

Smallest single ink mark or spot on the printing substrate.

### **DPI**

Dots per inch; measure to describe the resolution as the number of separate dots printed along one linear inch. Sometimes incorrectly used as the unit of the resolution of a digital picture (number of pixel per inch).

### **Driver**

Extension file of a computer system controlling an external device such as a printer.

### **Dye Inks**

Organic colorants in inks; dyes have the ability to completely dissolve in a liquid (as opposed to pigments which are insoluble); dyes are brighter and have a higher saturation but are less stable over time; mainly used for indoor applications.

### **Dye Sublimation**

Colour printing technology in which the images are printed in reverse on a carrier and then transferred to the final substrate; heat or pressure activated.

### **EPS**

Encapsulated Postscript; graphic file format that includes 2 images, a resolution independent description of the page layout and content, and a low resolution bitmap picture used to preview the high resolution image; developed by Adobe Systems.

### **Floor Graphics**

Digital images applied on floors protected by a tough grained laminate.

### **GCR**

Grey Component Replacement; colour separating process that replaces the black obtained through portions of cyan, magenta and yellow by true black; this achieves more economical ink consumption and avoids the risk of ink quantities not being absorbed by the substrate. In addition this allows to obtain a better neutralisation of the grey tones and achieve a higher Dmax.

### **GIF**

Graphic Interchange Format; a graphic file format that allows exchange of image files across platforms; developed by CompuServe.

### **Halftone**

Process using a series of dots of various sizes within a fixed grid to simulate shades of grade.

### **HSV**

Hue, Saturation and Value; a colour model in which colour is described in terms of chromatic colour, its intensity and its variation from light to dark.

### **Hue**

One of the components of colour represented by angle of a 360° colour wheel.

### **ICC**

International Colour Consortium; group of companies standardising the format for colour profiles and cross platform colour management systems; includes Adobe, Agfa, Apple Computer, Microsoft amongst others.

### **ICC Profile**

Colour profile conforming to ICC specifications.

### **Inch**

Unit of length, one twelfth of a foot; 1in = 2.54cm

### **Ink**

Ink is composed of a carrier (water or solvent), colorants (pigments or dyes) and a binder (to fix the inks); may also contain alcohols.

### **Inkjet**

Printing process where ink is projected as dots onto a substrate in a pattern to form an image. The most common technologies are thermal inkjet that heats ink in the printhead to the boiling point and piezo-electric inkjet that applies an electric charge to a piezo-crystal which in turn changes its shape and thus expels the ink through the nozzles.

### **Jagging**

See Aliasing

### **JPEG/JPG**

Joint Photographers Expert Group; graphic file format that compresses full colour bitmap graphics to obtain smaller files; the process loses some information and thus slightly degrades the image quality.

### **L\*a\*b\***

Colour based on values of light (L), red-green (a) and yellow-blue (b).

### **Laminate**

Thin clear (transparent) plastic film applied to a media (vinyl, paper etc.) providing protection against humidity, abrasion and other wear; also enhances existing colour, providing a gloss, satin or matt surface appearance.

### **Lamination**

Process of bonding a laminate to a substrate by application of pressure and/or heat for protection or appearance.

### **Large Format Printing**

Printing on sheets larger than A3 or on rolls from 36in (914mm) wide

### **Levels of Grey**

Number of shades of grey between white and black

### **LFP**

See Large Format Printing

### **Light Magenta/Light Cyan**

Modified forms of the corresponding primary colours; help to achieve a more subtle rendition of light tones and more natural looking continuous tone prints on 6 colour printers.

### **Luminosity**

Brightness of a single colour.

### **Magenta**

The purple-red colour in 4-colour CMYK printing; commonly called process magenta

### **Moiré**

Wavy pattern that occurs when colour separations are conflicting or overlapping.

### **Nozzle**

Tiny hole in the orifice plate of the print head from which the ink is expelled.

### **Opacity**

Percentage of resistance of light passing through a substrate; measurement for the capacity of underlying colours or images to show through a media.

### **Opaque**

Light blocking substrate; one side does not show through to the other.

### **Optical Resolution**

The maximum actual (true) resolution of a scanner without interpolation.

### **Pantone**

Colour matching system identifying over 3000 colours and part of numerous colour management systems; owned by Pantone Inc.

### **PDF**

Portable Document Format; graphic file format that allows distribution of unalterable documents with the original formatting including pictures and fonts across platforms; developed by Adobe Systems Inc.

### **Pigment Inks**

Colorants in inks; pigment particles in the liquid medium form a suspension and do not dissolve in a liquid (as opposed to dyes); pigments are more stable over time. Pigments are often based on naturally occurring (inorganic) minerals such as metal oxides or charcoal.

### **PPI**

Pixels per inch; number of pixels in a line of one inch; indicator for the resolution of an image; the higher the number the greater the resolution.

### **Primary Colours**

Set of basic colours that make up other colours; additive colours are red, green and blue, together they make up white light; subtractive colours are cyan, magenta and yellow, together they make up black; real black is often added in printing to obtain a richer black.

### **Printer-cutter**

Inkjet printer that also cuts contours. Roland and Summagraphics manufacture printer-cutters.

### **Print Head**

Component on inkjet printers that forms the ink droplets and drives them onto the substrate; comprises inkfeed, transducer (thermal or piezo) and nozzle. A printer can have 64 or 128 nozzles that can expel ink simultaneously. The major print head manufacturers are Brother, Epson, Spectra and Xaar.

### **Process Colours**

Ink colours that combine and thus can reproduce any other colour; normally cyan, magenta and yellow; black is often added to save consumption of the basic colors.

### **Profile**

Settings of a colour management system that contain the colour reproduction characteristics of each device (scanner, printer etc).

### **RGB**

Additive colour coding system used for digital images for display on a monitor for combining primary colours (red, green and blue) to produce a full colour range. Before printing these colours must first be translated into the CMYK system to maintain the colour replication of the printed image.

### **Saturation**

A measurement of the purity of a colour; the white content of a pure chromatic colour is 0%.

### **Scanner**

A device that captures a digital image of a real object or picture; from an analogue picture the scanner produces a digital file.

### **Scrim**

Loosely woven polyester fabric coated or laminated with soft PVC; can be opaque (frontlit) or translucent (backlit).

### **Spectrophotometer**

Device for measuring the relative intensities of the light and the colorimetric values of a digital print.

### **Substrate**

The material that the process is applied to. Also called target surface; in case of digital printing it is the media.

### **Subtractive Colours**

Cyan, Magenta and Yellow; transparent colours that are combined to reproduce all other colours; black is sometimes added to obtain true, "blacker" black. See CMYK and GCR.

### **Thermal Inkjet**

Printing process where ink is heated to boiling point and through expansion is then projected from the head onto the substrate. Thermal print heads are cheaper but need to be replaced more often than piezo heads. Canon, Encad and Hewlett-Packard are manufacturers of thermal inkjet printers.

### **TIFF**

Tagged Image File Format; image file format used for high-resolution bitmaps; usable across platforms; developed by Aldus (now belongs to Adobe Systems).

### **Translucent**

Diffuse transmission of light. No clear image contours can be seen.

### **UV Curing Inks**

Inks that cure and create a bond to the substrate through polymerisation effected by ultra-violet irradiation from lamps on either side of the printhead assembly; commonly found on flatbed printers.

### **UV Inks**

Inks containing pigments that resist fading under UV light and have longer outdoor durability.